

Experience Your **SMART FACTORY**

Machine Tool Products



CNC Swiss Turning Lathe
Centerless Grinding Machine

Enjoy Total Engineering Solution

After starting the machine tool business in 1977, Hanwha Precision Machinery has become a leading worldwide Smart Factory solutions provider, offering Surface Mount Technology (SMT) mounters, Machine Tool, Collaborative robots, industrial automation equipment, and integrated software solutions. We do this to develop customer-oriented solutions that deliver greater efficiency, versatility and value.

Machine Tool Division

CNC Swiss turning Lathe • Centerless Grinding Machine

Offers customized solutions with a wide range of line-up for automatic lathes in gang & turret type and centerless grinding machines.



Surface Mounter Technology Division

Chip Mounter • Screen Printer • Semiconductor Equipment

After developing its first chip mounter, offers SMT mounters, semiconductor equipment, industrial automation equipment and software solutions.



Collaborative Robot Division

HCR-3 • HCR-5 • HCR-12 Robot

Offers the collaborative robot HCR series for more convenient and safer future.



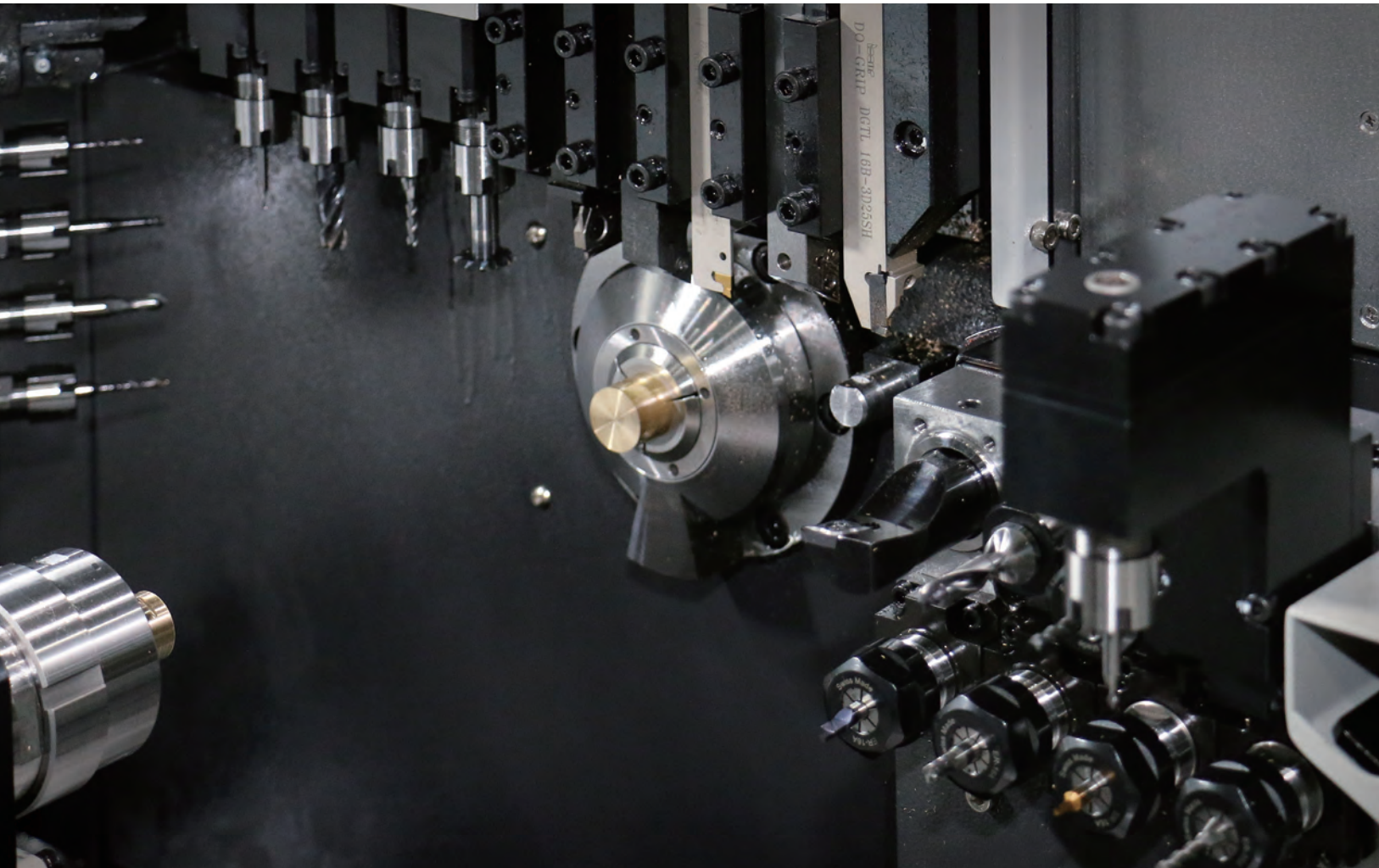

Hanwha Precision Machinery

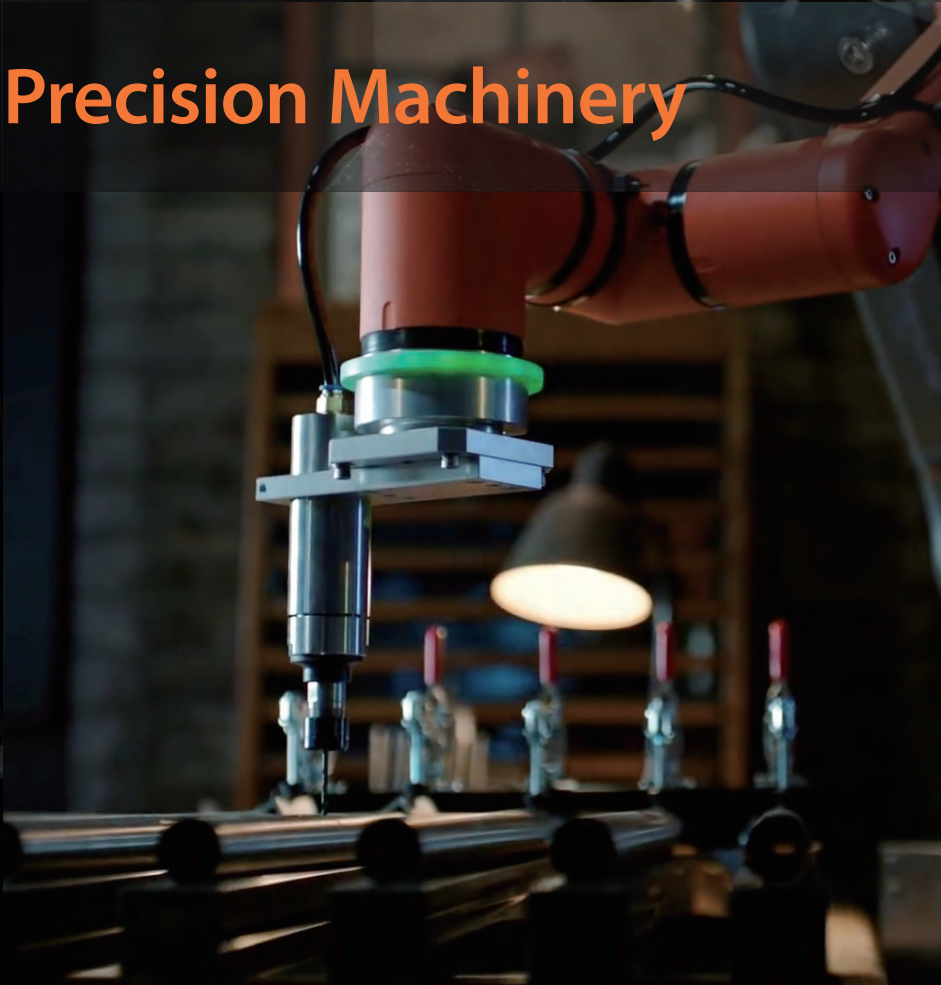
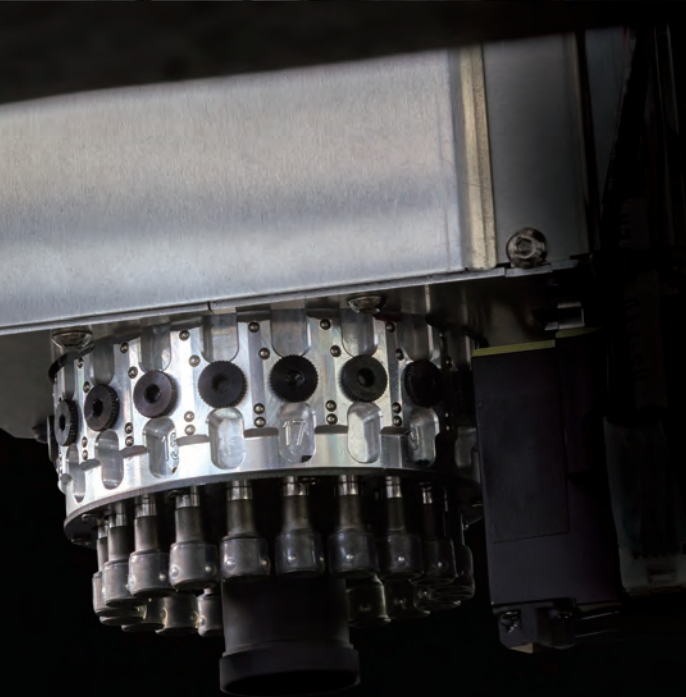

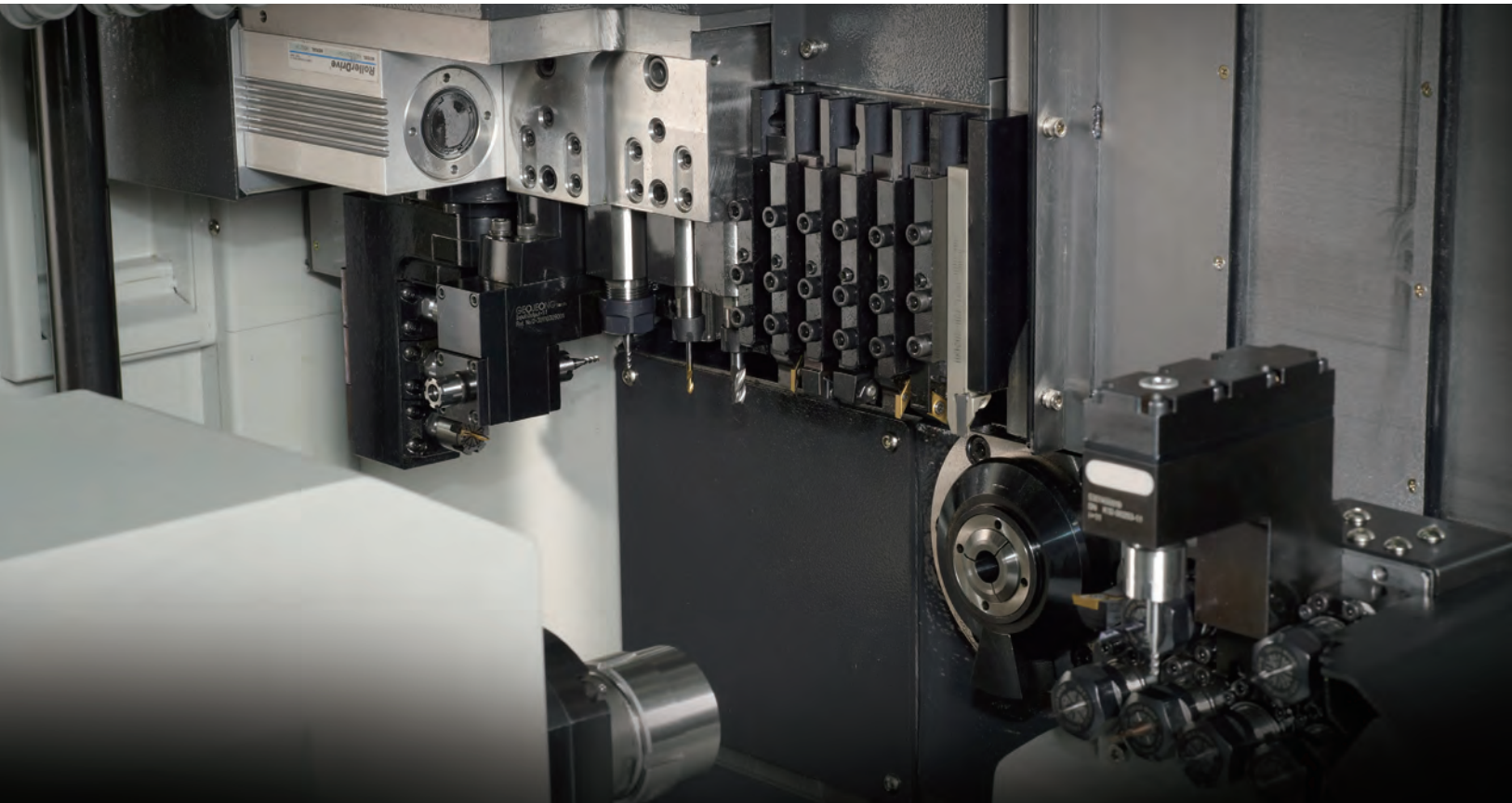

CNC Swiss Turning Lathe

Provides the best customized machining solution with a wide range of line-up from Ø3mm to Ø42mm and various options



Centerless Grinding Machine

Develops and produces KCG and HCG series of centerless grinding machine with high precision & rigidity

Machine Tool Division

Turning forward to the Future

Starting the machine tool business 1977 and developing its first CNC Swiss turning machine in 1998, Hanwha machine tool division has been focusing on product development to best fit customer's various needs and resulted in a wide range of line-up of excellent gang & turret type series. We, as a leading Swiss turning solution provider, will continue to strive to reach the top position in the machine tool business, accelerating our innovation and growth based on our +50 years of business experience and ever-expanding Hanwha global network.

To be the Global
No.

Exports to more than
30 countries in the world

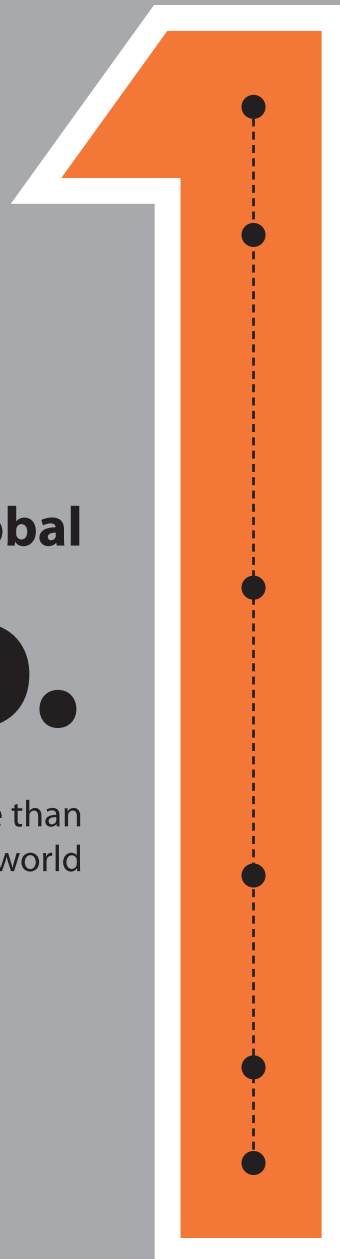

2020

Developed high-complex turret type, STL42
Developed high-productive model, XD10

2010

2019 Developed XD38II-R, heavy duty cutting model
Established Europe technical center in Germany
2018 Developed Hi-CPS, Smart Factory MES system
Developed XD20/26II-V, high complex model
2016 Developed upgraded line-up; XD-II, XE series
Developed XD12/16III, XD42
2014 Established Hanwha machinery Suzhou in China
Opened Stuttgart office in Germany
2010 Developed XD07, compact and precise machine

2000

2008 Opened Milwaukee office in U.S.A
2006 Developed XD20N, the first non-guide bush type CNC automatic lathe in Korea
Developed XD32/35 series
2005 Developed XP series, 4-axis CNC automatic lathe
2004 Opened Suzhou office in China
Developed XD20H, CNC automatic lathe

1990

1998 Developed ML series, the first CNC automatic lathe in Korea
1994 Developed Centerless grinding machine KCG-200J
1992 Developed the first internal grinding machine

1983

Developed SAL-10, the first cam type lathe in Korea

1977

Started machine tool business

Platforms

Hanwha CNC Swiss turning machines with a full line-up ranging from 3 to 42 mm, featured with high-grade CNC unit, complex tooling and high-rigidity machine structure can achieve high complex and precision machining. The Hanwha sliding headstock machines offer various range of models with optimized design combination as per customer's requirement.

CNC Swiss Turning Lathe

XP Series

Budget-friendly 4-axis entry models

- CNC unit : Hanwha Fanuc-i
- Ø12, 16, 20, 26, 32
- High-productivity machining for simple workpiece

08 **XP12/16S**

09 **XP20/26/32S**



XE Series

Value for money 5-axis models

- CNC unit : Hanwha Fanuc-i
- Ø20, 26, 35
- Affordability with stable and high productivity

10 **XE20/26**

11 **XE35**



XD Series

Flagship multi-axis models for high precision & complex machining

- CNC unit : Hanwha Fanuc-i, 32i-B
Siemens 828D, 840D
- Ø03, 07, 12, 16, 20, 26, 32, 38, 42

12 **XD03/07**

13 **XD12/16III**

14 **XD20/26II (F, S)**

16 **XD20/26II-V (F, S)**



34 Special Functions

Hi-CPS

Hanwha Smart Factory Solution

PCR / PCRS & Oscillation

Chip breaking solution

Customer & Performance Supporting Function

Centerless Grinding Machine

STL Series

3-path controlled, powerful turret type models

- Covering almost entire range of material size
- Equipped with high-end CNC for high precision
- Specially structured for high rigidity and stability

18 **XD32/38II**

20 **XD38II-R (F, S)**

22 **XD42**

- CNC unit : Siemens 840D
- Ø32, 38, 42
- Synchronous machining & 3 path control system
- Ultimate tooling capability with 10 station turret (VDI30 & BMT45)

24 **STL32/38 (S)**

26 **STL42 (S)**

KCG Series

Single grip spindle for easy replacement

30 **KCG**

KCG-150CNC, KCG-200J,
KCG-200/300 (CNC)

HCG Series

High precision & rigidity centerless grinding machine with twin grip G/W and R/W spindle

※ HCG-150CNC : Single grip G/W spindle

31 **HCG**

HCG-150CNC, HCG-300 (CNC),
HCG-400 (CNC)



XP12/16S

Compact, in-budget 4-axis model for max. dia. 12/16mm

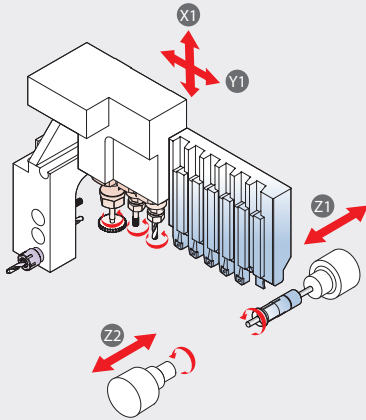

OPTION
 • Cross 4
 • Gear hobbing unit



OPTION TOOLING

Cross unit 4

- OD 5 (□12),
- Cross 4 (ER16x1, ER11x3),
- Front 3 (ER11)



Gear hobbing unit

- Maker : Pibomulti
- Angle : -2° ~ 2°

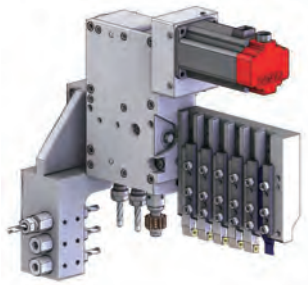

Model	XP12S	XP16S
NC	Hanwha Fanuc-i	
Max. machining diameter	Ø12	Ø16
Z1 Stroke (mm)	140	
Main spindle	rpm	12,000
	kW	2.2/5.5
OD tool	No. of tools 6 (□12mm)	
Front tool	No. of tools 3 (ER11, Ø20)	
Cross drill	No. of tools 3 (ER11 x 2, ER16 x 1)	
	rpm	6,000
	kW	0.5
Sub spindle	rpm	8,000
	kW	0.55/1.1
Machine size (L x W x H) (mm)	1,650 x 1,090 x 1,640	
Weight (kg)	1,800	
Power Consumption (Cable size)	10kVA, 6.7kW (VCTF 10SQ x 4C)	
Air Flow rate (Liter/Min)	120 ~ 150	

Dimension

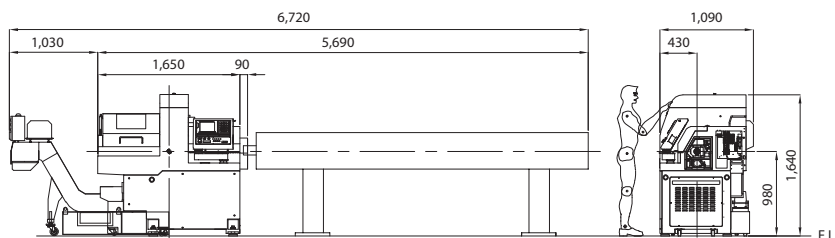

XP20/26/32S

Compact, in-budget 4-axis model for max. dia. 20/26/32mm
(with side cross tool)

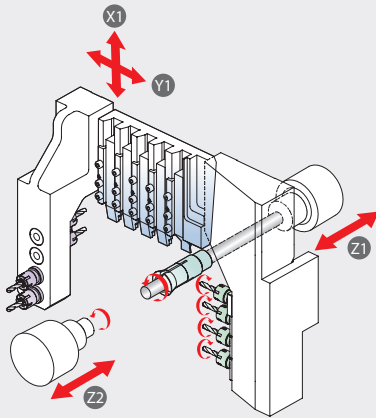

OPTION TOOLING

Cross unit 4 (1 modular)

- ER16M x 4

※ Standard cross : Non-modular

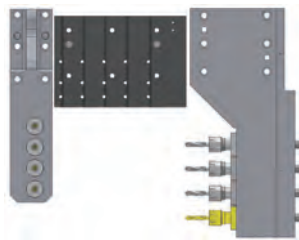

- Right choice for old cam lathe users who need better precision and productivity
- Steady selling model with proven performance & quality

Model	XP20S	XP26S	XP32S	
NC	Hanwha Fanuc-i			
Max. machining diameter	Ø20	Ø26	Ø32	
Z1 Stroke (mm)	210	205		
Main spindle	rpm	8,000		
	kW	2.2/3.7	5.5/7.5	
OD tool	No. of tools	6 (□12mm)	5 (□16mm)	
	Front tool	4 (ER16M, Ø25)		
Cross drill	No. of tools	4 (ER16M)		
	rpm	6,000	5,000	
	kW	1.0		
Sub spindle	rpm	8,000		
	kW	0.55/1.1	1.5/2.2	
Machine size (L x W x H) (mm)	2,030 x 1,140 x 1,710			
Weight (kg)	2,300	2,500		
Power Consumption (Cable size)	XP20S : 10kVA, 6.7kW (VCTF 10SQ x 4C) XP26/32S : 15kVA, 10kW (VCTF 16SQ x 4C)			
Air Flow rate (Liter/Min)	120 ~ 150			

Dimension

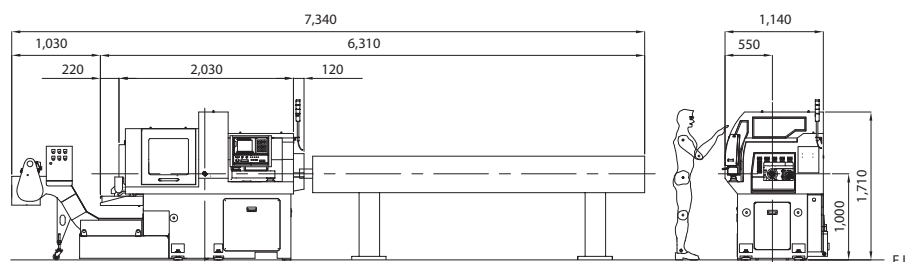

XE20/26

5-axis model with reliable performance for max. dia. 20/26mm

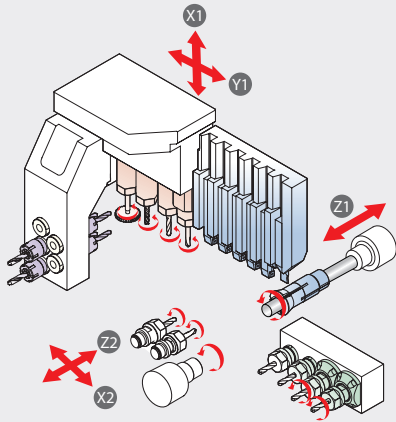

OPTION

- Off-center drill (Driven, Fixed) 2
- Cross 5 ~ 6



OPTION TOOLING

Cross unit 5

- OD 5 (□16),
- Cross 5 (ER16M),
- Front 3 (ER16M)

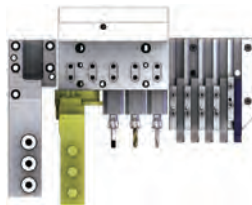

Cross unit 6

- OD 6 (□16x1 + □11x5),
- Cross 6 (ER11Mx2, ER16x4)



※ Option : 3 Face/counterface driven tool,
3 Face/counterface angle driven tool

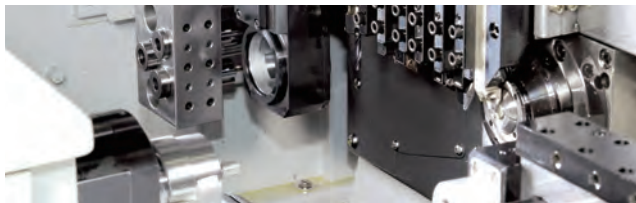

Model		XE20/26				
		H	N	NH	J	Ne
NC		Hanwha Fanuc-i				
Max. machining diameter		Ø20/26				
Z1 Stroke (mm)		210	60	160 (H), 50 (N)	210	60
Main spindle	rpm	10,000 (Ø20), 8,000 (Ø26)				
	kW	2.2/3.7 (Ø20), 2.2/5.5 (Ø26)				
OD tool	No. of tools	6 (□12mm) (Ø20), 5 (□16mm) (Ø26)				
Front tool	No. of tools	5 (ER16M, Ø25)				
Cross drill	No. of tools	4 (ER16)				
	rpm	6,000				
	kW	1.0				
Off-center drill (Option)	No. of tools	2 (ER16)				
Sub spindle	rpm	8,000				
	kW	1.5/2.2				
Back tool	No. of tools	4 (ER16) (2 Fixed + 2 Driven)		4 (ER16) (4 Fixed)		
	rpm	6,000				
	kW	1.0				
Machine size (L x W x H) (mm)		2,260 x 1,240 x 1,670				
Weight (kg)		2,500				
Power Consumption (Cable size)		15kVA, 10kW (VCTF 105Q x 4C)				
Air Flow rate (Liter/Min)		120 ~ 150				

* H : G/B & Driven back tool(2), J : G/B & Fixed back tool

* N : Non-G/B & Driven back tool(2), Ne : Non-G/B & Fixed back tool, NH : Convertible G/B & Driven back tool(2)

Dimension

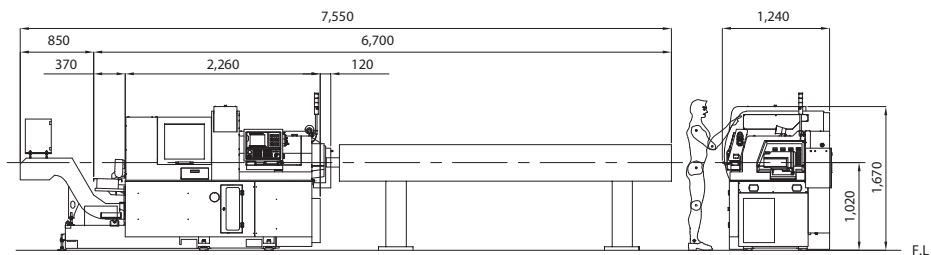

XE35

5-axis model with reliable performance for
max. dia. 35mm

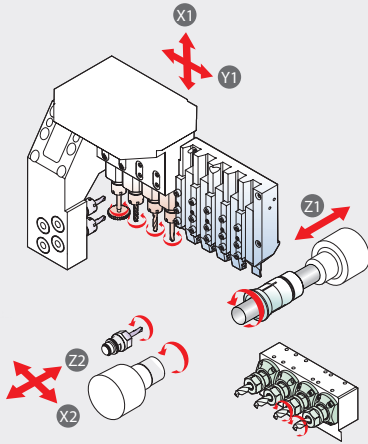

OPTION

- Off-center drill (Driven) 1
- Cross 5



OPTION TOOLING

Cross unit 5

- OD 5 (□12),
- Cross 5 (ER16M),
- Front 5 (ER16M)

- ※ Cross(standard): Spline modular type
- ※ Option : 3 Face/counterface driven tool,
3 Face/counterface angle driven tool

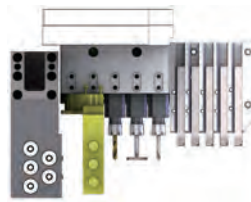

Model	XE35			
	H	N	J	Ne
NC	Hanwha Fanuc-i			
Max. machining diameter	Ø35			
Z1 Stroke (mm)	210	60	210	60
Main spindle	rpm	6,500		
	kW	2.2/5.5		
OD tool	No. of tools	5 (□16mm)		
Front tool	No. of tools	4 (ER16M, Ø25)		
Cross drill	No. of tools	4 (ER16M)		
	rpm	6,000		
	kW	1.0		
Off-center drill (Option)	No. of tools	1 (ER16)		
Sub spindle	rpm	6,500		
	kW	1.5/2.2		
Back tool	No. of tools	4 (ER16) (2 Fixed + 2 Driven)	4 (ER16) (4 Fixed)	
	rpm	6,000	-	
	kW	1.0	-	
Machine size (L x W x H) (mm)	2,050 x 1,490 x 1,760			
Weight (kg)	2,750			
Power Consumption (Cable size)	15kVA, 10kW (VCTF 105Q x 4C)			
Air Flow rate (Liter/Min)	120 ~ 150			

* H : G/B & Driven back tool(2), J : G/B & Fixed back tool

* N : Non-G/B & Driven back tool(2), Ne : Non-G/B & Fixed back tool

Dimension

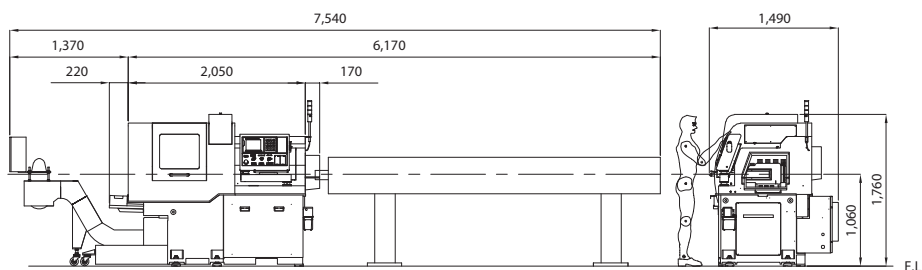

XD03/07

High-performing 4-axis for small precision parts
(Max. dia. 7mm)

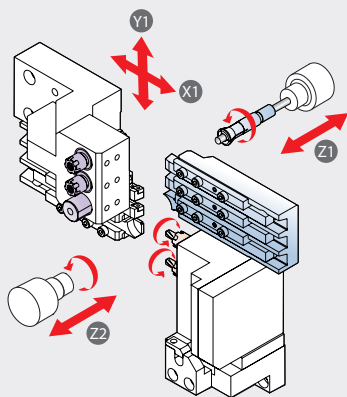

OPTION TOOLING

Cross unit 2

- Front 3, Cross 2, OD 6

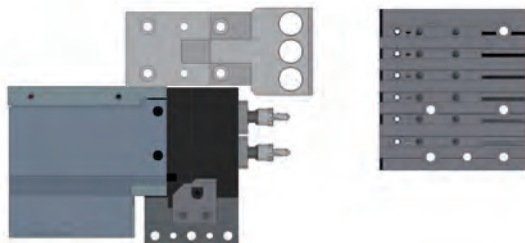

Cross unit 3

- Front 3, OD 4(3+1), Cross 3

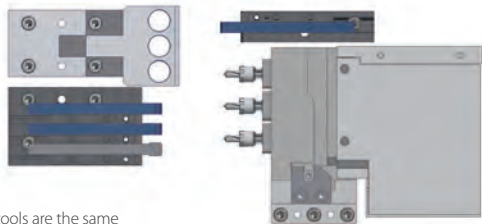

※ Spec of tools are the same

Model	XD03/07	
NC	Hanwha Fanuc-i	
Max. machining diameter	Ø3/7	
Z1 Stroke (mm)	125	
Main spindle	rpm	16,000 (Rotary G/B 10,000 rpm)
	kW	1.1/1.5
OD tool	No. of tools	6 (□8mm) (3 + 3)
	No. of tools	3 (ER8M, Ø15.875)
Cross drill	No. of tools	2 (ER8M)
	rpm	9,000
	kW	0.35
Sub spindle	rpm	16,000
	kW	1.1/1.5
Machine size (L x W x H) (mm)	1,330 x 750 x 1,450	
Weight (kg)	1,000	
Power Consumption (Cable size)	8kVA, 5.4kW (VCTF 6SQ x 4C)	
Air Flow rate (Liter/Min)	120 ~ 150	

OPTION UNIT

Special G/B units to enhance machining precision for small material under Ø7mm



Rotary G/B



Stationary G/B with fine-adjustment

Dimension

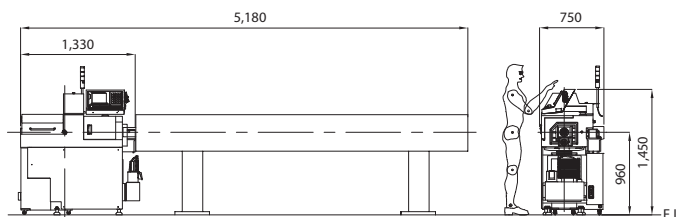

XD12/16III

High-speed 5-axis solution for max. dia. 12/16mm

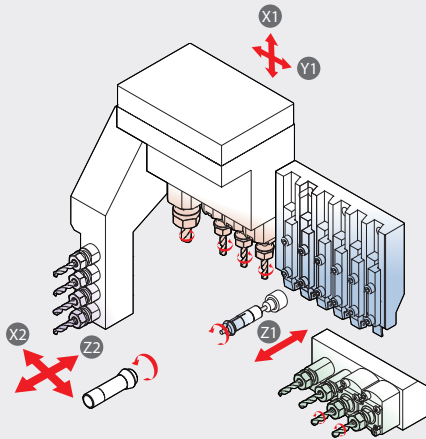

OPTION

- Long drill (Fixed) 1
- Back tool 4 ~ 5

※ Cross(standard) : Non-modular type with single body



OPTION TOOLING

Cross unit 4 (modular 1)

- ER11x3, Modular ER16x1
- ※ Standard cross : Non-modular



Cross unit 5 (modular 2)

- ER11x3, Modular ER16x2



Option unit
Front tool unit attached
on cross body

- Fast cycle time
- High speed of spindle (Main : 15,000rpm, Sub : 10,000rpm)
- Great machining performance with strong motor power for back tool (Capacity : 1.0kW)

Model	XD12/16III	
	H	J
NC	Hanwha Fanuc-i	
Max. machining diameter	Ø12/16	
Z1 Stroke (mm)	155	
Main spindle	rpm	15,000
	kW	2.2/3.7
OD tool	No. of tools 5 (□12mm)	
Front tool	No. of tools 4 (ER11, Ø20)	
Cross drill	No. of tools	4 (ER11 x 3 + ER16 x 1)
	rpm	6,000 (ER11), 9,000 (ER16)
	kW	1.0
Long drill (Option)	No. of tools	1 (ER11) drilling depth : 76.5mm
Sub spindle	rpm	10,000
	kW	0.55/1.1
Back tool	No. of tools	4 (ER11) (2 Fixed + 2 Driven)
	rpm	9,000
	kW	1.0
Machine size (L x W x H) (mm)	1,700 x 1,190 x 1,670	
Weight (kg)	2,200	
Power Consumption (Cable size)	15kVA, 10kW (VCTF 10SQ x 4C)	
Air Flow rate (Liter/Min)	120 ~ 150	

* H : G/B & Driven back tool(2), J : G/B & Fixed back tool

Dimension

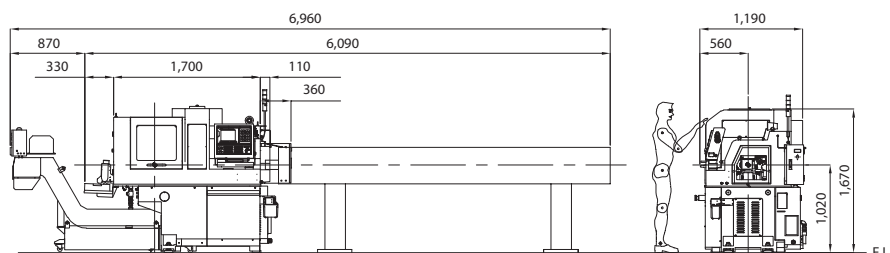

XD20/26II

The best selling 5-axis for max. dia. 20/26mm

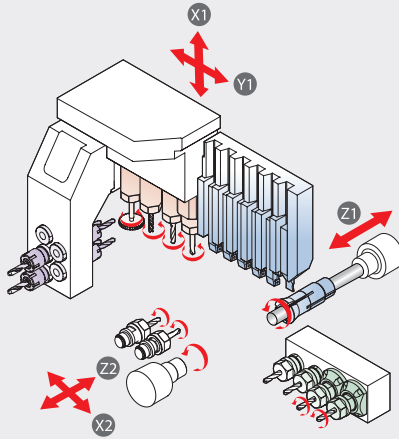

- OPTION**
- Off-center drill (Driven, Fixed) 2
 - Cross drill 5 ~ 6
 - Back tool 5 ~ 6

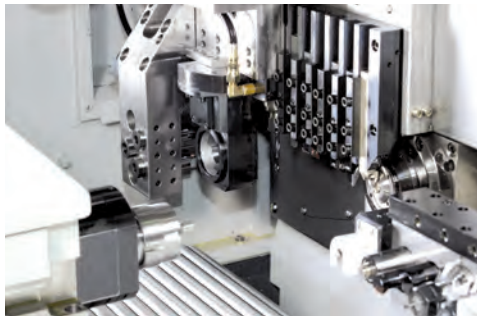

- Maximized tooling capability with a variety of customized options
- The best-suited for high precision and accuracy

Model		XD20/26II			
		H	N	NH	M
NC		Fanuc 32i-B / Siemens 828D			
Max. machining diameter		Ø20/Ø26			
Z1 Stroke (mm)		210 (Fanuc), 240 (Siemens)	60mm	160 (H), 50 (N)	210
Main spindle	rpm	10,000 (Ø20), 8,000 (Ø26)			
	kW	Fanuc : 2.2/3.7 (Ø20), 2.2/5.5 (Ø26) Siemens : 14.4			
OD tool	No. of tools	6 (□12mm) (Ø20), 5 (□16mm) (Ø26)		5 (□12mm)	
Front tool	No. of tools	5 (ER16M, Ø25)			
Cross drill	No. of tools	4 (ER16 (Ø20), ER16M (Ø26))			5 (ER16M)
	rpm	6,000			
	kW	Fanuc : 1.0, Siemens : 1.02			
Off-center drill (Option)	No. of tools	2 (ER16) Driven		2 (ER16M) Fixed long drill	
	rpm	8,000			
Sub spindle	kW	Fanuc : 1.5/2.2, Siemens : 2.59			
	No. of tools	4 (ER16) (2 Fixed + 2 Driven)			
Back tool	rpm	6,000			
	kW	Fanuc : 1.0, Siemens : 1.02			
	Machine size (L x W x H) (mm)	2,260 x 1,230 x 1,710			
Weight (kg)		2,700			
Power Consumption (Cable size)		15kVA, 10kW (VCTF 10SQ x 4C)			
Air Flow rate (Liter/Min)		120 ~ 150			

* H : G/B, N : Non-G/B, NH : Convertible G/B, M : Cross 5-axis+Long drills

Dimension

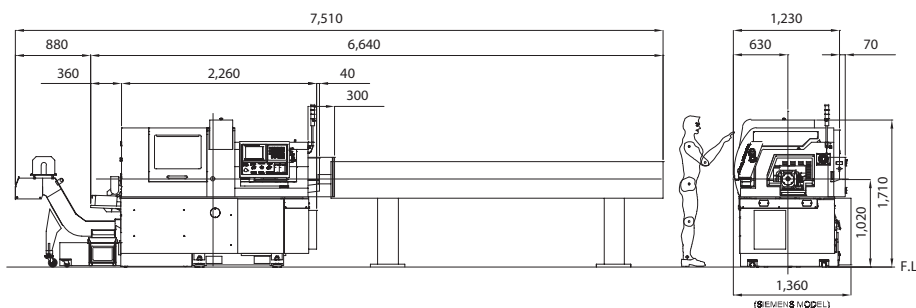

Option Tooling

Offers various and flexible toolings for enhancing productivity and covering a variety of customer's needs

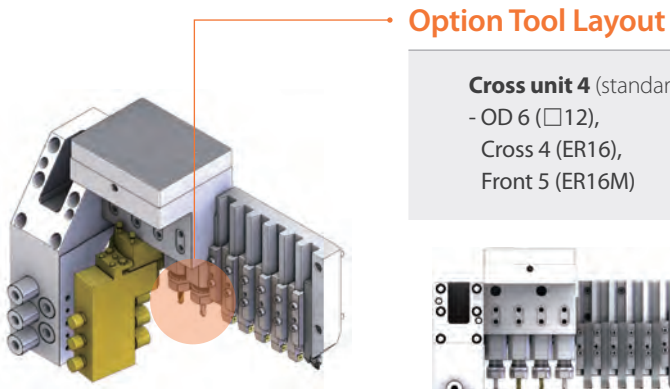

Option Tool Layout

Cross unit 4 (standard)

- OD 6 (□12),
Cross 4 (ER16),
Front 5 (ER16M)

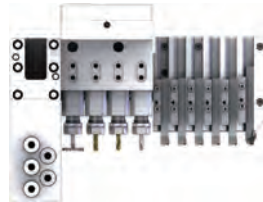

Cross unit 5

- OD 5 (□16),
Cross 5 (ER16M),
Front 3 (ER16M)

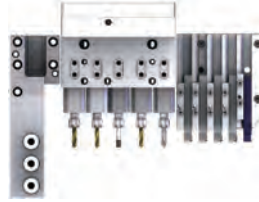

Cross unit 6

- OD 6 (□16 x 1, □11 x 5),
Cross 6 (ER11M x 2, ER16 x 4)

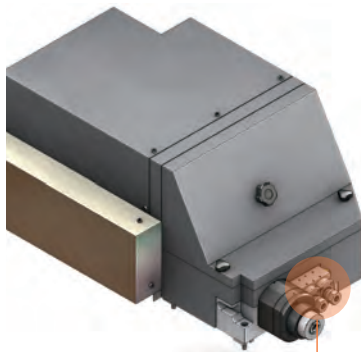
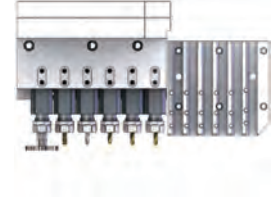

Off-Center Unit

- Sub spindle unit provides 2 driven drills or 2 fixed long drills for deep hole machining (option)

Option tool



Long drill

Internal coolant driven tool

Tailstock

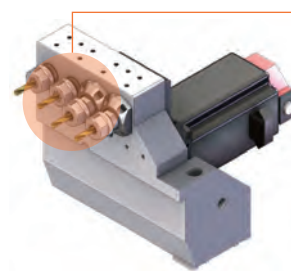

Back Tool Unit

- A total of 6 tools as an option and modular type for easy tool change / maintenance

Option unit



Attachable fixed drill unit

Option tool



Internal coolant driven tool

Back and cross tool

Burr removal tool

Selectable modules of back tool

Driven max. 4



4 tools

5 tools

6 tools

※ Unable to use Off-center for 5 ~ 6 tools

Standard

- Main-Sub Cs control (0.001°)
- Rotary Guide bush holder
- Cross drilling · milling unit (4, Gear modular type)
- MPG
- Part conveyor
- Door interlock
- Coolant flow sensor
- Work light
- Signal lamp (3color)
- LAN port
- Tool monitoring function
- Cut off tool breakage detector (S/W)
- Auto power off
- Bar feeder interface

Option

- Bar feeder
- Chip conveyor
- Transformer
- Tap breakage detector
- Pipe type ejection unit
- Off center drill unit (2)
- Middle / High pressure pump
- Oil mist collector
- Oil chiller
- Memory card
- Tooling & Programming
- Internal coolant driven tool (cross, back, off-center)
- 3 Face/counterface driven tool (cross)
- 3 Face/counterface angle driven tool (cross)
- Extended coolant tank
- NC warranty for 2 years

XD20/26II-V

Multi-functional with B and Y2-axis

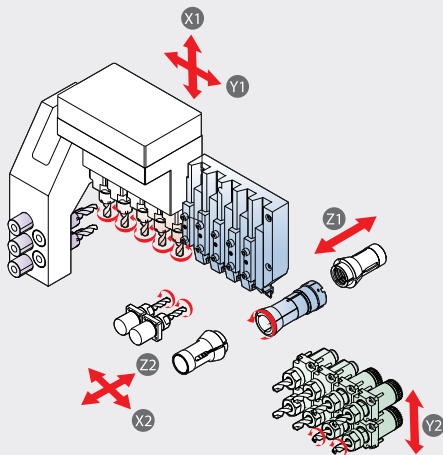

- OPTION**
- Off-center drill (Driven, Fixed) 2
 - B-axis tool post 8 (Front 4 + Back 4)
 - Y2 back tool cross unit (Max. Cross 2)

OPTION TOOLING

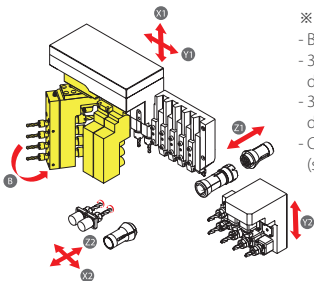

- ※ Option
- B-axis
 - 3 Face/counterface driven tool
 - 3 Face/counterface angle driven tool
 - Cross back tool unit (single body)

- Ultimate tooling capability adopting B-axis and Y2-axis
- Minimized thermal deformation with cooling system for Cross drilling/milling unit
- Adopted powerful built-in motor for main/sub spindle (2.2/3.7kW(Fanuc), 14.4kW(Siemens))

Model	XD20/26II-V		
	H	N	NH
NC	Fanuc 32i-B / Siemens 828D (B-axis 840D)		
Max. machining diameter	Ø20/26		
Z1 Stroke (mm)	210	50	210 (H), 50 (N)
Main spindle	rpm	10,000 (Ø20), 8,000 (Ø26)	
	kW	Fanuc : 2.2/3.7 (Ø20), 2.2/5.5 (Ø26) Siemens : 14.4	
OD tool	No. of tools	6 (□12mm) (Ø20), 5 (□16mm) (Ø26)	
Front tool	No. of tools	5 (ER16M, Ø25)	
Cross drill	No. of tools	5 (ER16 (Ø20), ER16M (Ø26))	
	rpm kW	6,000 1.0 (Fanuc), 1.02 (Siemens)	
Off-center drill (Option)	No. of tools	2 (ER16) Modular	
Sub spindle	rpm	8,000	
	kW	2.2/3.7 (Fanuc), 14.4 (Siemens)	
Back tool	No. of tools	8 (ER16) (4 Fixed + 4 Drvien)	
	rpm	6,000	
	kW	1.0 (Fanuc), 1.02 (Siemens)	
Machine size (L x W x H) (mm)	2,460 x 1,380 x 1,730		
Weight (kg)	2,900		
Power Consumption (Cable size)	15kVA, 10kW (VCTF 10SQ x 4C)		
Air Flow rate (Liter/Min)	120 ~ 150		

* H : G/B, N : Non-G/B, NH : Convertible G/B

Dimension

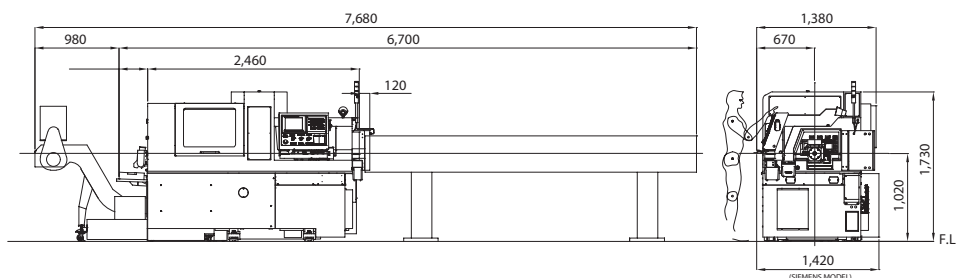

Option Tooling

Complex & productive machining for multi shape parts with B-axis cross and Y2-axis back tooling

Cross Drilling / Milling Unit

- Cross unit with gear modular type for various tooling and easy tool change / maintenance

※ Various option tool unit : Triple speed rotating drill, Internal coolant driven tool, 3 Face / counterface driven tool, 3 Face / counterface angle driven tool

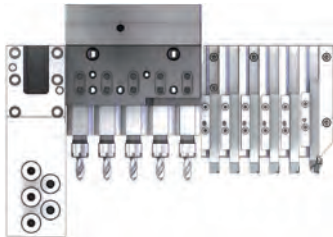

Cross unit 5
- OD 6 (□12),
Cross 5 (ER16),
Front 5 (ER16M)
※ for XD20II-V

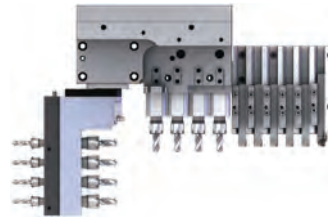

B-axis Cross unit
- OD 6 (□12),
Cross 4 (ER16),
B-axis 4 (ER16x4, ER11x4)
※ for XD20II-V

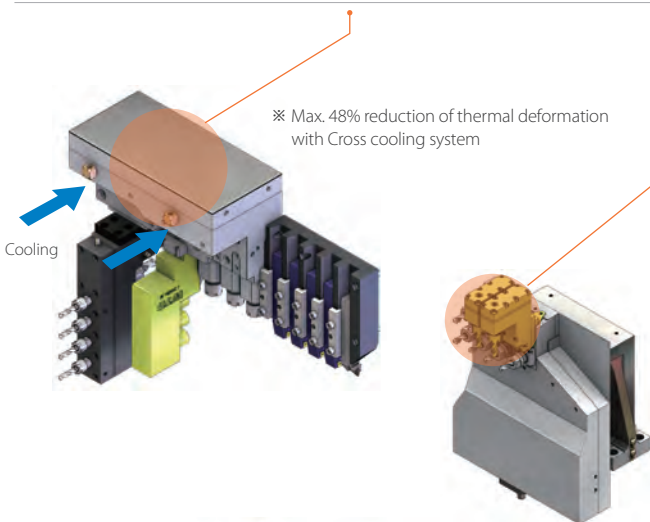

Back Tool Unit

- Y2-axis tool post offering flexible & various tooling on Back
- Stable machining with enhanced structure & powerful motor

Option tool



Internal coolant driven tool

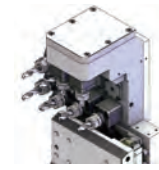

Back tool cross unit (Single body)



Back tool cross unit (Modular)

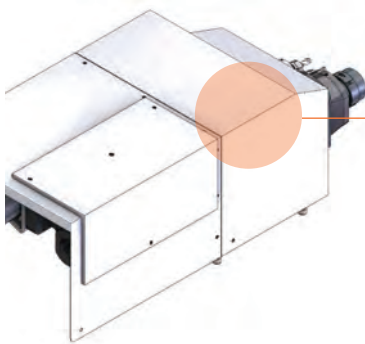

Sub Spindle & Off-Center Unit

- Adopted built-in motor to sub spindle for precision machining

※ Off-center drill (Driven, Fixed) 2 is available

	Feature	Value
Sub spindle unit	Max. machining diameter	Ø20/26 mm
	Rotation speed	8,000 rpm
	Motor	2.2/3.7 kW (Fanuc) 14/4 kW (Siemens)
Off-center drill unit (Option)	Drill	2 (ER16)
	Type	Gear modular

Standard

- Main · Sub Cs control (0.001°)
- Rotary Guide bush holder
- Cross drilling · milling unit (5, Gear modular type)
- MPG
- Part conveyor
- Door interlock
- Coolant flow sensor
- Work light
- Signal lamp (3color)
- LAN port
- Tool monitoring function
- Cut off tool breakage detector (S/W)
- Auto power off
- Bar feeder interface

Option

- Bar feeder
- Chip conveyor
- Transformer
- Tap breakage detector
- Pipe type ejection unit
- Off center drill unit (2)
- Middle / High pressure pump
- Oil mist collector
- Oil chiller
- Memory card
- Tooling & Programming
- Internal coolant driven tool (cross, back, off-center)
- 3 Face/counterface driven tool (cross)
- 3 Face/counterface angle driven tool (cross)
- Extended coolant tank
- NC warranty for 2 years

XD32/38II

Specialized 5/6/7-axis model for heavy duty cutting / milling

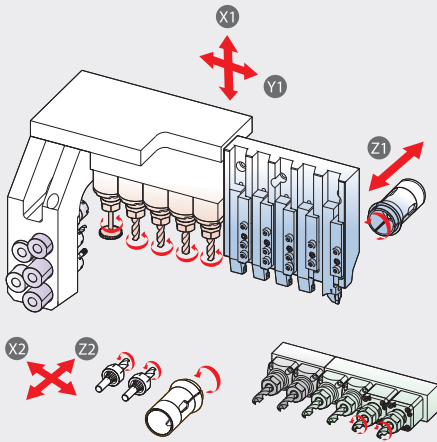

- OPTION**
- Off-center drill (Driven, Fixed) 2
 - Cross 6
 - B-axis tool post 6 (Front 3 + Back 3)
 - Back tool 4 ~ 6
 - Y2 back tool cross unit (Max. Cross 2)

TOOLING VARIATION

- Y2 Back tool 8 (Driven max. 8)
- Off-center drill (Driven) 2

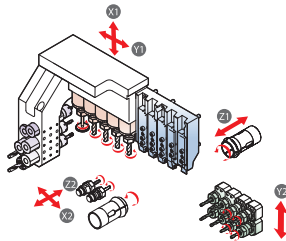

- B-axis tool post 6 (Front 3 + Back 3)

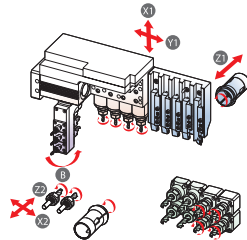

Model	XD32/38II			
	H	N	NH	He
NC	Fanuc 32i-B			Hanwha Fanuc-i
Max. machining diameter	Ø32/38			
Z1 Stroke (mm)	320	80	142 (H), 80 (N)	320
Main spindle rpm	6,500			
spindle kW	5.5/7.5			
OD tool No. of tools	5 (□16mm)			
Front tool No. of tools	5 (ER20M, Ø32)			
Cross drill	No. of tools	5 (ER16)		
	rpm	6,000		
	kW	2.2		
Off-center drill (Option)	No. of tools	2 (ER16) Modular	2 (ER16) Non-modular	
	type	Motor drive (6,000rpm, 1.0kW)		Gear drive
Sub spindle	rpm	6,500 (Built-in motor)	6,500 (Spindle motor)	
	kW	2.2/5.5	1.1/3.7	
Back tool	No. of tools	6 (ER16) (4 Fixed + 2 Driven)	4 (ER16) (2 Fixed + 2 Driven)	
	rpm	6,000		
	kW	1.0		
Machine size (L x W x H) (mm)	2,570 x 1,440 x 1,740			
Weight (kg)	3,600			
Power Consumption (Cable size)	25kVA, 16.7kW (VCTF 16SQ x 4C)			
Air Flow rate (Liter/Min)	120 ~ 150			

* H : G/B, N : Non-G/B, NH : Convertible G/B, He : Hanwha Fanuc-i NC (with G/B)

Dimension

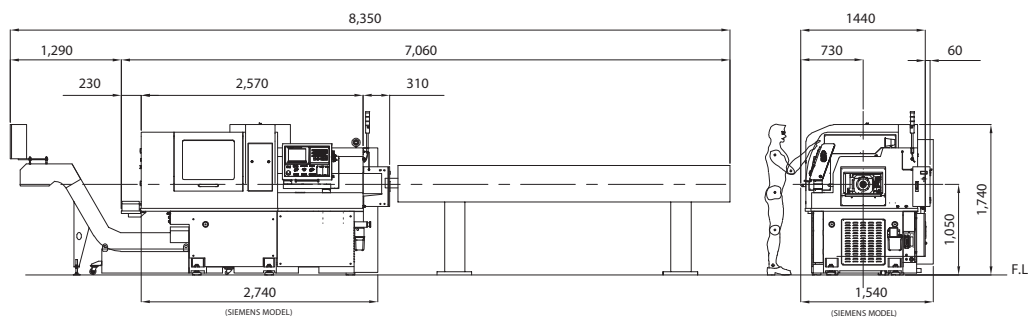

Option Tooling

Various tooling options & sub-spindle type are offered for high-quality performance depending on product & machining condition

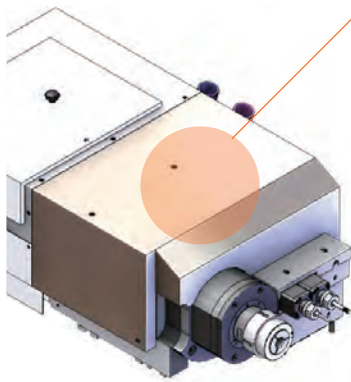

Sub Spindle Unit

- Built-in motor for powerful cutting and spindle motor for high productivity are both available
- ※ Choose a right type of motor to generate the best performance depending on processing material and condition

Sub spindle		Spec	
Max. machining diameter		Ø38 mm	
Rotating speed		6,500 rpm	
Motor spec	Built-in motor	Fanuc 32i-B	2.2/5.5kW, 20/49Nm
	Spindle motor	Hanwha Fanuc-i	1.1/3.7kW, 7/28Nm

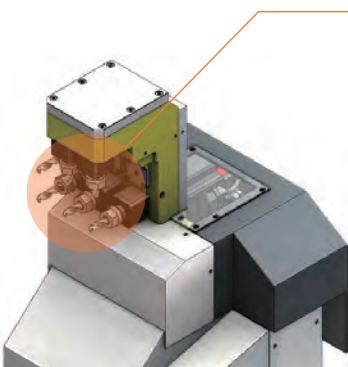

Back Tool Unit

- A total of 8 tools with Y2-axis and modular type for easy tool change / maintenance

Option unit

Attachable fixed drill unit

Off-center can be available with 1 drill unit

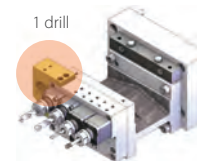

Option tool



Selectable modules of back tool

Driven max. 4



※ Unable to use Off-center for 5 ~ 6 tools

※ Tool distance : 40mm

Standard

- Main-Sub Cs control (0.001°)
- Rotary Guide bush holder
- Cross drilling · milling unit (5, Gear modular type)
- MPG
- Part conveyor
- Door interlock
- Coolant flow sensor
- Work light
- Signal lamp (3color)
- LAN port
- Tool monitoring function
- Cut off tool breakage detector (S/W)
- Auto power off
- Bar feeder interface

Option

- Bar feeder
- Chip conveyor
- Transformer
- Tap breakage detector
- Pipe type ejection unit
- Off center drill unit (2)
- Middle / High pressure pump
- Oil mist collector
- Oil chiller
- Memory card
- Tooling & Programming
- Internal coolant driven tool (cross, back, off-center)
- 3 Face/counterface driven tool (cross)
- 3 Face/counterface angle driven tool (cross)
- Extended coolant tank
- NC warranty for 2 years

XD38II-R

The latest 5/6-axis, specialized in heavy duty cutting/ milling of max. dia. 38mm

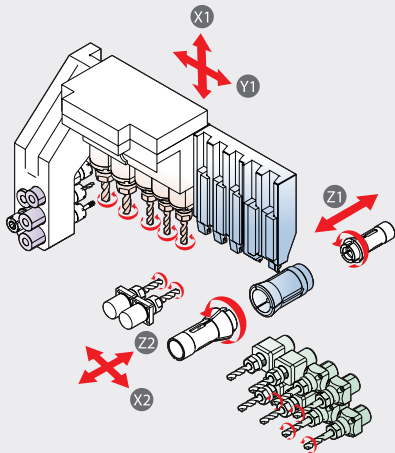

OPTION

- Off-center drill (Driven, Fixed) 2
- Cross 6
- Y2 back tool cross unit (Max. Cross 2)

Specification of G/B & Chuck

Model	XD38II-R		XD38II	
	Fanuc / Siemens	Fanuc	Siemens (※ Production stop)	
NC	Fanuc / Siemens	Fanuc	Siemens (※ Production stop)	
Type	NH	H/N/NH/He	H	N/NH
Guide bush	BRA-42	TD38	BRA-42	
Main chuck	TF48	TF44	TF48	TF44
Sub chuck	TF48	TF44	TF48	

- Enhanced machining performance with optimized structure/ layout & widened distance between tools
- Easy switching between G/B & Non G/B and enhanced stroke, rigidity and chip disposal
- Flexible material feeding solution (bar feeder, automation unit and robot)

Model	XD38II-R	
	NH	
NC	Fanuc 32i-B / Siemens 828D	
Max. machining diameter	Ø38 (Option : Ø40)	
Z1 Stroke (mm)	320 (H), 120 (N)	
Main spindle	rpm	6,500
	kW	5.5/7.5 (Fanuc), 23 (Siemens)
OD tool	No. of tools	5 (□20mm x 2, □16mm x 3)
Front tool	No. of tools	5 (ER20M, Ø32)
	No. of tools	5 (ER20 x 2, ER16 x 3)
	rpm	6,000
Cross drill	kW	2.2 (Fanuc), 2.13 (Siemens)
	No. of tools	2 (ER16) Modular
Off-center drill (Option)	rpm	6,500
	kW	2.2/5.5 (Fanuc), 23 (Siemens)
Sub spindle	No. of tools	8 (ER16) (4 Fixed + 4 Driven)
	rpm	6,000
	kW	1.0 (Fanuc), 1.02 (Siemens)
Machine size (L x W x H) (mm)		2,650 x 1,600 x 1,790
Weight (kg)		4,600
Power Consumption (Cable size)		25kVA (Siemens : 40kVA), 16.7kW (VCTF 16SQ x 4C)
Air Flow rate (Liter/Min)		120 ~ 150

* NH : Convertible G/B

Dimension

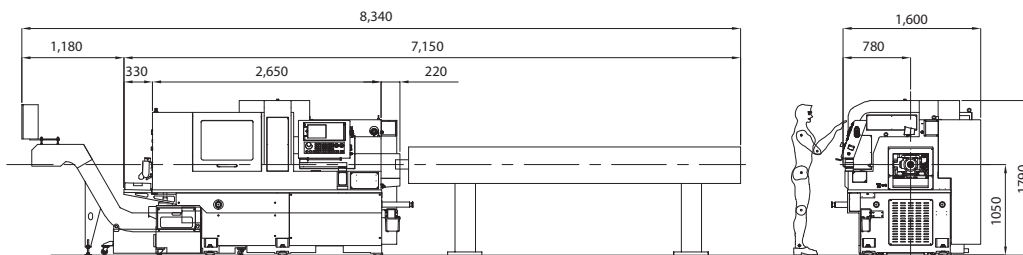

Optimized Structure & Spec for Ø38mm

Possible to machine max. Ø40mm (Option)

Stroke

- Extended stroke to cover various & flexible processing
 - Widened distance between tools
 - Upper size of tools
 - Extended stroke of Z1 for convertible type of G/B (G/B : 205mm → 320mm, Non-G/B : 80mm → 120mm)

Z1	X1	Y1	Z2	X2	Y2
320 (G/B) 120 (Non-G/B)	80	467 (+55*)	350 (+70*)	450 (+55*)	67.7

* : increased stroke compared to XD38II

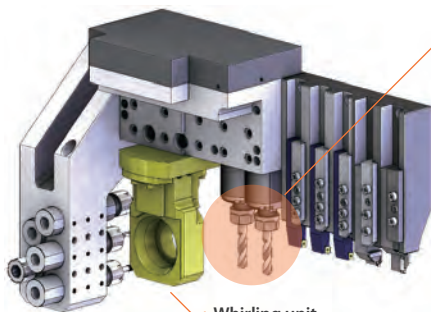

Whirling unit

※ Other various option units are available

Cross Drilling / Milling Unit

- Powerful cross machining
 - Adopted the best-in-class motor (Capacity : Fanuc 2.2kW, Siemens 2.13kW)
- Gear driven modular
 - Gear modular type as standard for various tooling and easy tool change / maintenance

Specification

6,000rpm, 2.2kW(Fanuc), 2.13kW(Siemens)
5 tools (ER20 x 2, ER16 x 3)

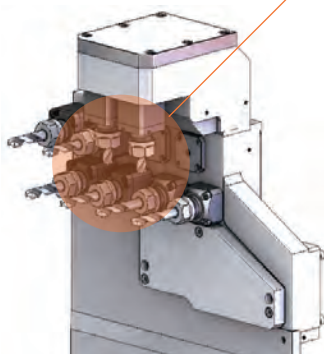

Back Tool Unit

- Optimized structure for machining large bore material
- Extended tooling layout (Distance between tools : 52mm)
- Various option toolings are available
- Less chip trouble structure

Specification

6,000rpm, 1.0kW(Fanuc), 1.02kW(Siemens)
8 tools (4 Driven + 4 Fixed)

Option tool



Internal coolant driven tool



Back tool cross unit (Modular)



Back tool cross unit (Single body)

Standard

- Main · Sub Cs control (0.001°)
- Rotary Guide bush holder
- Cross drilling · milling unit (5, Gear modular type)
- MPG
- Part conveyor
- Door interlock
- Coolant flow sensor
- Work light
- Signal lamp (3color)
- LAN port
- Tool monitoring function
- Cut off tool breakage detector (S/W)
- Auto power off
- Bar feeder interface

Option

- Bar feeder
- Chip conveyor
- Right-way part conveyor
- Transformer
- Tap breakage detector
- Pipe type ejection unit
- Off center drill unit (2)
- Middle / High pressure pump
- Oil mist collector
- Oil chiller
- Memory card
- Tooling & Programming
- Internal coolant driven tool (cross, back, off-center)
- 3 Face/counterface driven tool (cross)
- 3 Face/counterface angle driven tool (cross)
- Extended coolant tank
- NC warranty for 2 years

XD42

Specialized 5/6-axis for larger dia. machining (42mm)

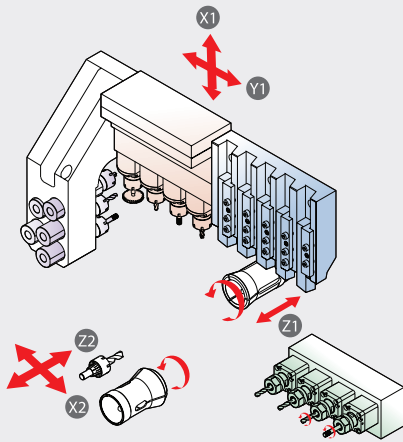

OPTION

- Off-center drill (Driven) 1
- Back tool 4 ~ 6, Y2 back tool post 6 ~ 8

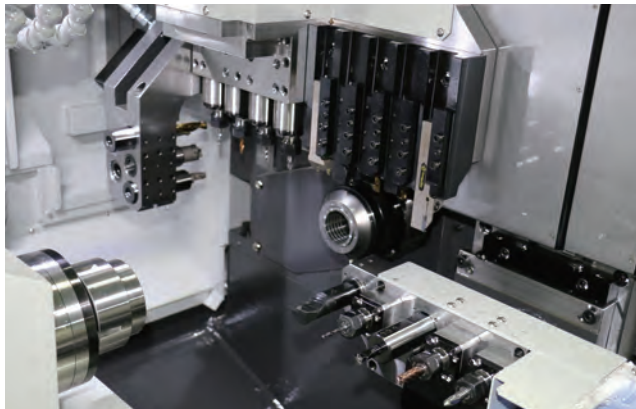

- Strong machining performance & high-productivity for large bore material
- Strong chucking force with hydraulic cylinder
- Improved bearing system for accuracy
- High rigidity of feed unit (Adopted linear roller guide)

Model		XD42		
		H	NH	N
NC		Hanwha Fanuc-i		
Max. machining diameter		Ø42		Ø45
Z1 Stroke (mm)		320	207 (H), 100 (N)	100
Main spindle	rpm	6,000		
	kW	5.5/7.5		
OD tool	No. of tools	5 (□20mm)		
Front tool	No. of tools	5 (ER20M, Ø32)		
Cross drill	No. of tools	4 (ER20M)		
	rpm	6,000		
	kW	2.2		
Off-center drill (Option)	No. of tools	1 (ER20M)		
	type	Gear drive (Modular type drill)		
Sub spindle	rpm	6,000		
	kW	2.2/5.5		
Back tool	No. of tools	5 (ER20M) (3 Fixed + 2 Driven)		
	rpm	6,000		
	kW	1.0		
Machine size (L x W x H) (mm)		2,570 x 1,750 x 1,750		
Weight (kg)		4,100		
Power Consumption (Cable size)		25kVA, 16.7kW (VCTF 16SQ x 4C)		
Air Flow rate (Liter/Min)		120 ~ 150		

* H : G/B, N : Non-G/B, NH : Convertible G/B

Dimension

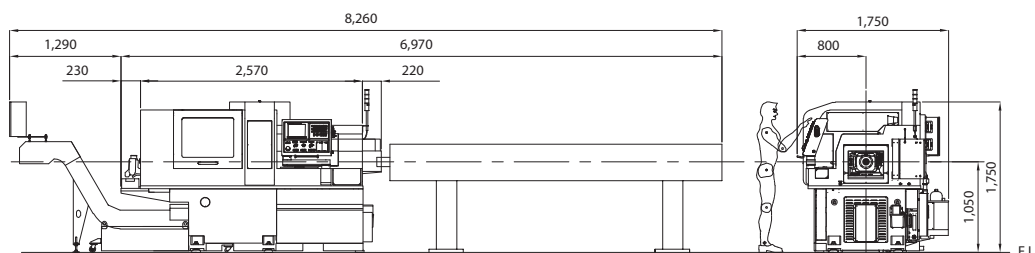

Option Tooling

Offers various and flexible toolings for enhancing productivity and covering a variety of customer's needs

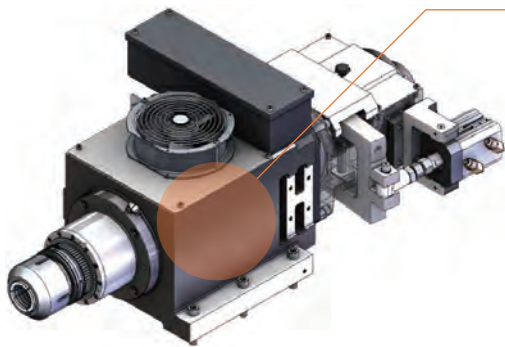

Spindle Unit

- Adopted built-in motor, hydraulic chucking cylinder & 3 toggle system for strong chucking power for Ø42mm material

Specification

6,000rpm
5.5/7.5kW (20 ~ 49Nm)

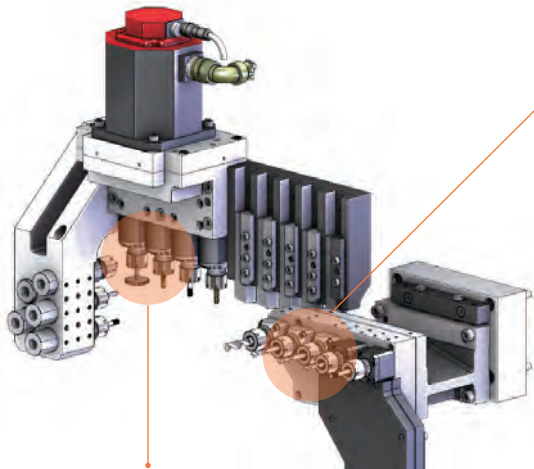

Back Tool Unit

- A total of 8 tools with Y2-axis and modular type for easy tool change / maintenance

Specification

6,000rpm, 1.0kW (3 ~ 7.5Nm)
5 tools (ER20M)

Option tool



Internal coolant driven tool



Fixed angle drilling unit (1-axis)

Cross Drilling / Milling Unit

- Powerful cross machining with upper size of tools and the best-in-class motor
- Cross unit with gear modular type as standard for various tooling and easy tool change / maintenance

Specification

6,000rpm, 2.2kW (8 ~ 22Nm)
4 tools (ER20M)

Selectable modules of back tool

Driven max.4



4 tools (2 + 2)



5 tools (2 + 3)
(Unable to use Off-center)



6 tools (Driven max. 5)
※ Tool distance : 50mm



8 tools (Driven max. 5)
※ With attachable fixed back tool unit (2 drills)
※ Unable to use Off-center

Standard

- Main · Sub Cs control (0.001°)
- Rotary Guide bush holder
- Cross drilling · milling unit (4, Gear modular type)
- MPG
- Part conveyor
- Door interlock
- Coolant flow sensor
- Work light
- Signal lamp (3color)
- LAN port
- Tool monitoring function
- Cut off tool breakage detector (S/W)
- Auto power off
- Bar feeder interface

Option

- Bar feeder
- Chip conveyor
- Transformer
- Tap breakage detector
- Pipe type ejection unit
- Off center drill unit (2)
- Middle / High pressure pump
- Oil mist collector
- Oil chiller
- Memory card
- Tooling & Programming
- Internal coolant driven tool (cross, back, off-center)
- 3 Face/counterface driven tool (cross)
- 3 Face/counterface angle driven tool (cross)
- Extended coolant tank
- NC warranty for 2 years

STL32/38

Turret type, sliding head machine (9-axis) with powerful Siemens 840D controller

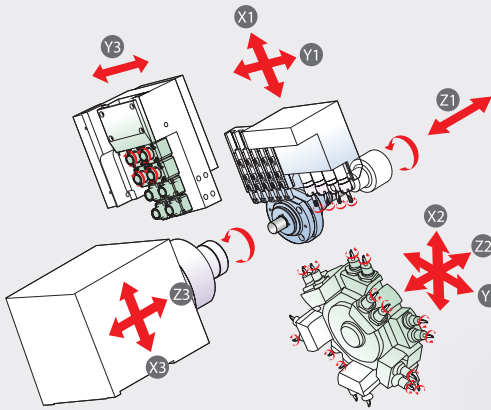

OPTION

• Y3 back tool (Driven 4 + Fixed 4) 8

COMPLEX MACHINING

Combination of gang & turret unit and 3 path control system enables complex machining in various shapes

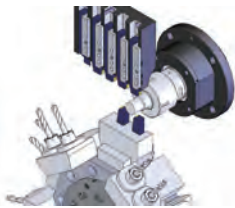

Balance cutting (OD +Turret)

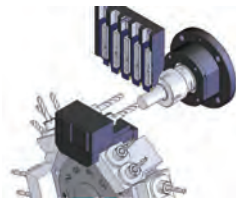

Turning / drilling (OD +Turret)

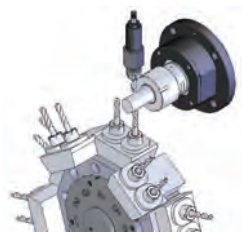

Endmill (Cross+Turret)

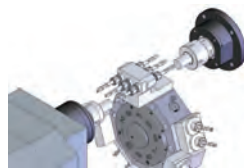

Drilling (Front+Back)

Model	STL32/38	
	-	Y3
NC	Siemens 840D	
Max. machining diameter	Ø32/38	
Z1 Stroke (mm)	320	
Main spindle	rpm	6,500
	kW	23
OD tool	No. of tools	5 (□16mm)
	No. of tools	4 (ER20M)
Cross drill	rpm	6,000
	kW	1.07
	No. of unit	1 Unit (10 Station)
Turret unit	No. of tools	max. 30 (□20, ER20)
	Tool type	VDI 30 (Option : BMT 45)
	rpm	6,500
Sub spindle	kW	23
	Back tool	No. of tools
rpm		6,000
kW		1.07
Machine size (L x W x H) (mm)	3,130 x 1,860 x 1,780	
Weight (kg)	4,400	4,500
Power Consumption (Cable size)	40kVA, 26.7kW (VCTF 16SQ x 4C)	
Air Flow rate (Liter/Min)	20 ~ 30 (Hydraulic device capacity : 30L)	

Dimension

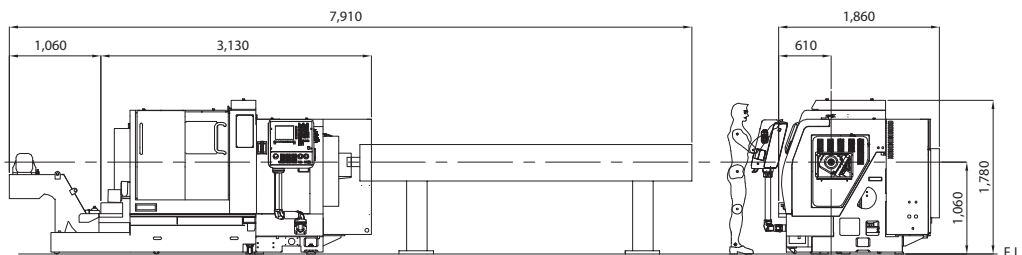

Option Tooling

Max. 47 tools with gang & turret tool post are available, and customized high-complex tooling service is offered

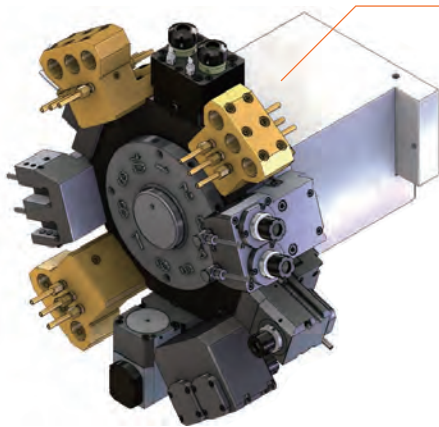

Turret Unit

- Type of turret unit is selectable; VDI (standard) or BMT (Option)

- 1set turret (10 station)
- Tool holder type : VDI30, BMT45
- Tool size : □20, ER20
- Max. number of tools : 30

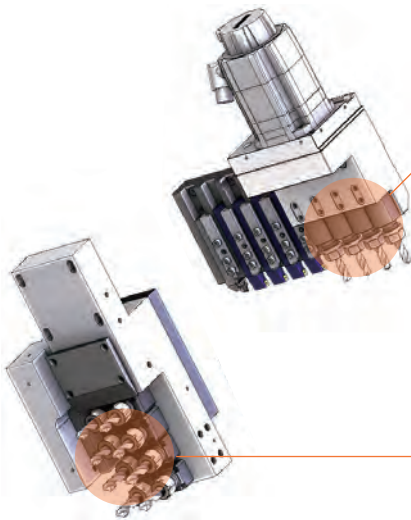
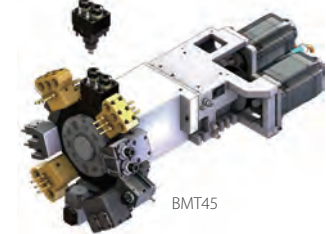
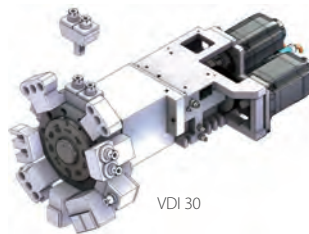

Cross Drilling / Milling Unit

- Easy tool change for maintenance & installation

Option tool



Internal coolant driven tool
※ Spline modular

Back Tool Unit

- Fixed 3 tools as standard and 8 tools of Y3 (4 driven, 4 fixed, ER20M) are available in modular type

Specification of G/B & Chuck

No. of Back tool	3 Fixed	4 Fixed	8 (4 Driven + 4 Fixed, Y3)
G/B	HW38	HW38	HW38
Main Chuck	TF48	TF48	TF48
Sub Chuck	TF48	TF44	TF44

Option tool & unit



Internal coolant driven tool



Multi finger tool
(Re-adjust machining point)



3 ~ 4 tools



8 tools
(Max. 4 Driven)

Standard

- Main-Sub Cs control (0.001°)
- Rotary Guide bush holder
- MPG
- Chip conveyor
- Part conveyor
- Door interlock
- Work light
- Signal lamp (3color)
- Tool monitoring function
- Cut off tool breakage detector (S/W)
- Auto power off
- Bar feeder interface
- Middle pressure pump

Option

- Bar feeder
- Transformer
- Tap breakage detector
- High pressure pump
- Oil mist collector
- Oil chiller
- Memory card
- Tooling & Programming
- Internal coolant driven tool (cross, back, off-center)
- NC warranty for 2 years
- Turret unit (BMT45)
- Turret Tool Holder

STL42

Specialized 9-axis turret type sliding head machine with powerful Siemens 840D controller (42mm)

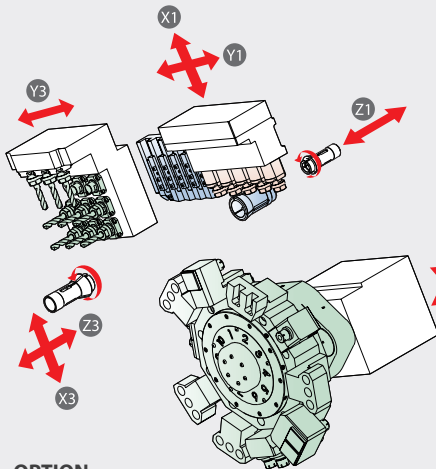

OPTION

- Back tool cross 9 (Cross 3, Driven 3 + Fixed 3)

OPTIMIZATION OF STRUCTURE & SPEC

Adopted built-in motor with hydraulic chucking cylinder for strong chucking power

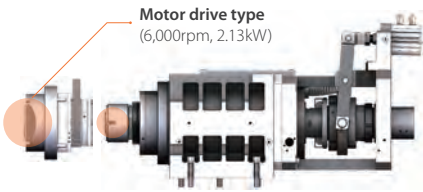

Unit	Spec
G/B	HW38
Chuck (Main, Sub)	TF48

UPGRADED SOFTWARE PLATFORM

Provides the new HMI screen and improved software functions for machining & operating convenience

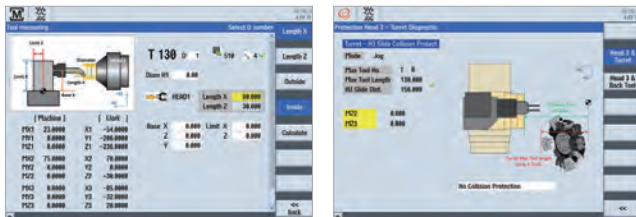

Tool measuring

Collision protection

Model	STL42	
	H	NH
NC	Siemens 840D	
Max. machining diameter	Ø42	
Z1 Stroke (mm)	420	282 (H), 125 (N)
Main spindle	rpm	6,000
	kW	22
OD tool	No. of tools	5 (□20mm)
	No. of tools	5 (ER20)
Cross drill	rpm	6,000
	kW	2.59
	No. of unit	1 Unit (10 Station)
Turret unit	No. of tools	max. 30EA (□20, ER20)
	Tool type	VDI 30 (Option : BMT 45)
	rpm	6,000
Sub spindle	kW	22
	No. of tools	9 (ER20) (3 Fixed + 6 Driven)
Back tool	rpm	6,000
	kW	2.13
	Machine size(L x W x H) (mm)	3,580 x 2,060 x 1,980
Weight (kg)	7,330	
Power Consumption (Cable size)	40kVA, 26.7kW (VCTF 16SQ x 4C)	
Air Flow rate (Liter/Min)	20 ~ 30 (Hydraulic device capacity : 30L)	

Dimension

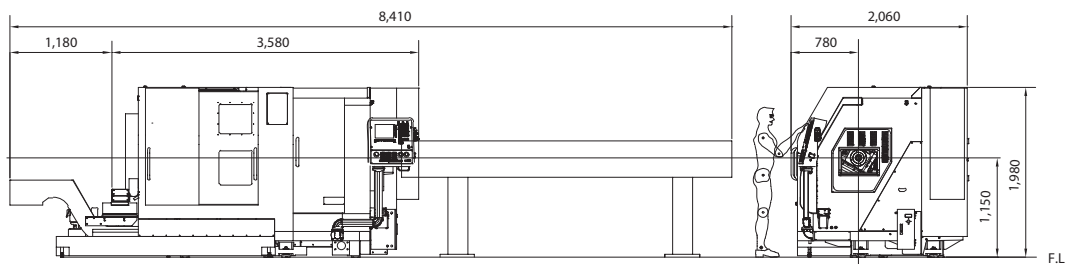

Option Tooling

Max. 49 tools with gang & turret tool post are available, and structure, spec & tooling are optimized for material 42mm

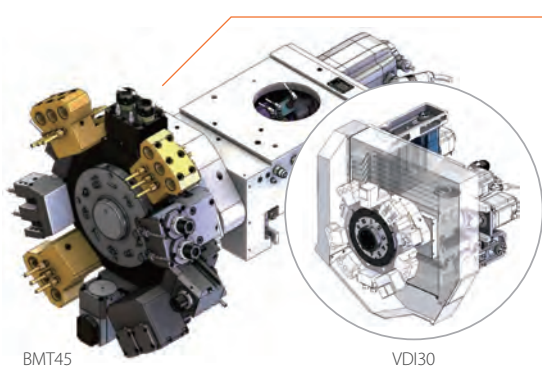

Turret Unit

- Type of turret unit is selectable; VDI (standard) or BMT (option)
- Adopted SRG(Roller retainer) LM guide for feed of turret unit

Specification

- Driven : 6,000rpm, 2.59kW
- Tool size : □20, ER20
- 10 station
- Max. number of tools : 30
- Tool holder type : VDI30(standard), BMT45(option)

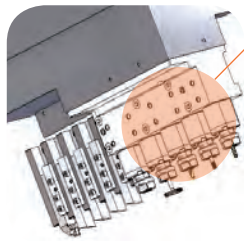

Cross Drilling / Milling Unit

- Optimized structure for machining large bore material
- Extended distance between tools & increased no. of tools

Specification (STL38 → STL42)

- Tool distance : 35mm → **60mm**
- Tool spec : 4(ER20M) → **5(ER20)**
- Motor spec : 6,000rpm, 1.07kW → **2.13kW**

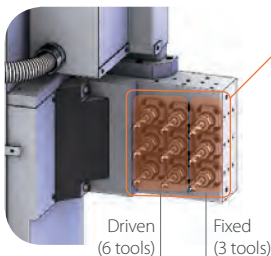

Back Tool Unit

- Enhanced machining capability with Y3-axis feed & increased no. of tools for back
- Simultaneous processing & high complex machining with back tool cross unit (option)

Specification (STL38 → STL42)

- Tool distance : 40mm → **60mm**
- Tool spec : 8(ER20M) → **9(ER20)**
- Motor spec : 6,000rpm, 1.07kW → **2.13kW**

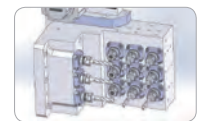

※ Back tool Cross unit (Option)
→ No. of tools : Back tool 6, Cross 3

COMPLEX MACHINING



Balance turning (OD+Turret)



Turning/drilling (OD+Turret)



Endmill (Cross+Turret)



Drilling (Front+Back)

Standard

- Main-Sub Cs control (0.001°)
- Rotary Guide bush holder
- MPG
- Chip conveyor
- Part conveyor
- Door interlock
- Work light
- Signal lamp (3color)
- Tool monitoring function
- Cut off tool breakage detector (S/W)
- Auto power off
- Bar feeder interface
- Middle pressure pump

Option

- Bar feeder
- Transformer
- Tap breakage detector
- High pressure pump
- Oil mist collector
- Oil chiller
- Memory card
- Tooling & Programming
- Internal coolant driven tool (cross, back, off-center)
- NC warranty for 2 years
- Turret unit (BMT45)
- Turret Tool Holder

Options

Customized special option units are available for qualified performance, enhanced productivity and convenience

Standard & Option Accessory		XE series		XP series		XD series				
		XP12/16S	XP20/26/32S	XE20/26	XE35	XD03/07	XD12/16III	XD20/26II	XD20/26II-V	
Off-cent unit	Driven(2)	-	-	★	★(1)	-	-	★	★	
	Fixed (long drill, 2)	-	-	★	-	-	★(1)	★	★	
	Off-center Tailstock	-	-	★	★	-	-	★	★	
Intenal coolant driven unit	Cross	-	-	★	★	-	★(Modular)	★	★	
	Back	-	-	★	★	-	-	★	★	
	Off-center	-	-	★	★	-	-	★	★	
Fixed angle drilling unit	Cross, 1	-	-	▲	▲	-	-	▲	▲	
	Back, 1	-	-	▲	▲	-	-	▲	▲	
Option tool unit	Triple speed cross drill	-	-	★	★	-	★(Modular)	★	★	
	Triple speed reduction cross drill	-	-	★	★	-	★(Modular)	★	★	
	3 Face/counterface driven tool	-	-	★	★	-	-	★	★	
	3 Face/counterface angle driven tool	-	-	★	★	-	-	★	★	
	Gear hobbing	★	-	★	★	▲	▲	★	★	
	Whirling	-	-	★	★	-	★	★	★	
	Side cutter	Back	-	-	★	★	-	★	★	★
		Modular(Y2)	-	-	-	-	-	-	-	★
		Single body(Y2)	-	-	-	-	-	-	-	★
	Horizontal	-	-	★	★	-	-	★	★	
Coolant unit	Chiller integrated High pressure coolant pump	▲	★	★	★	-	★	★	★	
	Extended coolant tank	★	★	★	★	-	★	★	★	
Chip conveyor	Standard chip conveyor	★	★	★	★	-	★	★	★	
	Smart chip conveyor	-	-	★	-	-	-	★	★	
	Lower type chip conveyor	★	★	★	★	-	★	★	★	

Tooling Variation

XD20/26II

- Front/Back Tool
- Cross Drill
- Special Option Tool
- OD Tool

Cross 4

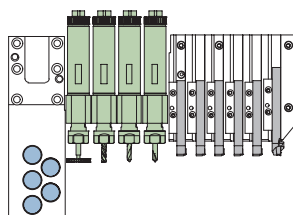

Cross 5

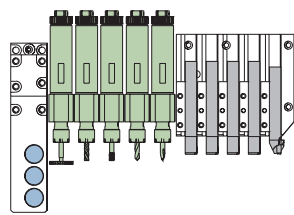

Cross 6

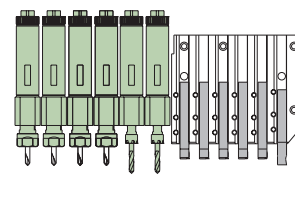

3 Face/counterface angle driven tool

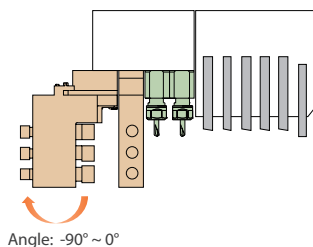
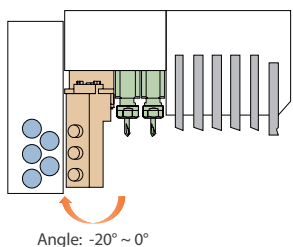

3 Face/counterface driven tool

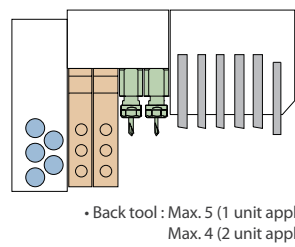

Whirling

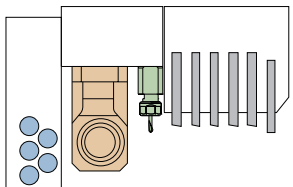

Gear Hobbing

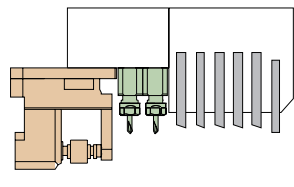

Polygon

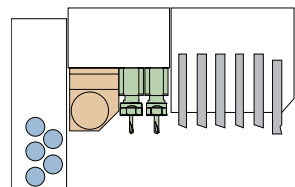

※ When special tool is installed, back tool unit should have max. 4 tools

Special Accessories

	XD series			STL series	
	XD38II	XD38II-R	XD42	STL38	STL42
	★	★	★(1)	-	-
	★(1)	★(1)	-	-	-
	★	★	★	-	-
	★	★	★	★	★
	★	★	★	★	★
	★	★	★	-	-
	★	★	★	★	★
	★	★	★	★	★
	★	★	★	★	★
	★	★	★	-	-
	★	★	★	★(Turret)	★(Turret)
	★	★	★	★	★
	★	★	★	★(Turret)	★(Turret)
	★	★	★	-	-
	★	★	-	-	★(Y3)
	★	★	★	-	-
	★	★	★	★	★
	★	★	★	-	-
	★	★	★	-	-
	★	★	★	-	-
	★	★	★	★	★

★ : Option ▲ : Discussable - : N/A

Swing Gripper

Gripper fingers to grip and release finished parts on to conveyor belt for ejection
 - Applied example : vulnerable material, long parts
 • XD20/26II, XD38II, XD42, XE20/26

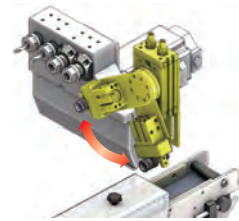

Parts Auto Loading unit

Auto loader for forged or diecasted parts to supply through main spindle door
 • XD20/26II, XD38II, XD42, XE20/26



Auto stacking unit for machined parts

Auto loader for ejected parts onto a stacking pallet
 • XD38II



XD38II

- Front/Back Tool
- Cross Drill
- Special Option Tool
- OD Tool

Cross 5

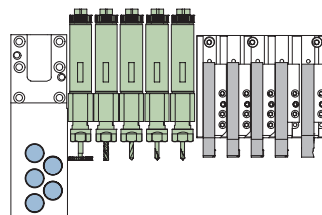

Cross 6

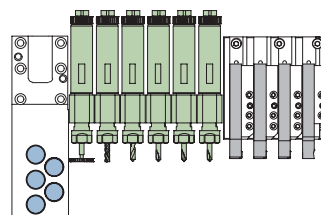

B-axis unit

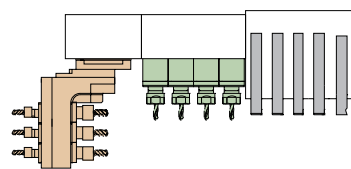

• 3 Face driven tool can be limited the number of back tool

Fixed Angle Drilling

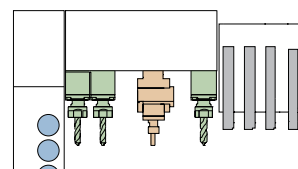

• Angle will be set as per requested

Back Tool Option Unit (Y2)

Fixed Angle Drilling

• Angle will be set as per requested



Back tool cross

(Modular, Single body)

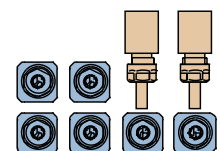

※ When special tool is installed, back tool unit should have max. 4 tools
 ※ Back tool option is available for both 6(Y2) and 8(Y2)

KCG Series

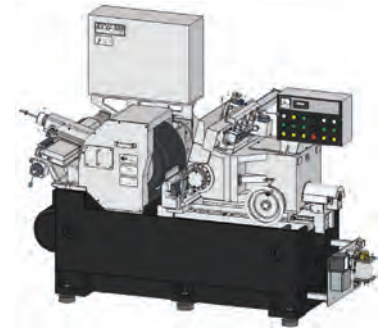
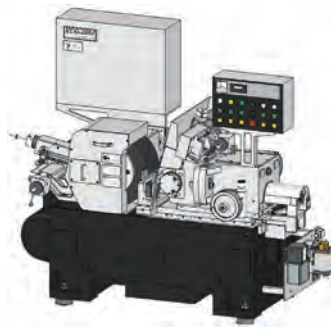
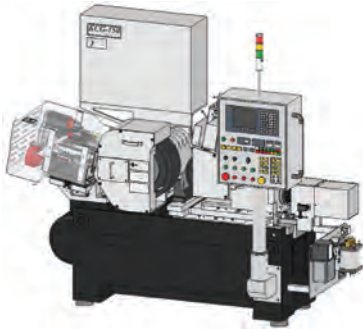

KCG-150 CNC

- B/R type G/W to secure accuracy
- Heat-treated slide and Anti-backlash gear to enhance repeatability of G/W Dresser
- Optimized design for installation of automation unit

KCG-200J

- Micro feeding unit
- Maximized wear resistance with turcite type of feeding table
- Selectable for Hydro-dynamic or B/R type of G/W

KCG-200/300 (CNC)

- Single grip G/W spindle for easy replacement of wheel
- Twin grip type of R/W for better precision
- Selectable for Hydro-dynamic or B/R type of G/W

Model		KCG-150 CNC	KCG-200J	KCG-200 (CNC)	KCG-300 (CNC)
Grinding	Max.grinding dia. (mm)	Ø1.0 ~ Ø50	Ø1.5 ~ Ø50	Ø2.0 ~ Ø90	Ø3.0 ~ Ø120
	Max.grinding length (l/F) (mm)	145	-	200	300
Grinding wheel (G/W)	Size(O.DxWxl.D) (mm)	Ø455 x 150 x Ø228.6	Ø510 x 205 x Ø254	Ø610 x 205 x Ø304.8	Ø610 x 305 x Ø304.8
	Peripheral velocity (m/min)	2,400	2,400	2,400	2,400
Grinding wheel (R/W)	Size(O.DxWxl.D) (mm)	Ø305 x 150 x Ø177.8	Ø305 x 205 x Ø152.4	Ø305 x 205 x Ø152.4	Ø330 x 305 x Ø152.4
	Rotational velocity (rpm)	10 ~ 200	10 ~ 200	10 ~ 200	10 ~ 200
G/W dressing unit	Traverse of diamond tool	Servo motor	Hydraulic	Hydraulic	Hydraulic
	Feed of diamond tool	Servo motor	Manual	Manual	Manual
R/W dressing unit	Traverse of diamond tool	Hydraulic	Hydraulic	Hydraulic	Hydraulic
	Feed of diamond tool	Manual	Manual	Manual	Manual
Motor	Grinding wheel driving (kW)	11	11	15	22
	Regulating wheel driving (kW)	1.5	2.2	2.2	3
Installation	Installation area (L x W) (mm)	2,300 x 1,700	2,300 x 1,700	2,900 x 2,500	3,000 x 2,700
	Weight (kg)	3,000	3,500	5,500	5,700

Dimension

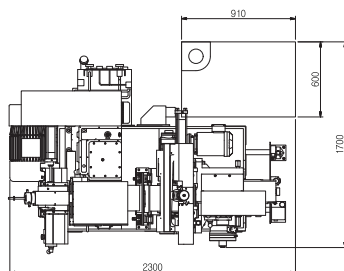

KCG-150/200J CNC

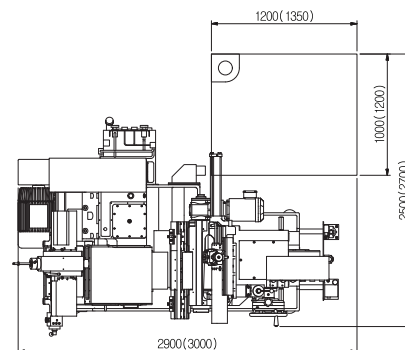

KCG-200/300 CNC

HCG Series

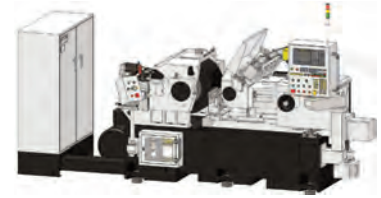
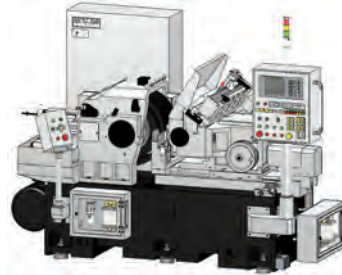
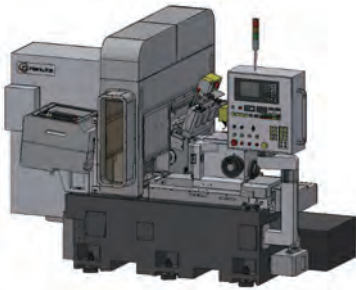

HCG-150 CNC

- Duct for pipe of grinding oil and adopted heat treatment under slide to enhance repeatability and reduce thermal deformation
- Upper slide handle & AC motor for R/W
- Full cover design to prevent coolant leakage

HCG-300 (CNC)

- Twin grip of G/W, R/W spindle for high precision & high stiffness
- Motor type of dresser for user convenience
- Full cover design to prevent coolant leakage

HCG-400 (CNC)

- CNC 4-axis (Max. control 6-axis)
- Twin grip of G/W, R/W spindle for high precision & high stiffness
- Motor type of dresser for user convenience
- Full cover design to prevent coolant leakage

Model		HCG-150 CNC	HCG-300 (CNC)	HCG-400 (CNC)
Grinding	Max.grinding dia. (mm)	Ø1.0 ~ Ø50	Ø3.0 ~ Ø120	Ø3.0 ~ Ø150
	Max.grinding length(l/F) (mm)	150	300	400
Grinding wheel (G/W)	Size(O.DxWxI.D) (mm)	Ø455 x 150 x Ø228.6	Ø610 x 305 x Ø304.8	Ø610 x 405 x Ø304.8
	Peripheral velocity (m/min)	2,600	2,600	2,600
Grinding wheel (R/W)	Size(O.DxWxI.D) (mm)	Ø305 x 150 x Ø177.8	Ø330 x 305 x Ø203.2	Ø330 x 405 x Ø203.2
	Rotational velocity (rpm)	10 ~ 300	10 ~ 200	10 ~ 200
G/W dressing unit	Traverse of diamond tool	Servo motor	Oriental motor	Servo motor
	Feed of diamond tool	Servo motor	Manual	Servo motor
R/W dressing unit	Traverse of diamond tool	Servo motor	Oriental motor	Servo motor
	Feed of diamond tool	Servo motor	Manual	Manual
Motor	Grinding wheel driving (kW)	11	30	37
	Regulating wheel driving (kW)	1.4	3.0	3.0
Installation	Installation area (L x W) (mm)	2,750 x 1,450	2,900 x 2,500	4,500 x 2,750
	Weight (kg)	4,000	7,200	7,700

Dimension

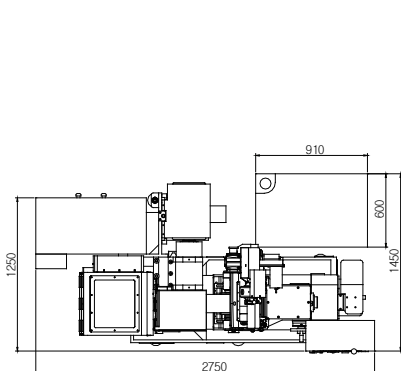

HCG-150 CNC

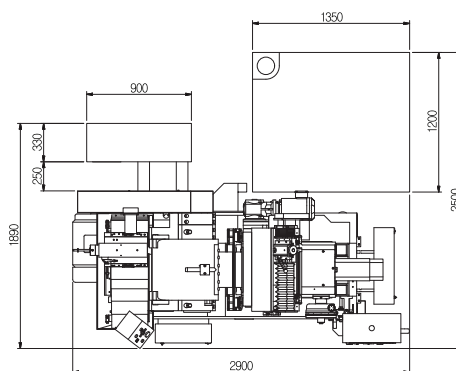

HCG-300 CNC

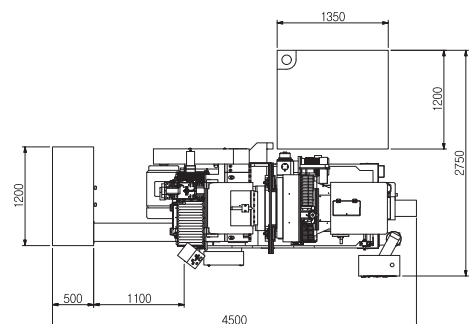

HCG-400 CNC

Structure

G/W Dresser

- 2-axis servo motor
- Adopted Backlash prevention gear to enhance repeatability



Grinding Wheel

- Twin grip type for high rigidity
- High stiffness roller bearing
- Easy maintenance

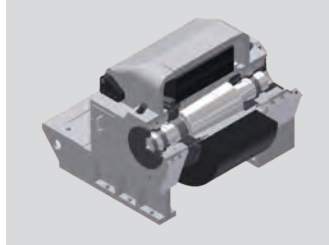

Regulating Wheel

- High stiffness roller bearing for high precision
- Easy maintenance



R/W Feed System

- High precision & rigidity
- Various slide type, turcite, roller guide type etc

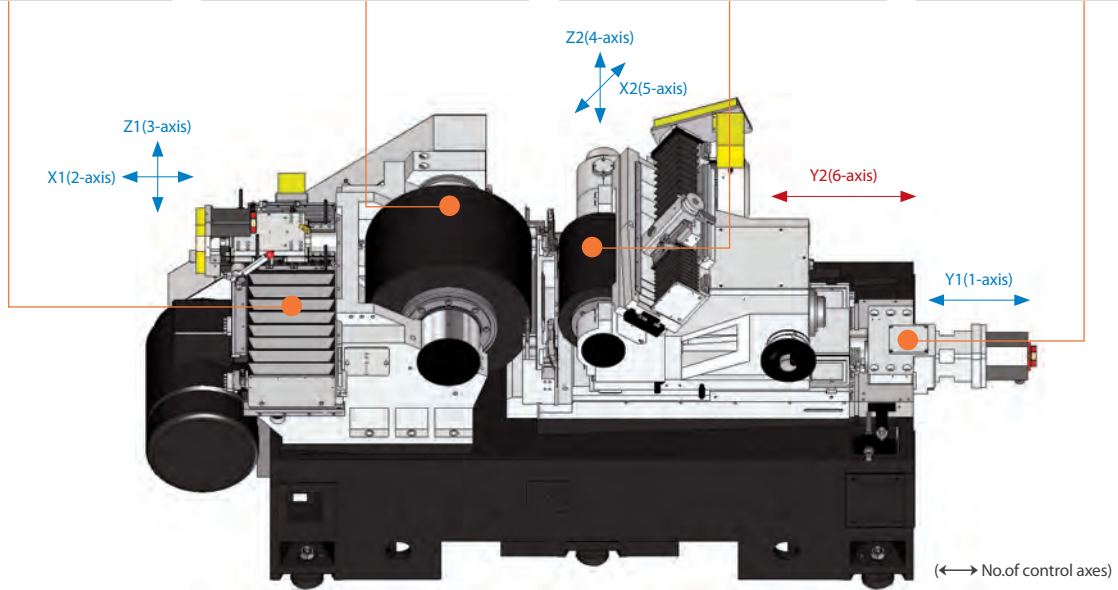
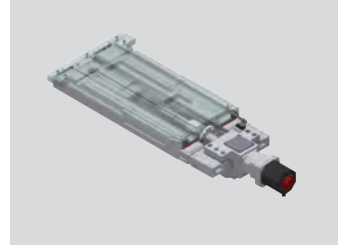

Special Feature

Mist Prevention Cover

KCG Series Cover

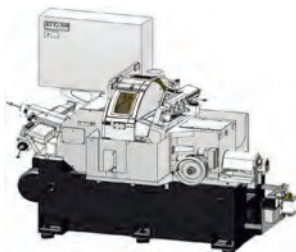

HCG Series Cover

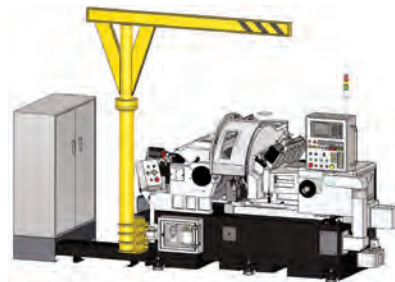

Auto Balance Unit

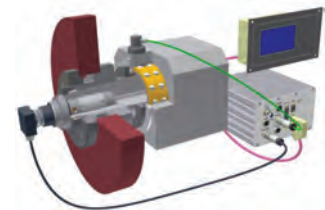

Standard/Option Accessories

Description	KCG-150 CNC	KCG-200J	KCG-200 (CNC)	KCG-300 (CNC)	HCG-150 CNC	HCG-300 (CNC)	HCG-400 (CNC)
Grinding Wheel	○	○	○	○	○	○	○
Regulating Wheel	○	○	○	○	○	○	○
Through Feed Workrest Body	○	○	○	○	○	○	○
Through Feed Blade	○	○	○	○	○	○	○
Guide Plate	○	○	○	○	○	○	○
Coolant Tank	○	○	○	○	○	○	○
Tool Box	○	○	○	○	○	○	○
Wheel Changer Unit	○	○	○	○	○	○	○
Magnetic Separator	○	○	○	○	○	○	○
G/W Auto Dressing Unit (Motor Type)	-	●	●	●	-	●	-
Micro Feeding Unit (Motor Type)	-	●	●	●	-	●	-
Roller Guide Type R/W Slide	×	×	●	●	●	●	●
G/W Exchange Device	×	×	×	×	-	●	●
R/W Exchange Device	-	●	●	●	-	●	●
G/W Balancing Stand Ass'y	●	●	●	●	-	-	-
Auto Balancing Unit	●	●	●	●	●	●	●
Jib Crane	●	●	●	●	●	●	●
CNC Controller	○	●	●	●	○	●	○
Roller Guide Type R/W Dresser	○	●	●	●	○	○	○
Coolant Separator Unit (Paper Filter, Cyclone system, etc)	●	●	●	●	●	●	●
Mist Collector	●	●	●	●	●	●	●
Oil Cooler	-	●	●	●	-	-	-
Coolant Cooler	●	●	●	●	●	●	●
Table Oil Mist	●	●	●	●	●	●	●
G/W Cooling Unit	-	●	●	●	-	-	-
Hydro-Static Type G/W Spindle	●	●	●	●	-	-	-
Bearing Type G/W Spindle	○	●	●	●	○	○	○
In Feed Workrest Body	●	●	●	●	●	●	●
In Feed Blade	●	●	●	●	●	●	●

○ : Standard ● : Option × : Not Applicable - : CNC model includes functions as standard

Measuring Unit

Laser Scan Measuring

- Non-contact type O.D measuring
- Measurement accuracy $\pm 2\mu\text{m}$
- Repeatability $\pm 0.15\mu\text{m}$



Post Process Gauge

- Contact type O.D measuring unit
- Measurement accuracy: Less than $0.1\mu\text{m}$
- Repeatability: Less than $0.2\mu\text{m}$



Automation Unit

Through Feed



In Feed



Hi-CPS

Hanwha Intelligence CNC Prognostic System



Hi-CPS is a kind of smart factory solution to enable customers to manage factory in a smart & convenient way by providing real time onitring on running status of machines at the facility. It is a cloud-based system so that one can access with ease from anywhere through internet.

Function

- 1 Monitoring**
 - Monitors machine operation status from PC & Mobile
 - Check machining, repair, alarm, cycle time, etc.
- 2 Diagnosis**
 - Remotely examines alarmed machines at user's online request
 - ※ Only at customer's request, relevant machine data will be auto-transferred to Hanwha for analysis
- 3 Prognosis**
 - Analyzes cutting load, tool change and offset

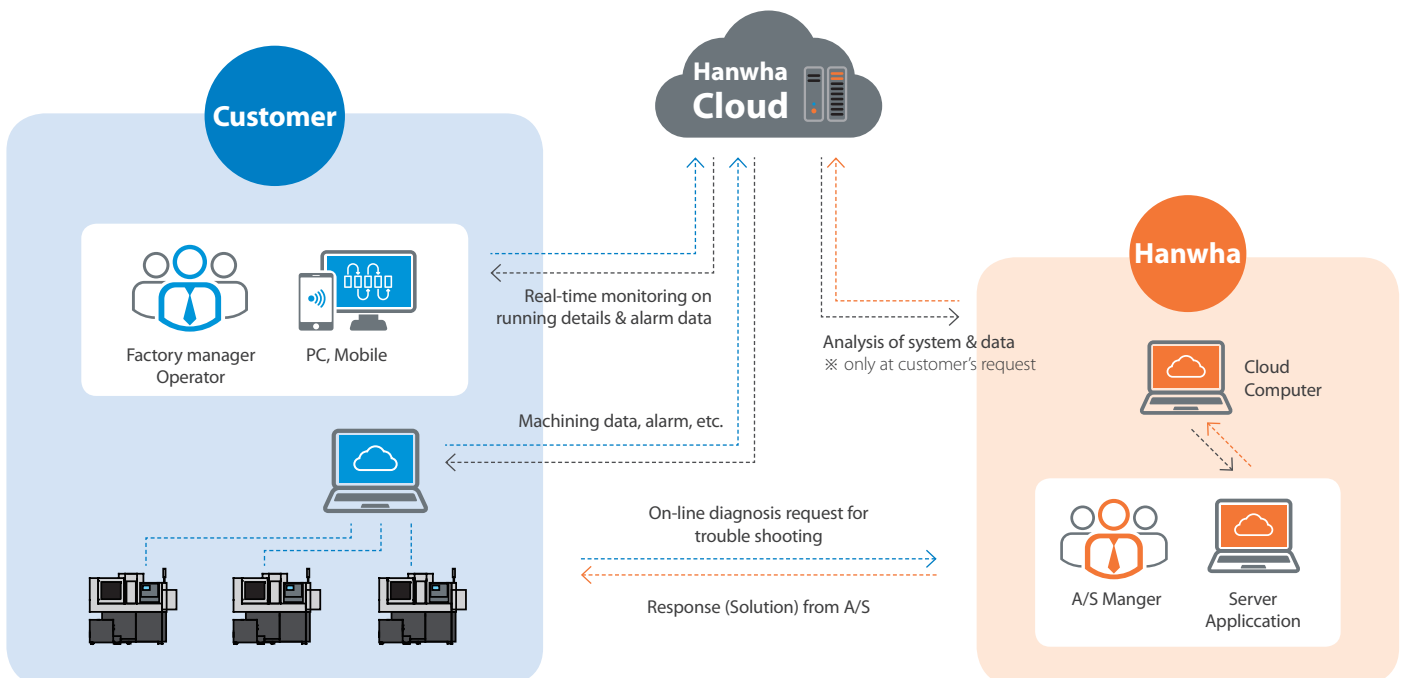

PCR / PCRS & Oscillation

Chip breaking solution



Hanwha provides chip cutting solution to break long and curled chips into small pieces through macro program.

Advantage

- Better tool life
- Build-up edge free
- Chip trouble free
- Coolant usage saved



Model	PCR	PCRS	Oscillation
NC	FANUC 32i-B	SIEMENS 828D/840D	Fanuc 0i-TD / 0i-TF / 32i-B
Front turning	●	●	●
Back turning	●	●	●
Back drilling	Fixed drills	●	Fixed drills
Taper	●	●	45° angle
Circular interpolation	●	●	●
Synchronous control	●	●	x
Threading	●	●	x
Nose R compensation	x	●	x

Customer & Performance Supporting Function

Hanwha offers various software for enhancing machining performance & supporting customer's convenience.

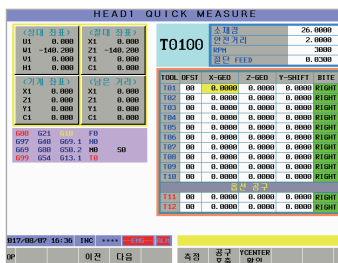

Quick Measuring
Setting time reduce system
Supports tools setting with minimal control and none of screen change

Collision Protection
Easy setting of value to protect collision before occurring

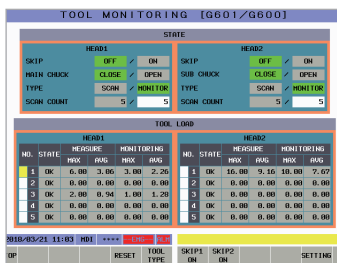

Tool Load Monitoring
Alarms when abnormal load on tools are detected

M7
Single code to command cut-off of material

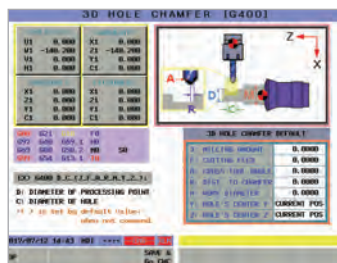

3D Chamfer Solution
Uniform chamfer machining on cross hole with input of single code

G301
Single code to set the position of Z2-axis for cut-off of material

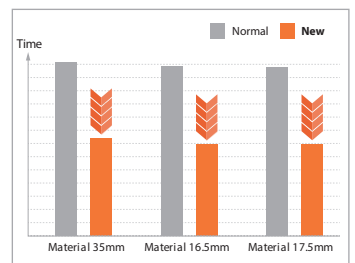

Motion Optimization
C/T reduce system
Reduces cycle time by minimizing unnecessary motion (non processing time)

Help function
Provides description & graphic information about codes & alarms with



Automobile sample



NO. **A001**
Material ADC12



NO. **A002**
Material SUS304



NO. **A003**
Material SCM440H

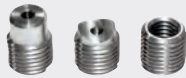

NO. **A004**
Material SUS304



NO. **A005**
Material SUS304



NO. **A006**
Material SUS304



NO. **A007**
Material SUM22



NO. **A008**
Material SUS630



NO. **A009**
Material SUM24



NO. **A010**
Material AL6062-T8



NO. **A011**
Material AL6062-T8



NO. **A012**
Material AL6062-T9



NO. **A013**
Material Brass



NO. **A014**
Material AL-Die Casting



NO. **A015**
Material SUM22



NO. **A016**
Material SUS316



NO. **A017**
Material SUS304



NO. **A018**
Material SUS303



NO. **A019**
Material SCM315



NO. **A020**
Material AL6062



NO. **A021**
Material Brass



NO. **A022**
Material AL6061



NO. **A023**
Material SUS304



NO. **A024**
Material SUM202

















Electronic sample



Industrial sample



Medical sample

NO. Material	 E001 SUS316	 I001 AL6062	 M001 Titanium
NO. Material	 E002 AL6061	 I002 SUS316	 M002 SUS316L
NO. Material	 E003 AL6062	 I003 AL2024	 M003 Titanium
NO. Material	 E004 AL6061	 I004 AL2024	 M004 Titanium
NO. Material	 E005 Brass	 I005 AL6062	 M005 Titanium, Brass
NO. Material	 E006 AL6061	 I006 AL6062	 M006 Titanium, Brass
NO. Material	 E007 Brass	 I007 SUS316	 M007 SUS316
NO. Material	 E008 AL6062	 I008 Brass	 M008 Titanium

Hanwha Precision Machinery / Machine Tool Division

www.hanwhaprecisionmachinery.com

9 Sungsanpaechong-ro, Sungsan-gu, Changwon, Kyungnam, South Korea(59 Sungsan-dong)

Tel. +82-55-280-4678 / +82-55-210-6419 Fax. +82-55-280-8930

Email. mtinfo@hanwha.com



Hanwha Europe GmbH

Kölner Straße 10, 65760 Eschborn Germany

Hanwha Europe GmbH Technical Center

Hessenring 15B, 64546 Mörfelden-Walldorf, Germany

· Tel. +49-(0)-6105-7035-911

· Email. wsjung@hanwha.de

Hanwha TechM (Suzhou) Co., Ltd

North side of Sigang Segment, Zhangyang road, Zhangjiagang Economic and Technology development zone, Zhangjiagang, Jiangsu 215600, China

· Tel. +86-512-8017-9914~5

· Email. pjh1012@hanwha.com

Hanwha Machinery America Inc.

9750 South Oakwood Park Drive, Franklin, WI 53132, USA

www.hanwhamachinery.com

· Tel. +1-414-421-2300

EUROPE

Germany · Italy · Russia · Switzerland · Spain
Belgium · Netherland · Latvia · Ukraine
France · Portugal · Czech Republic · Poland
Hungary · Romania · Belarus · Bulgaria
Finland · Sweden · Turkey

ASIA

China · Hong Kong · India · Philippines
Israel · Thailand · Indonesia · Malaysia
Vietnam

AMERICA

U.S.A · Canada · Brazil · Argentina · Mexico
Venezuela · Costa Rica · Colombia

