

KF-II Series

KF4600 II | KF5600 II | KF6700 II

HYUNDAI WIA Vertical Machining Center

Technical Leader

State-of-the-art Vertical Machining Center with High-speed and large work space

The Vertical Machining Center KF-II Series, designed by Hyundai WIA with years of expertise and the latest technology, maximizes productivity while maintaining rigidity and accuracy.

		KF4600 II	KF5600 II	KF6700 II
Table Size (L×W)	mm(in)	1,050×460 (41.3"×18.1")	1,250×560 (49.2"×22")	1,500×670 (59"×26.4")
Max. Load Capacity	kg(lb)	600 (1,323)	1,000 (2,205)	1,300 (2,866)
Spindle Taper	-	BBT40 [12K, 15K : HSK-A63]	BBT40 [12K, 15K, 20K : HSK-A63]	BBT40 [12K, 15K, 20K : HSK-A63]
Spindle Speed	r/min	Std. 8,000	Std. 8,000	Std. 8,000
Spindle Motor	kW (HP)	18.5/11 (25/15)	18.5/11 (25/15)	18.5/11 (25/20)
No. of Tools	EA	30 [40]	30 [40]	30 [40]
Travel (X/Y/Z)	mm	900/460/520 (35.4"/18.1"/20.5")	1,100/560/520 [635] (43.3"/22"/20.5" [25"])	1,300/670/635 (51.2"/26.4"/25")
Rapid Traverse Rate	m/min	36/36/30	36/36/30 [42/42/36]	36/36/30 [42/42/36]

❖ Please refer to Spindle standard page 38~40 detailed specification table.

[] : Option

KF-III Series

Most Versatile High end Linear Machining Center

- High-precision machining by improved spindle quality
- High-speed roller type LM guide in all axes
- Enhanced chip processing capabilities by applying the upper-type conveyor
- Various motors and columns provided for customized machining
- Improved user convenience by applying the latest controller of FANUC



01 BASIC STRUCTURE

High Speed & Productivity Vertical Machining Center

Magazine

- No. of Tools : 30 [40] EA
- Tool Change Time (C-C) : 3.2 sec
(KF6700II : 3.5 sec)
- Max. Tool Length : 300 mm (11.8")
- BBT40

High Precision Spindle

- Direct Spindle
8,000/10,000/12,000/15,000 rpm
- Built-in Spindle
20,000 rpm
- Spindle Heat Distortion Compensation Device
Standard (Sensorless)

Table

ITEM	Size (X/Y) / Load Capa.
KF4600 II	1,050×460 mm / 600 kg (41.3"x18.1" / 1,323 lb)
KF5600 II	1,250×560 mm / 1,000 kg (49.2"x22" / 2,205 lb)
KF6700 II	1,500×670 mm / 1,300 kg (59"x26.4" / 2,866 lb)

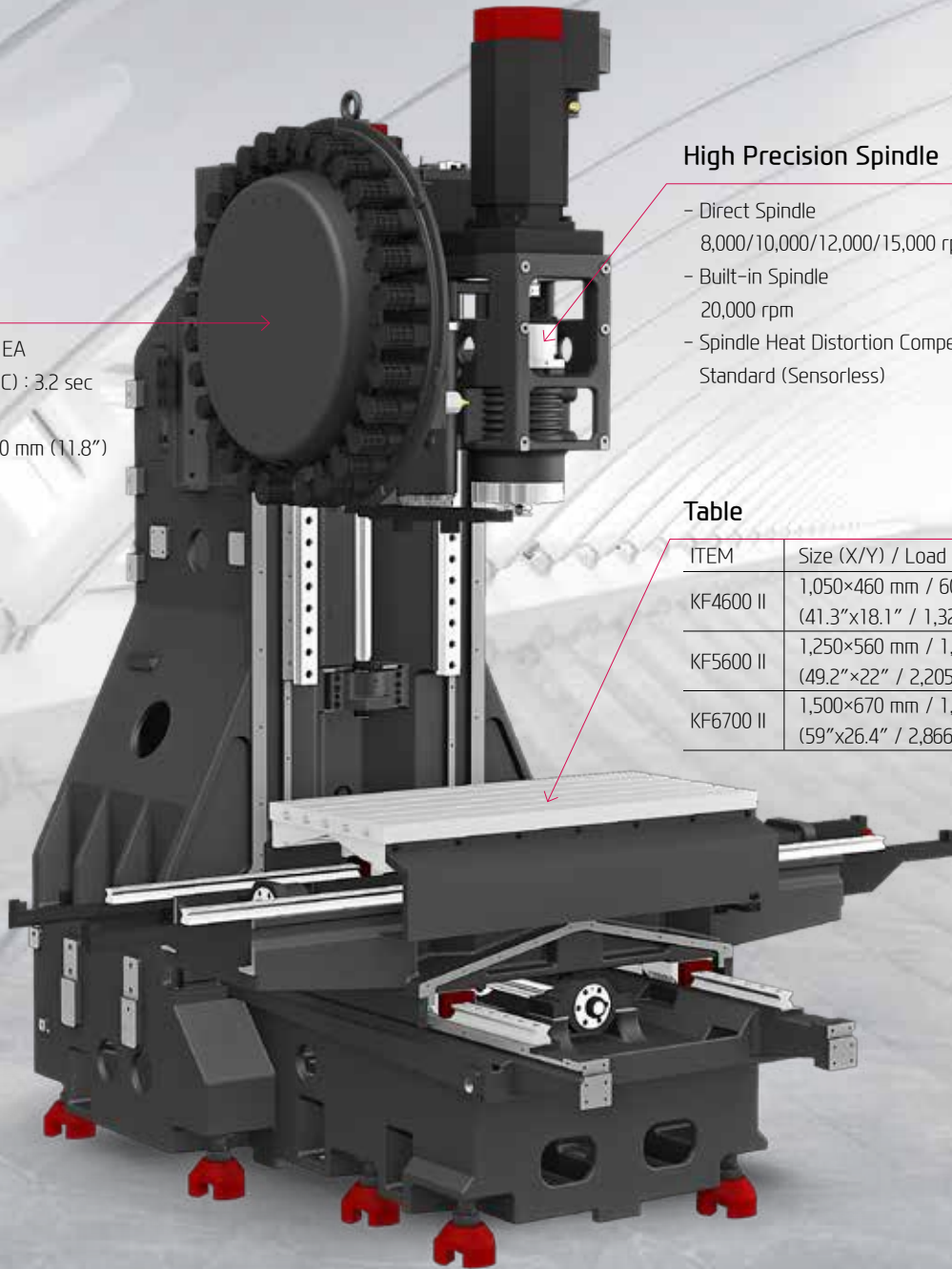

HIGH-PRECISION, SPEED & LARGE WORKING AREA

HIGH-PRECISION STRUCTURE

Optimal Structural Analysis

KF-II Series is designed to have optimal structure through Hyundai WIA's unique structural analysis.

In particular, enhancement of bed and column's rigidity makes excellent performance even in heavy duty cutting.

One Piece High Column (Direct Sp.)

One piece high column is provided as an option up to z-axis height. This option helps to process bigger products such as rack housing.

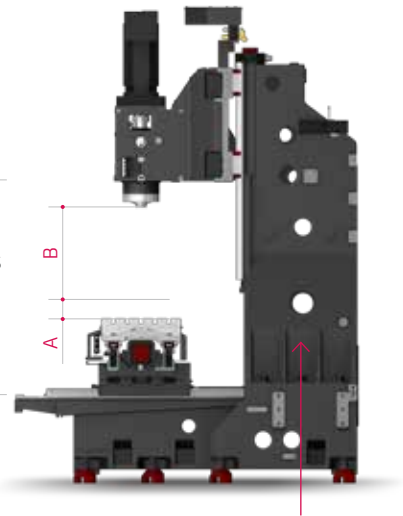

Incomparably Strong Rigidity Compared to the Block-type High Column

KF4600 II (A~B)	KF4600 II High Column (A~B) OPTION
150~670 mm	350~870 m/min
KF5600 II (A~B)	KF5600 II High Column (A~B) OPTION
150~670 [785] mm	450~1,085 m/min
KF6700 II (A~B)	KF6700 II High Column (A~B) OPTION
150~785 mm	450~1,085 m/min

INCREASE OF SADDLE RIGIDITY

The KF6700 with the largest saddle among the KF-II series has almost same level of saddle-end displacement as the base model.

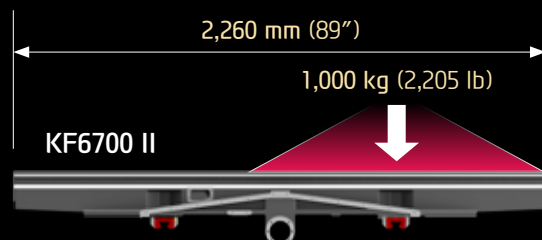

02 HIGH-SPEED FEED

Highest Quality, High-speed Vertical Machining Center

Travel (X/Y/Z)

KF4600 II

900/460/520 mm

(35.4"/18.1"/20.5")

KF5600 II

[] : Option

1,100/560/520 [635] mm

(43.3"/22"/20.5" [25"])

KF6700 II

1,300/670/635 mm

(51.2"/26.4"/25")

Rapid Traverse Rate (X/Y/Z)

KF4600 II

36/36/30 m/min

(1,417/1,417/1,181 ipm)

KF5600 II

36/36/30 m/min

(1,417/1,417/1,181 ipm)

KF6700 II

36/36/30 m/min

(1,417/1,417/1,181 ipm)

❖ KF5600 II / KF6700 II High performance motor - Rapid Traverse Rate : 42/42/36 m/min (1,654/1,654/1,417 ipm)

REDUCED NON-CUTTING TIME & IMPROVED FEED PRECISION

GUIDE WAY

High-Speed Roller LM Guideway

Linear roller guideways are applied to reduce non-cutting time and bring high rigidity. Each axis is directly connected to a highly reliable digital servo motor to provide high rigidity and minimal thermal displacement.

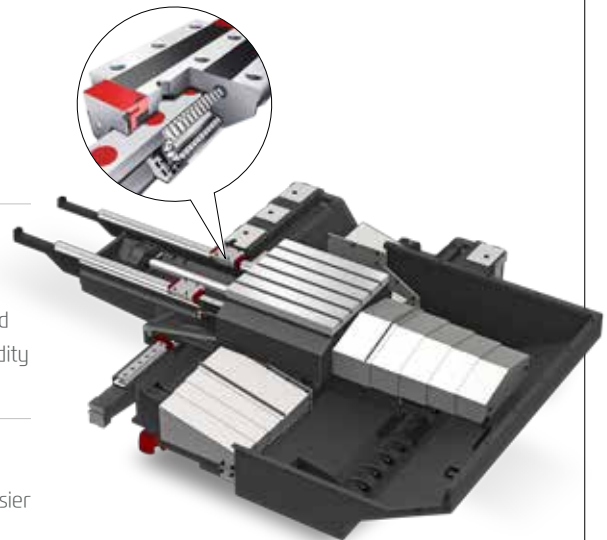

Improvement in Slide Cover

The increased slope of slide cover makes chip disposal easier and minimizes slide cover breakage.

Double Anchored Ball Screw

The pretensioned ball screw minimizes the expansion and contraction according to the heat and further reinforces the rigidity by the double anchor support method.

In addition, the coupling of the ballscrews and the highly reliable digital servo motors are connected by **metal plate couplings**, to reduce coupling breakage and backlash.

3 Row bearing + Oil Lubricated
Rigidity 147% Increase
compared to previous model

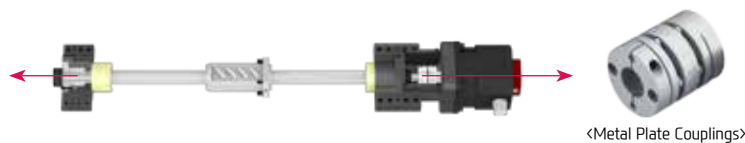

Increase in Durability of Z-axis ball screw

Lifetime of the bearing has been greatly increased by optimizing the spindle structure and lubrication method.

※ Customer Actual Data



NUT COOLING BALL SCREW

OPTION

Nut cooling ball screws on all axes decrease thermal displacement which enhances precision machining ability.



03 HIGH PRECISION SPINDLE

Excellent machining performance with high-precision spindle

Spindle Specifications

ITEM	Speed r/min	Motor (Max./Cont.)	Torque (Max./Cont.)	Type
HYUNDAI WIA FANUC SMART PLUS	8,000/10,000 rpm	18.5/11 kW (25/15 HP)	118/52.5 N·m	Direct
	8,000 rpm (KF6700 II)	18.5/15 kW (25/20 HP)	118/71.6 N·m	
	8,000 rpm (High-torque)	15/11 kW (25/15 HP)	286/143 N·m	
	12,000 rpm	18.5/11 kW (25/15 HP)	118/52.5 N·m	
	15,000 rpm	18.5/11 kW (25/15 HP)	118/52.5 N·m	
HYUNDAI-ITROL	12,000 rpm	16.2/8.5 kW (21.7/11.4 HP)	119.7/63 N·m	Built-in
HEIDENHAIN	12,000 rpm	17/10 kW (22.8/13.4 HP)	108.6/63.7 N·m	
FANUC 31i-B	20,000 rpm	22/18.5 kW (29.5/25 HP)	98/80 N·m	

HIGH-PERFORMANCE, HIGH-PRECISION SPINDLE

SPINDLE

Direct Driven Spindle

The directly coupled spindle at a maximum revolution of 15,000rpm, allows high-speed processing. Additionally, the large diameter and the thickness of the spindle add to the stability of the machine.



Direct Driven Spindle

Built-in Spindle

The 20,000rpm built-in spindle can minimize vibration transmitted to the spindle. It allows excellent machining performance in mold and high-precision products.



Built-in Spindle

Spindle Cooling (Over 10,000 rpm Std.)

The spindle cooling system minimizes thermal displacement which can happen during lengthy machining operations, and offers continued accuracy based on the thermal stability.

❖ Improved cooling capability with chilling through head frame

Through Spindle Coolant (20/30/70 bar) **OPTION**

Through Spindle Coolant is exceedingly useful when drilling deep holes. It helps increase the lifetime of the tool, while decreasing cycle time.

The improved quality of rotary joint prevents oil leakage.

Dual Contact Spindle

The Big Plus spindle system (BBT40) provides dual contact between the spindle face and the flange face of the tool holder.

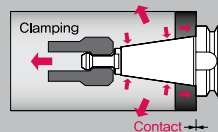

❖ Hybrid Tool Lock : Reducing heat and noise by removing the hydraulic motor

HSK TOOL HOLDER

OPTION

HSK tool holder is utilized for precise positioning with less expansion in the spindle taper during high speed rotation. This ensures an excellent level of precision for die mold machining.



HSK-A63

04 ATC & MAGAZINE

High Productivity Achieved with High Rigidity, Accuracy Machining

No. of Tools

30 [40]_{EA}

Tool Selection Method

Random [Fixed]

Max. Tool Length

300_{mm} (11.8")

Max. Tool Weight

8_{kg} (18 lb)

Tool Shank

BBT40 [12K, 15K, 20K : HSK-A63]

Max. Tool Dia. (W.T/W.O)

30T : Ø80 [40T : Ø76]/Ø125_{mm} (30T : Ø3.1" [40T : Ø3"]/Ø4.9")

[] : Option

HIGH RIGIDITY, TOOL CHANGE SYSTEM

ATC & MAGAZINE

High Speed ATC

Position control through twin arm ATC on servo motors has been improved drastically. In addition, tool exchanging has become easier, reducing specific cutting time tremendously.

Position control on the Twin Arm ATC has improved drastically. The twin arm ATC enables faster tool change and increased productivity.



Tool Change Time (C-C)

KF4600I : 3.2 sec KF5600II : 3.2 [Z-axis 635mm (25") : 3.5] sec KF6700II : 3.5 sec

[] : Option

Magazine

The tool magazine holds **30 tools** as standard and **40 tools** as an option. Due to the wider selection of tools and the random tool selection method, tool change time has improved.

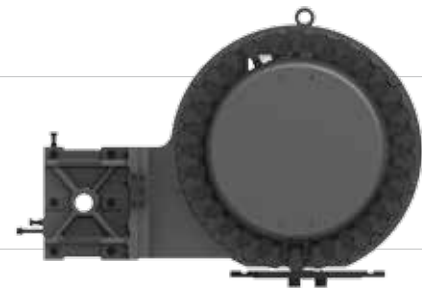

[Fixed : Option]



05 USER CONVENIENCE

Various Devices for User Friendly

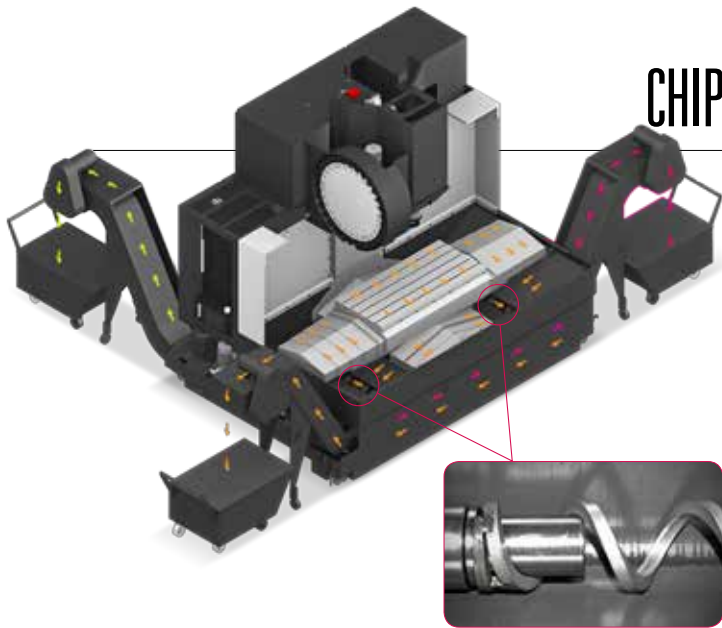

CHIP DISPOSAL SOLUTION & COOLANT UNIT



Spindle Nozzle & Cutting Air Blow



Bed Flushing Coolant (Opt.)



Gun Coolant (Opt.)



Air Gun (Opt.)

Interior Screw Chip Conveyor (Forward / Backward Rotation Function)

Dual screw type chip conveyors are located at each side of the bed which makes it convenient to remove chips. The interior screw and the chip conveyor operate at the same time and can be controlled separately at the time of prior consultation.

(Three screws for rear-type conveyor: 2 sides + 1 front)

Furthermore, chip disposal capability significantly has been improved due to optional bed-flushing coolant.

Upper-type Conveyor (Std.)

The upper type chip conveyor is applied as a standard to efficiently remove chips generated during machining. In addition, the 365 liter (KF5600II, 6700II) of large coolant tank provides a seamless machining environment even with large amounts of coolant.

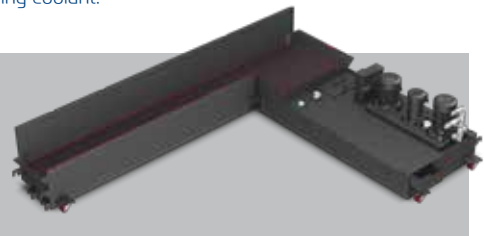

Hinge	Chip Type : Roughing Chip, Long Chip, Chip complex	Material : SS41, 45C, Cast Steel	Side/Rear Direction
	Highly efficient when disposing a lot of chips. Capable of handling stringy chips..		
Scraper	Chip Type : Finely broken chip blown out	Material : cast Iron, Nonferrous	
	Convenient for shortly cut chips.		
❖ Screw	Chip Type : The lower portion of micro-chips	Material : Steel, Casting	
	Compresses and ejects chips to reduce chip Trouble.		
❖ Drum Filter	Chip Type : Powder, Micro Chip	Material : AL	
	Advantageous in precision, as the chips do not flow in to the coolant nozzle.		

❖ When ordering a screw or drum filter chip conveyor, prior consult with hyundai wia's sales person.

Optional

PRECISION SYSTEM



Linear Scale

Linear scales increase positioning accuracy and reduce distortion caused by thermal growth, thus ensuring a more accurate finished part



Touch Sensor

Workpiece coordinate values can be set automatically using the optional spindle probe.



TLM (Laser & Touch)

Tool lengths and diameters can be set automatically using the optional tool setter. This can also be used to monitor attrition and detect broken tools.

ECO SYSTEM



Oil-skimmer

Separated oil-skimmer and coolant tank to keep coolant free of tramp oils.



Automatic Grease Supply Unit

Optional automatic grease lubrication eliminates the need for an oil skimmer and significantly reduces maintenance costs against oil lubrication.



MQL (Minimal Quantity Lubrication)

The goal of this system is to spray only the amount of lubricant required to prevent heat and chip build up at the cutting tool or work piece face.



NC ROTARY TABLE & HYDRAULIC SUPPLY UNIT

Various shapes of products can be processed when using NC Rotary Table. In addition, 100 bar of high pressure hydraulic unit for the fixture increases the tightening power of the teeth.

06 HYUNDAI WIA FANUC – SMART PLUS

The Compatible All-round Control



15" Touch-type Monitor as a standard

Smart Machine Control	Fast Cycle Time Technology
Conversational Program	Fine Surface Technology
i-HMI	SmartGuide-i
AI Contour Control	Machining-aid Function
Smooth Tolerance Control	AICC-2 (200 blocks)
JERK Control	0.1µm command and specify tolerance
Machining Condition Selection	Diminished vibration by controlling acceleration speed
Machining Quality Control Function	Designated machining level based on speed & quality
Part Program Storage	Smooth Tolerance+ integrated support
No. of Registerable Programs	5120M (2MB)
	1000 EA



Energy Saving & ECO System



SUPPORTS SHORTCUTS

The energy-saving mode and optimization function can be used right away.

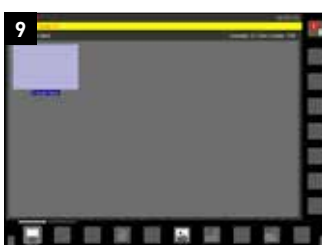
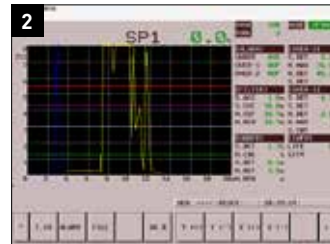

SMART SOFTWARE

1. Dialogue Program (Smart Guide-i)

This software offers maximum user convenience through a dialogue program from setup to machining. This includes writing machining programs and simulation checks.

2. Tool Monitoring (HW-TM) Adaptive Feed Control (HW-AFC)

- HW-TM : This tool status monitoring software monitors and protects workpiece, tools, and equipment through real-time monitoring of the motor load from machining.
- HW-AFC : This software improves the lifetime and productivity of tools by automatically controlling the feed to maintain an even machining load.

3. Thermal Displacement Compensation of Spindle (HW-TDC)

This software improves machining precision by minimizing thermal deformation from changes in external environments and machining.

4. Machine Guidance (HW-MCG)

This software offers various user convenience functions such as tool manipulation, maintenance, tool monitoring, and a pop-up/status window

5. Tool/Workpiece Measurement (Renishaw GUI)

This user convenience GUI software measures material coordinate systems, tool lengths/diameters/damage to tools (included in Renishaw H/W set)

6. Machining Condition Selection (HW-MCS)

This software automatically optimizes rapid transfer parameters for cutting transfers and workpiece weights depending on the machining type (based on rate/precision /quality)

7. Manual Viewer

This software enables users to view electronic manuals right from the tool (Only in iHMI tools)

8. Premium tool Operation

This software offers premium graphic functions for more intuitive tools operation (Only in iHMI tools)

9. Operation Memo

This software is capable of managing customer notes such as tool information and issues (Only in iHMI tools)

10. Scheduling

This software enables viewing/setting up directly from the tool. This allows such actions as managing customer's tool schedules and schedule notification (Only in iHMI tools)

SPECIFICATIONS

Spindle Output/Torque Diagram

Direct 8,000rpm (KF4600II/5600II)

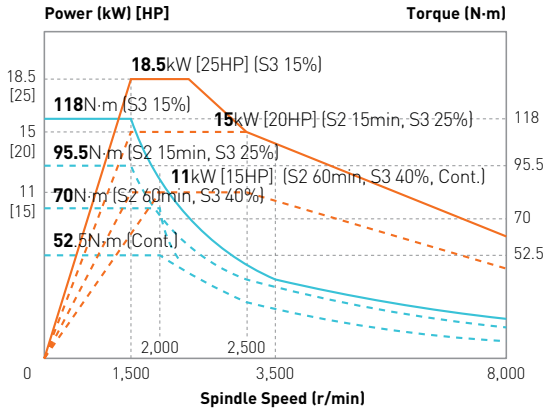

Direct 8,000rpm (KF6700II)

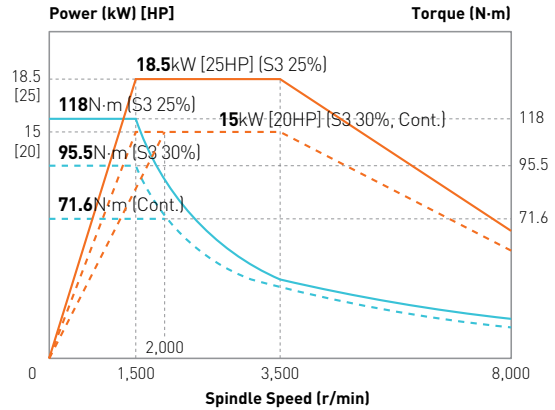

Direct 8,000rpm (High-Torque)

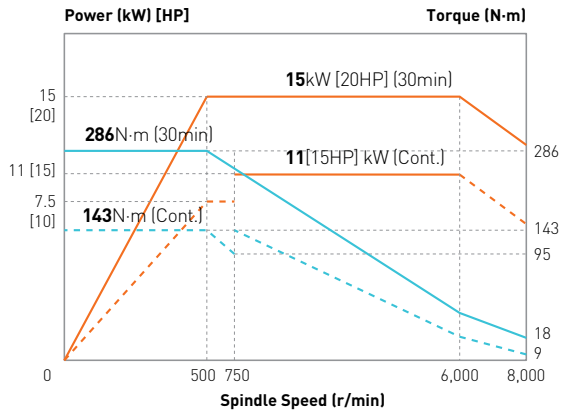

Direct 10,000rpm

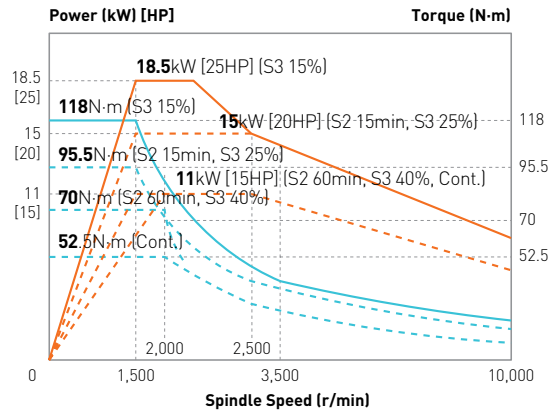

Direct 12,000rpm

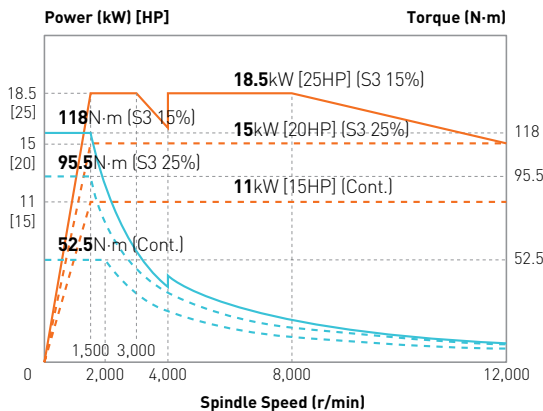

Direct 15,000rpm

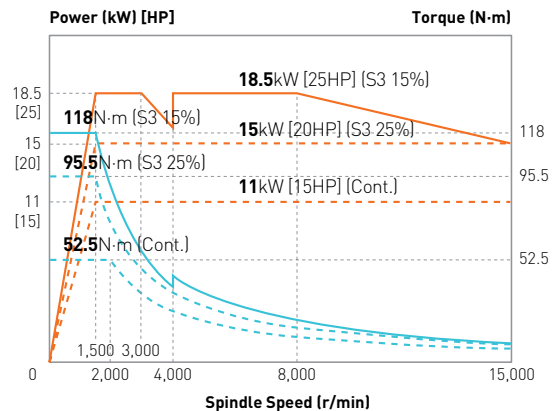

SPECIFICATIONS

Spindle Output/Torque Diagram

iTROL Direct 12,000rpm

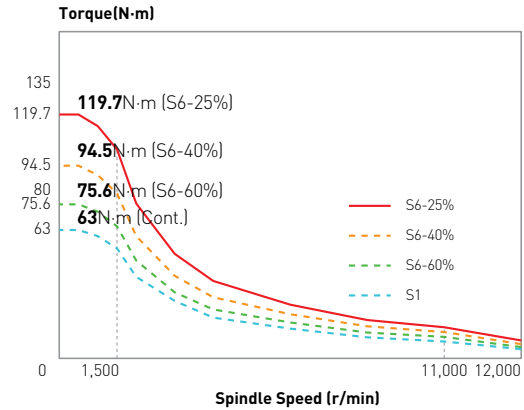
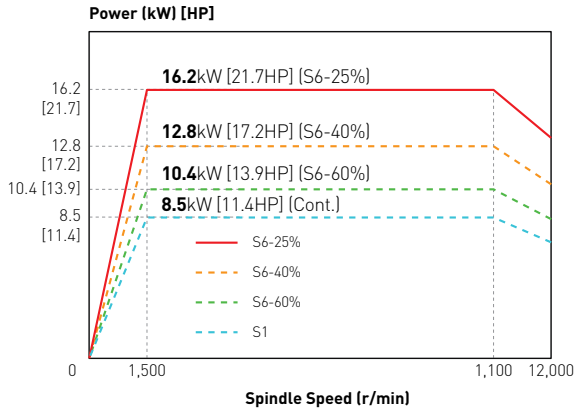

HEIDENHAIN Direct 12,000rpm

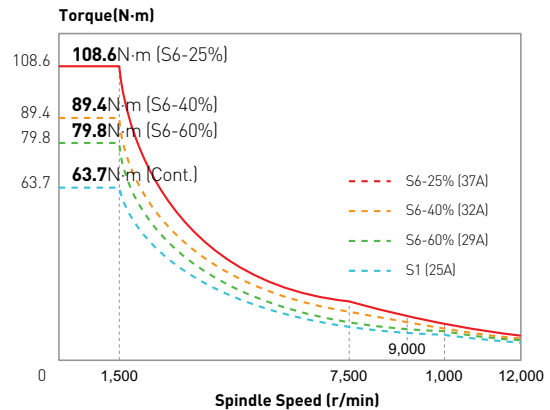
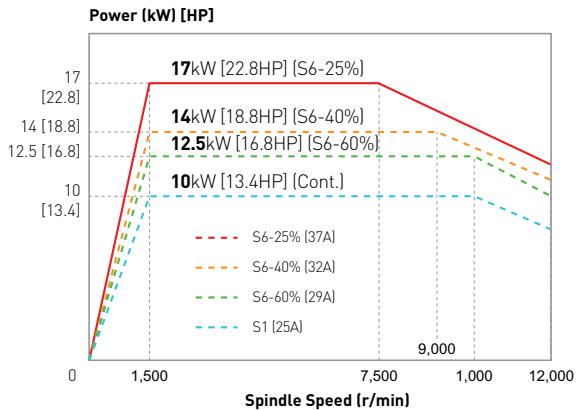

Built-in 20,000rpm

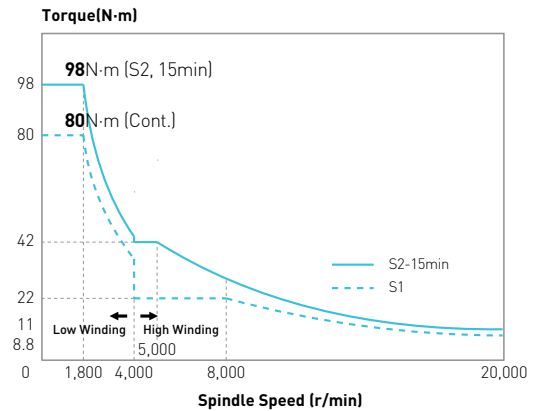
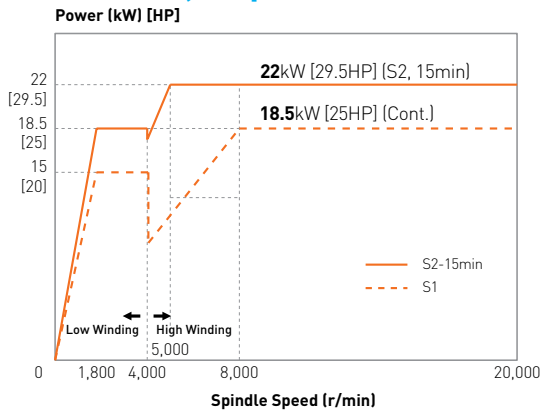

SPECIFICATIONS

Standard & Optional

● : Standard ○ : Option ☆ : Prior Consultation - : Non Applicable

Spindle		KF4600 II
8,000rpm	FANUC	●
8,000rpm (High-torque)	FANUC	○
10,000rpm	FANUC	○
12,000rpm	FANUC	○
15,000rpm	FANUC	○
12,000rpm	I-TROL	○
12,000rpm	HEIDENHAIN	○
Spindle Cooling System	8,000rpm	○
	Over 10,000rpm	●
ATC		
ATC Extension	30	●
	40	○
Tool Shank Type	BBT40	●
	HSK-A63 (12K, 15K)	○
	CAT40/BCV40	○
U-Center	D'andrea	○
Pull Stud	45°	●
Table & Column		
T-Slot Table		●
NCRotary Table		☆
High Column (Direct Sp.)	200mm (7.9")	○ (15K -)
	300mm (11.8")	-
Coolant System		
Std. Coolant (Main Spindle Nozzle)		●
Through Spindle Coolant	20bar (290 psi)	○
	30bar (435 psi), 20 ℓ (5.3 gal)	○
	70bar (1,015 psi), 15 ℓ (4 gal)	○
	70bar (1,015 psi), 30 ℓ (7.9 gal)	○
Top Cover		●
Shower Coolant		○
Gun Coolant		○
Bed Flushing Coolant		○
Air Gun		○
Cutting Air Blow		○
Tool Measuring Air Blow (Only for TLM)		●
Air Blow for Automation		☆
Thru MQL Device (Without MQL)		☆
Coolant Chiller (Sub Tank)		☆
Power Coolant System (For Automation)		☆
Chip Disposal		
Coolant Tank	340 ℓ (89.8 gal)	●
	365 ℓ (96.4 gal)	-
Interior Screw Chip Conveyor		●
Upper Chip Conveyor (Hinge)	Left	○
	Right	○
Flood Chip Conveyor (Hinge/Scraper)	Left	○
	Right	○
	Rear	○
Screw Type Chip Conveyor	Left	☆
	Right	☆
Drum Filter Type Chip Conveyor	Left	☆
	Right	☆
	Rear	☆
Chip Wagon	Standard (180 ℓ [47.5 gal])	○
	Swing (200 ℓ [52.8 gal])	○
	Large Swing (290 ℓ [76.6 gal])	○
	Large Size (330 ℓ [87.2 gal])	○
	Customized	☆

S/W		KF4600 II
Machine Guidance (HW-MCG)		●
Tool Monitoring (HW-TM) : FANUC/ITROL		○/●
DNC Software (HW-eDNC)		○
Spindle Heat Distortion Compensation (HW-TDC)		○
Spindle Warm up Function (HW-WARMUP)		●
Energy Saving System (HW-ESS)		●
Machine Monitoring System (HW-MMS)		○
RENISHAW GUI		○
Machining Condition Selection (HW-MCS)		●
Adaptive Feed Control (HW-AFC)		●
Conversational Program	Smart Guide-i	●
	HW-DPRO	○
Electric Device		
Call Light	1 Color : ●	●
Call Light	2 Color : ● ●	○
Call Light	3 Color : ● ● ●	○
Call Light & Buzzer	3 Color : ● ● ● B	○
Electric Cabinet Light		○
Remote MPG		●
3 Axis MPG		○
Work Counter	Digital	○
Total Counter	Digital	○
Tool Counter	Digital	○
Multi Tool Counter	Digital	○
Electric Circuit Breaker		○
AVR (Auto Voltage Regulator)		☆
Transformer	30kVA (Direct)	○
	35kVA (Built-in)	-
AVR (Auto Voltage Regulator)		○
Back up Module for Black out		○
Measuring Device		
Air Zero	TACO	○
	SMC	○
Work Measuring Device		○
TLM	Touch	○
(Marposs/Renishaw/Blum)	Laser	○
Tool Broken Detecting Device		☆
Linear Scale	X/Y/Z Axis	○
Coolant Level Sensor (Only for Chip Conveyor, Bladder Type)		☆
Environment		
Air Conditioner		○
Oil Mist Collector		☆
Oil Skimmer (Only for Chip Conveyor)		○
MQL (Minimal Quantity Lubrication)		☆
Fixture & Automation		
Auto Door	Std.	○
	High Speed	☆
Auto Shutter (Only for Automatic System)		○
Sub O/P		☆
NC Rotary Table/F	Single	○
	Channel	☆
Control of Additional Axis	1Axis	○
	2Axis	☆
External M Code 4ea		○
Automation Interface		☆
I/O Extension (In & Out)	16 Contact	○
	32 Contact	○
Hyd. Device		
Std. Hyd. Unit	45bar (653 psi)	-
	70bar (1,015 psi)	○
	100bar (1,450 psi)	○
	Customized	☆
ETC		
Tool Box		●
Customized Color	Need for Munsel No.	☆
CAD&CAM Software		☆

SPECIFICATIONS

Standard & Optional

● : Standard ○ : Option ☆ : Prior Consultation - : Non Applicable

Spindle		KF5600 II
8,000rpm	FANUC	●
8,000rpm (High-torque)	FANUC	○
10,000rpm	FANUC	○
12,000rpm	FANUC	○
15,000rpm	FANUC	○
20,000rpm (Built-in)	FANUC	○
12,000rpm	I-TROL	○
12,000rpm	HEIDENHAIN	○
Spindle Cooling System	8,000rpm	○
	Over 10,000rpm	●
ATC		
ATC Extension	30	●
	40	○
Tool Shank Type	BBT40	●
	HSK-A63 (12K, 15K)	○
	CAT40/BCV40	○
U-Center	D'andrea	○
Pull Stud	45°	●
Table & Column		
T-Slot Table		●
NC Rotary Table		☆
High Column (Direct Sp.)	200mm (7.9")	-
	300mm (11.8")	○
Coolant System		
Std. Coolant (Main Spindle Nozzle)		●
	20bar (290 psi)	○
	30bar (435 psi), 20 ℓ (5.3 gal)	○
Through Spindle Coolant	70bar (1,015 psi), 15 ℓ (4 gal)	○
	70bar (1,015 psi), 30 ℓ (7.9 gal)	○
Top Cover		●
Shower Coolant		○
Gun Coolant		○
Bed Flushing Coolant		○
Air Gun		○
Cutting Air Blow		○ (20K ●)
Tool Measuring Air Blow (Only for TLM)		●
Air Blow for Automation		☆
Thru MQL Device (Without MQL)		☆
Coolant Chiller (Sub Tank)		☆
Power Coolant System (For Automation)		☆
Chip Disposal		
Coolant Tank	340 ℓ (89.8 gal)	-
	365 ℓ (96.4 gal)	●
Interior Screw Chip Conveyor		●
Upper Chip Conveyor (Hinge)	Left	○
	Right	○
Flood Chip Conveyor (Hinge/Scraper)	Left	○
	Right	○
	Rear	○
Screw Type Chip Conveyor	Left	☆
	Right	☆
Drum Filter Type Chip Conveyor	Left	☆
	Right	☆
	Rear	☆
Chip Wagon	Standard (180 ℓ [47.5 gal])	○
	Swing (200 ℓ [52.8 gal])	○
	Large Swing (290 ℓ [76.6 gal])	○
	Large Size (330 ℓ [87.2 gal])	○
	Customized	☆

S/W		KF5600 II
Machine Guidance (HW-MCG)		●
Tool Monitoring (HW-TM) : FANUC/iTROL		○/●
DNF Software (HW-eDNC)		○
Spindle Heat Distortion Compensation (HW-TDC)		○ (20K ●)
Spindle Warm up Function (HW-WARMUP)		●
Energy Saving System (HW-ESS)		●
Machine Monitoring System (HW-MMS)		○
RENISHAW GUI		○ (20K ●)
Machining Condition Selection (HW-MCS)		●
Adaptive Feed Control (HW-AFC)		●
Conversational Program	Smart Guide-i	● (FANUC 31i-B ○)
	HW-DPRO	○
Electric Device		
Call Light	1 Color : ●	●
Call Light	2 Color : ●●	○
Call Light	3 Color : ●●●	○
Call Light & Buzzer	3 Color : ●●● B	○
Electric Cabinet Light		○
Remote MPG		●
3 Axis MPG		○
Work Counter	Digital	○
Total Counter	Digital	○
Tool Counter	Digital	○
Multi Tool Counter	Digital	○
Electric Circuit Breaker		○
AVR (Auto Voltage Regulator)		☆
Transformer	30kVA (Direct)	○
	35kVA (Built-in)	○
AVR (Auto Voltage Regulator)		○ (20K ●)
Back up Module for Black out		○
Measuring Device		
Air Zero	TACO	○
	SMC	○
Work Measuring Device		○
TLM	Touch	○ (20K ●)
(Marposs/Renishaw/Blum)	Laser	○
Tool Broken Detective Device		☆
Linear Scale	X/Y/Z Axis	○
Coolant Level Sensor (Only for Chip Conveyor, Bladder Type)		☆
Environment		
Air Conditioner		○
Oil Mist Collector		☆
Oil Skimmer (Only for Chip Conveyor)		○
MQL (Minimal Quantity Lubrication)		☆
Fixture & Automation		
Auto Door	Std.	○
	High Speed	☆
Auto Shutter (Only for Automatic System)		○
Sub O/P		☆
NC Rotary Table/F	Single	○
	Channel	☆
Control of Additional Axis	1Axis	○
	2Axis	☆
External M Code 4ea		○
Automation Interface		☆
I/O Extension (In & Out)	16 Contact	○
	32 Contact	○
Hyd. Device		
Std. Hyd. Unit	45bar (653 psi)	-
	70bar (1,015 psi)	○
	100bar (1,450 psi)	○
	Customized	☆
ETC		
Tool Box		●
Customized Color	Need for Munsel No.	☆
CAD&CAM Software		☆

Specifications are subject to change without notice for improvement.

SPECIFICATIONS

Standard & Optional

● : Standard ○ : Option ☆ : Prior Consultation - : Non Applicable

Spindle		KF6700 II
8,000rpm	FANUC	●
8,000rpm (High-torque)	FANUC	○
10,000rpm	FANUC	○
12,000rpm	FANUC	○
15,000rpm	FANUC	○
20,000rpm (Built-in)	FANUC	○
12,000rpm	I-TROL	○
12,000rpm	HEIDENHAIN	○
Spindle Cooling System	8,000rpm	○
	Over 10,000rpm	●
ATC		
ATC Extension	30	●
	40	○
Tool Shank Type	BBT40	●
	HSK-A63 (12K, 15K)	○
	CAT40/BCV40	○
U-Center	D'andrea	○
Pull Stud	45°	●
Table & Column		
T-Slot Table		●
NCRotary Table		☆
High Column (Direct Sp.)	200mm (7.9")	-
	300mm (11.8")	○
Coolant System		
Std. Coolant (Main Spindle Nozzle)		●
Through Spindle Coolant	20bar (290 psi)	○
	30bar (435 psi), 20 ℓ (5.3 gal)	○
	70bar (1,015 psi), 15 ℓ (4 gal)	○
	70bar (1,015 psi), 30 ℓ (7.9 gal)	○
Top Cover		●
Shower Coolant		○
Gun Coolant		○
Bed Flushing Coolant		○
Air Gun		○
Cutting Air Blow		○ (20K ●)
Tool Measuring Air Blow (Only for TLM)		●
Air Blow for Automation		☆
Thru MQL Device (Without MQL)		☆
Coolant Chiller (Sub Tank)		☆
Power Coolant System (For Automation)		☆
Chip Disposal		
Coolant Tank	340 ℓ (89.8 gal)	-
	365 ℓ (96.4 gal)	●
Interior Screw Chip Conveyor		●
Upper Chip Conveyor (Hinge)	Left	○
	Right	○
Flood Chip Conveyor (Hinge/Scraper)	Left	○
	Right	○
	Rear	○
Screw Type Chip Conveyor	Left	☆
	Right	☆
Drum Filter Type Chip Conveyor	Left	☆
	Right	☆
	Rear	☆
Chip Wagon	Standard (180 ℓ [47.5 gal])	○
	Swing (200 ℓ [52.8 gal])	○
	Large Swing (290 ℓ [76.6 gal])	○
	Large Size (330 ℓ [87.2 gal])	○
	Customized	☆

S/W		KF6700 II
Machine Guidance (HW-MCG)		●
Tool Monitoring (HW-TM) : FANUC/ITROL		○/●
DNC Software (HW-eDNC)		○
Spindle Heat Distortion Compensation (HW-TDC)		○ (20K ●)
Spindle Warm up Function (HW-WARMUP)		●
Energy Saving System (HW-ESS)		●
Machine Monitoring System (HW-MMS)		○
RENISHAW GUI		○ (20K ●)
Machining Condition Selection (HW-MCS)		●
Adaptive Feed Control (HW-AFC)		●
Conversational Program	Smart Guide-i	● (FANUC 31i-B ○)
	HW-DPRO	○
Electric Device		
Call Light	1 Color : ●	●
	2 Color : ● ●	○
	3 Color : ● ● ●	○
Call Light & Buzzer	3 Color : ● ● ● B	○
Electric Cabinet Light		○
Remote MPG		●
3 Axis MPG		○
Work Counter	Digital	○
Total Counter	Digital	○
Tool Counter	Digital	○
Multi Tool Counter	Digital	○
Electric Circuit Breaker		○
AVR (Auto Voltage Regulator)		☆
Transformer	30kVA (Direct)	○
	35kVA (Built-in)	○
AVR (Auto Voltage Regulator)		○ (20K ●)
Back up Module for Black out		○
Measuring Device		
Air Zero	TACO	○
	SMC	○
Work Measuring Device		
TLM (Marposs/Renishaw/Blum)	Touch	○ (20K ●)
	Laser	○
Tool Broken Detective Device		☆
Linear Scale	X/Y/Z Axis	○
Coolant Level Sensor (Only for Chip Conveyor, Bladder Type)		☆
Environment		
Air Conditioner		○
Oil Mist Collector		☆
Oil Skimmer (Only for Chip Conveyor)		○
MQL (Minimal Quantity Lubrication)		☆
Fixture & Automation		
Auto Door	Std.	○
	High Speed	☆
Auto Shutter (Only for Automatic System)		○
Sub O/P		☆
NC Rotary Table/F	Single	○
	Channel	☆
Control of Additional Axis	1Axis	○
	2Axis	☆
External M Code 4ea		○
Automation Interface		☆
I/O Extension (In & Out)	16 Contact	○
	32 Contact	○
Hyd. Device		
Std. Hyd. Unit	45bar (653 psi)	-
	70bar (1,015 psi)	○
	100bar (1,450 psi)	○
	Customized	☆
ETC		
Tool Box		●
Customized Color	Need for Munsel No.	☆
CAD&CAM Software		☆

SPECIFICATIONS

External Dimensions

unit : mm(in)

KF4600 II

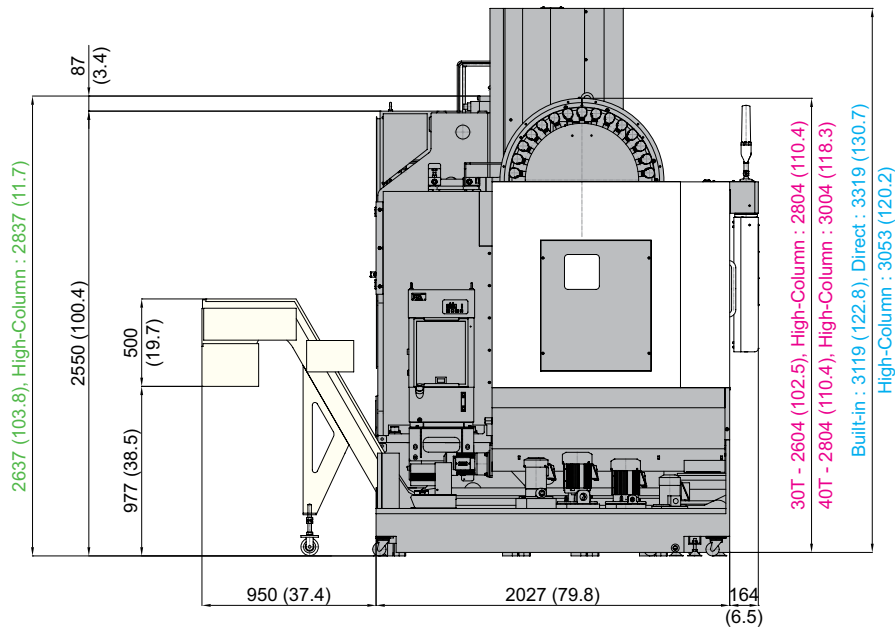
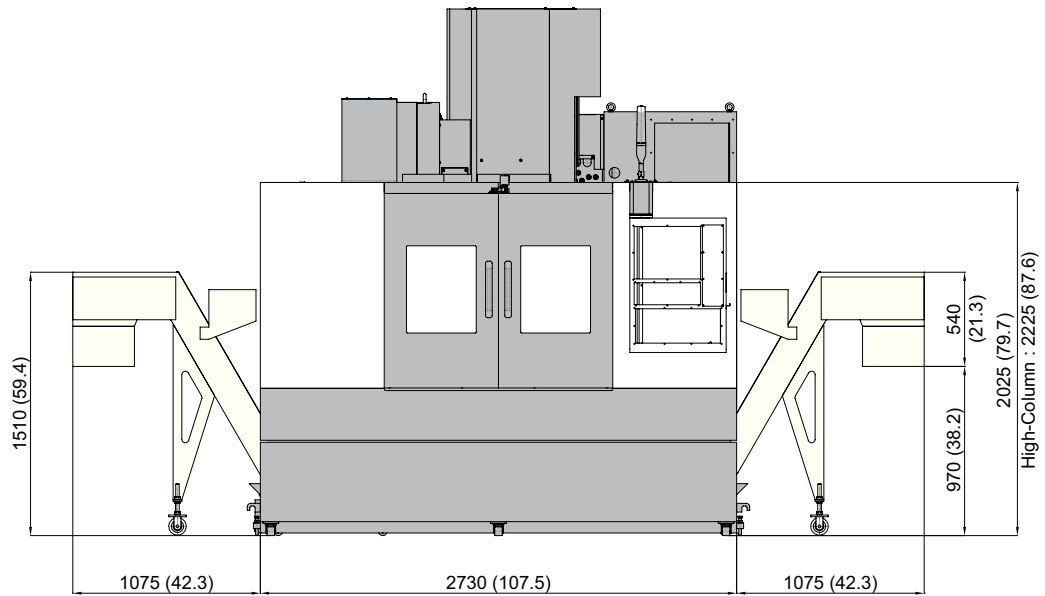

※ Requires 120mm level block when using rear-top conveyor

■ : Max. height | ■ : Height to ATC cover | ■ : Height to Z-axis motor

SPECIFICATIONS

External Dimensions

unit : mm(in)

KF5600 II

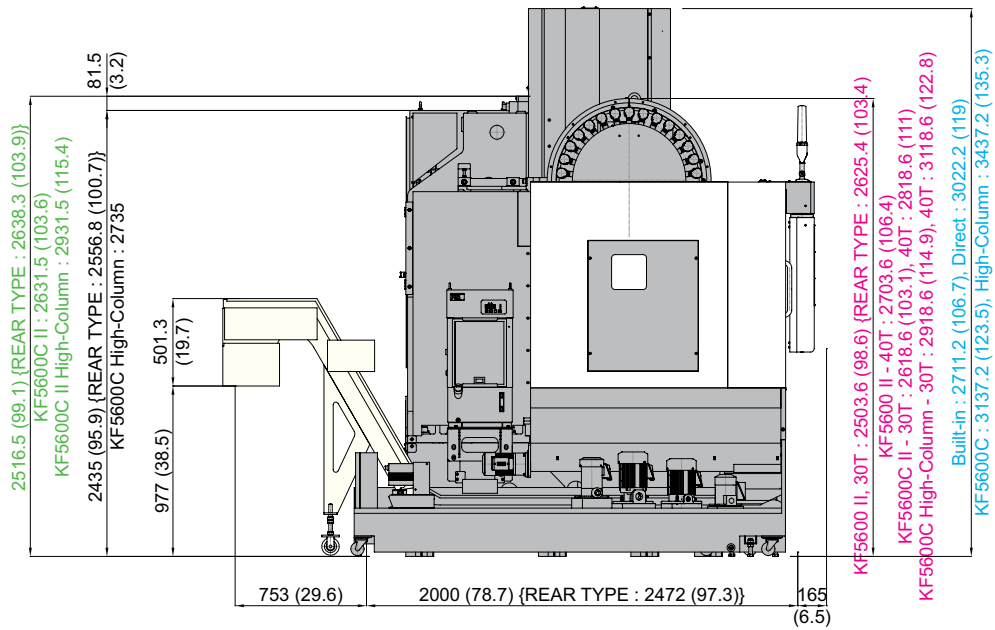
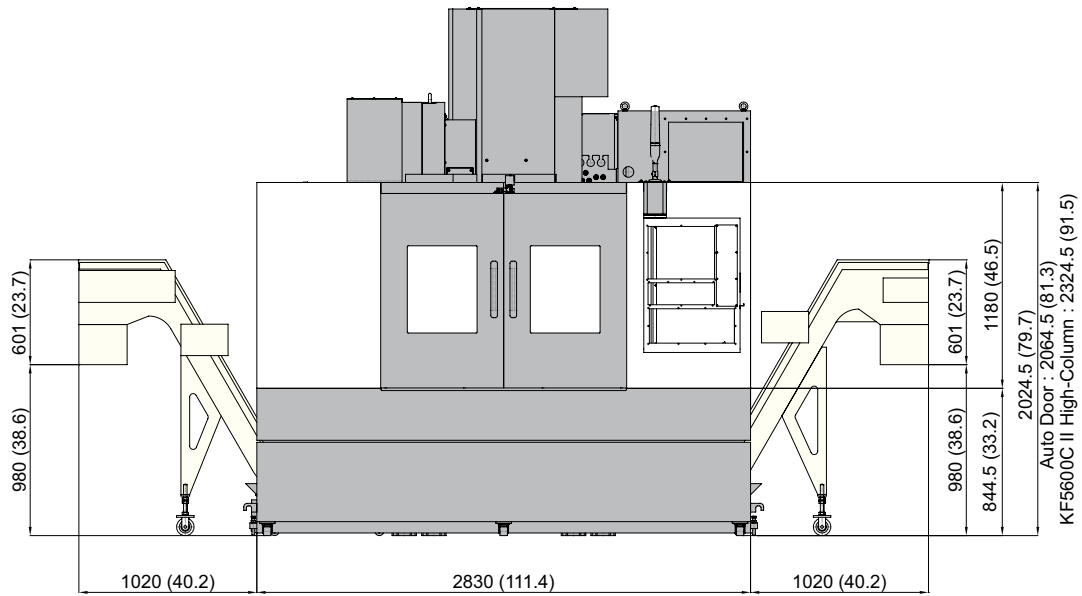

※ Requires 120mm level block when using rear-top conveyor

■ : Max. height | ■ : Height to ATC cover | ■ : Height to Z-axis motor

SPECIFICATIONS

External Dimensions

unit : mm(in)

KF6700 II

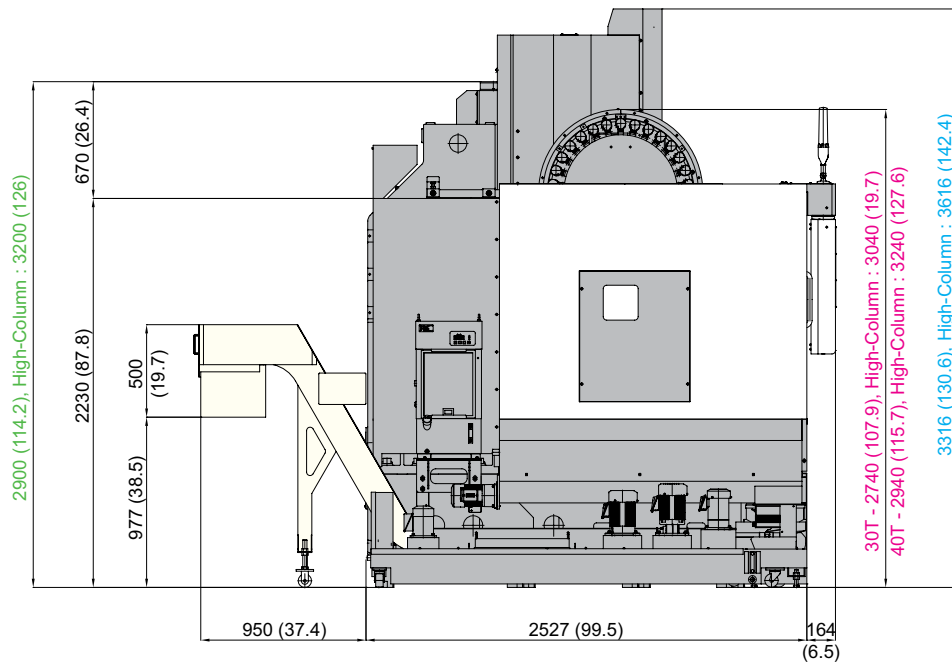
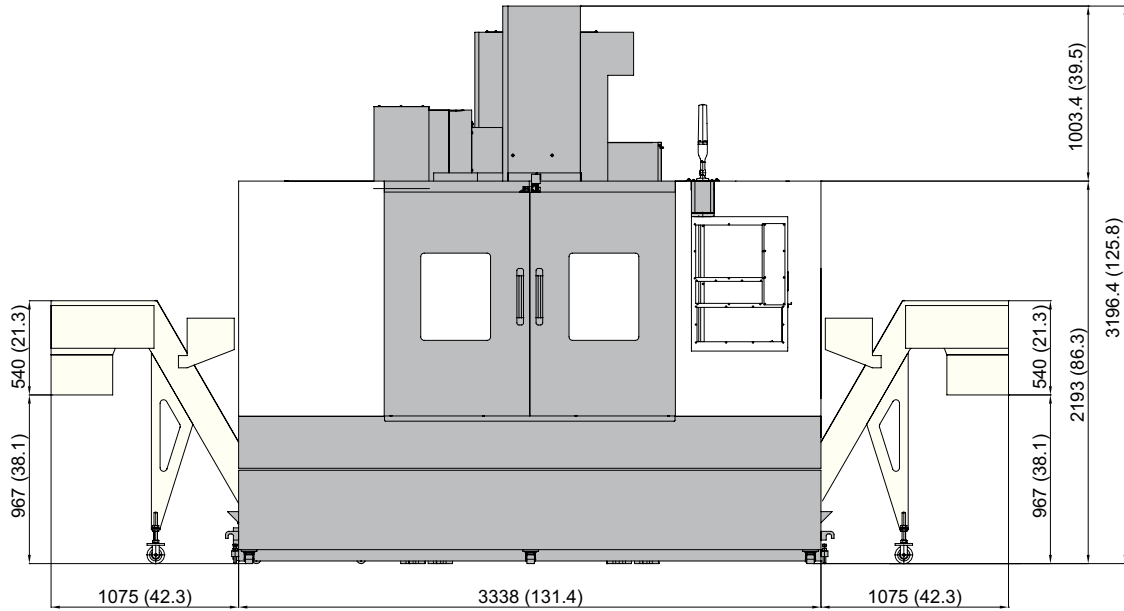

※ Requires 120mm level block when using rear-top conveyor

■ : Max. height | ■ : Height to ATC cover | ■ : Height to Z-axis motor

SPECIFICATIONS

Tool Shank

unit : mm(in)

BT40/BBT40, BIG PLUS

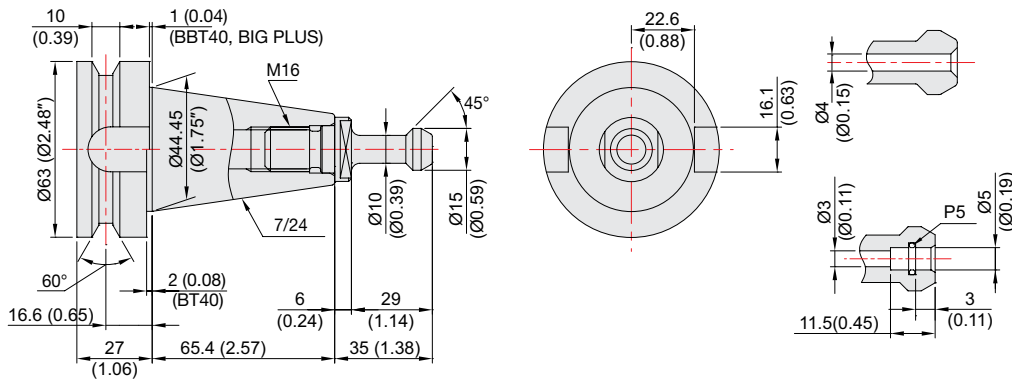

HSK A-63 (Built-in)

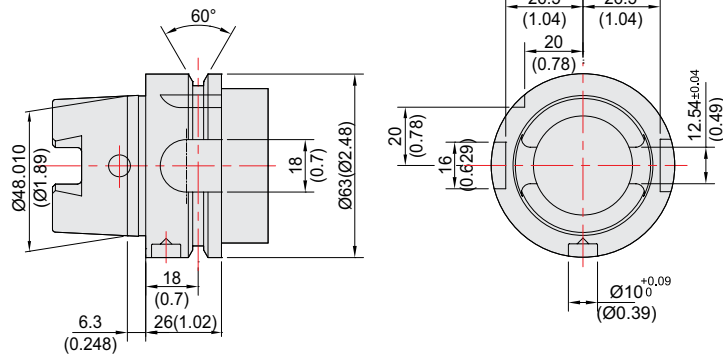

CAT40/BCV40

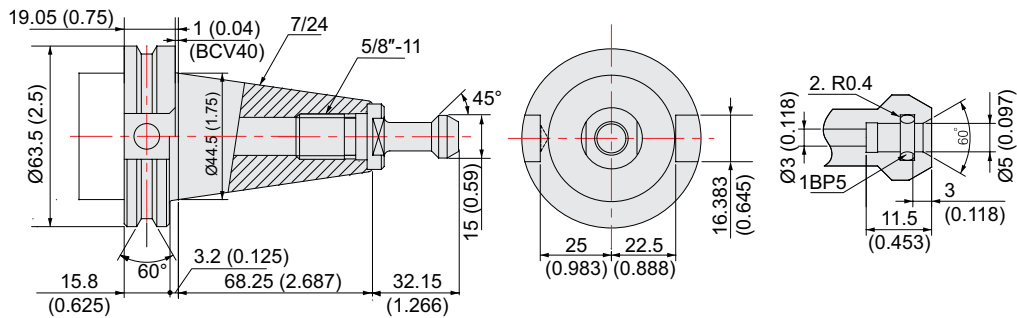

SPECIFICATIONS

Table Dimensions

unit : mm(in)

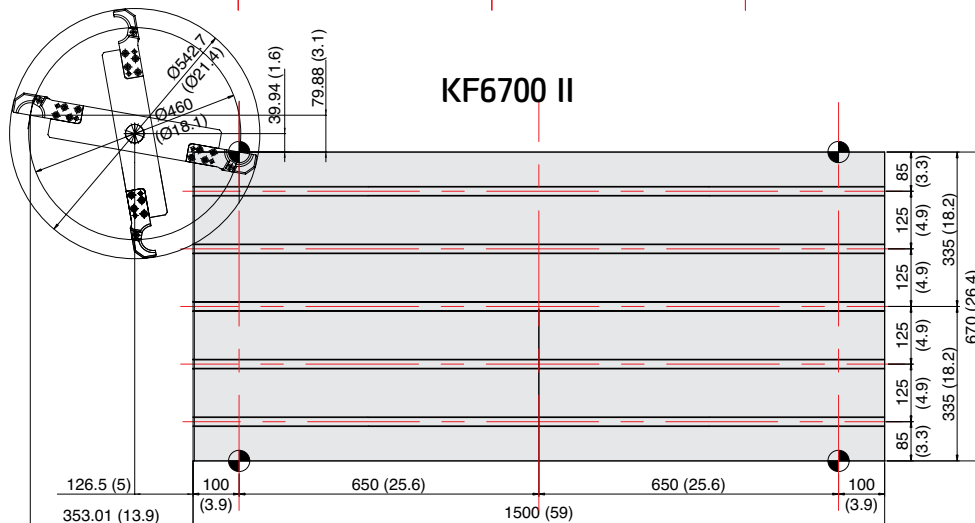
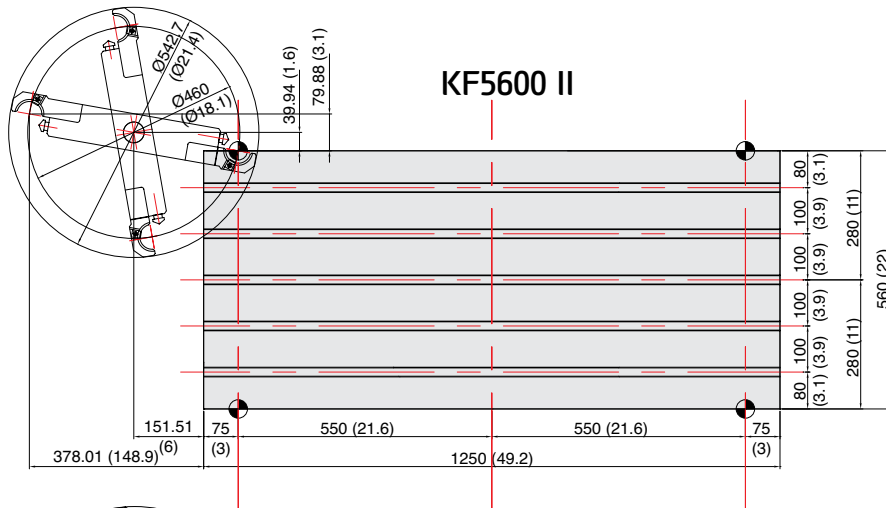
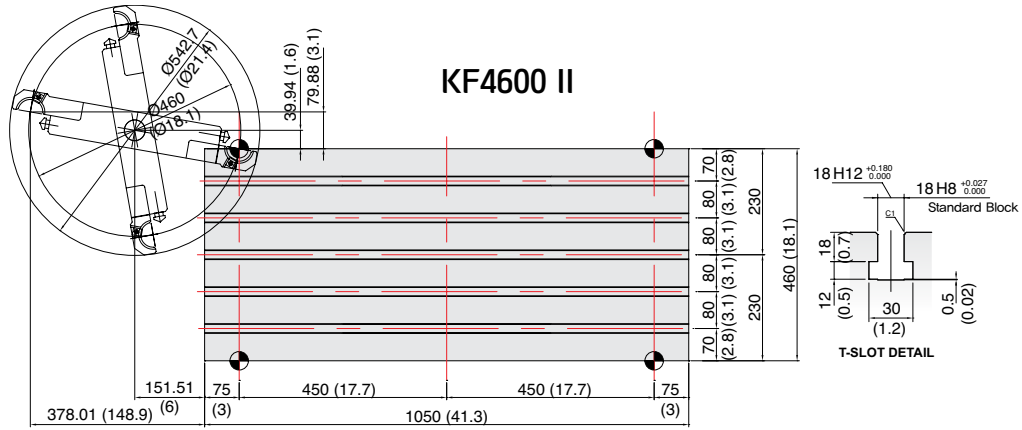

SPECIFICATIONS

Specifications

[] : Option

ITEM		KF4600 II	
TABLE	Table Size (L×W)	mm(in)	1,050×460 (41.3"×18.1")
	Maximum Load Capacity	kg(lb)	600 (1,323)
FEED	Travel (X/Y/Z)	mm(in)	900/460/520 (35.4"/18.1"/20.5")
	Rapid Traverse Rate (X/Y/Z)	m/min	36/36/30 (1,417/1,417/1,181)
	Distance from Table Top to SP. Nose	mm(in)	150 ~ 670 [870] (5.9" ~ 26.4" [34.3"])
	Distance from Column to SP. center	mm(in)	585 (23")
	Slide Type	-	ROLLER TYPE LM GUIDE
ATC	Number of Tools	ea	30 [40]
	Tool Shank	-	BBT40 [12K, 15K : HSK-A63]
	Max. Tool Dia. (W.T / W.O)	mm(in)	30T : Ø80 [40T : Ø76]/Ø125 (30T : Ø3.1" [40T : Ø3"]/Ø4.9")
	Max. Tool Length	mm(in)	300 (11.8")
	Max. Tool Weight	kg(lb)	8
	Tool Selection Method	-	RANDOM [FIXED]
	Tool Change Time	T-T	sec
C-C		sec	3.2
TANK CAPACITY	Coolant Tank	ℓ (gal)	340 (89.8)
	Lubricating Tank	ℓ (gal)	4 (1)
	Hydraulic Tank	ℓ (gal)	- (BOOSTER CYLINDER)
POWER SUPPLY	Air Consumption (0.5MPa)	ℓ /min(gal)	110 (29)
	Electric Power Supply	KVA	26
	Thickness of Power Cable	Sq	Over 25
	Voltage	V/Hz	220/60 (200/50)
MACHINE	Floor Space (L×W)	mm(in)	2,805×2,188 (110.4"×86.1")
	Height	mm(in)	3,319 (130.7")
	Weight	kg(lb)	5,000 (11,023)

Spindle

[] : Option

ITEM	Speed r/min	Power (Max./Cont.) kW (HP)	Torque (Max./Cont.) N·m	Driving Method
HYUNDAI WIA FAPIIC - SMART PLUS	8,000	18.5/11 (25/15)	118/52.5	DIRECT
	[8,000 : High-torque]	15/11 (20/15)	286/143	
	[10,000]	18.5/11 (25/15)	118/52.5	
	[12,000]	18.5/11 (25/15)	118/52.5	
	[15,000]	18.5/11 (25/15)	118/52.5	
HYUNDAI-iTROL	[12,000]	16.2/8.5 (21.7/11.4)	119.7/63	
HEIDENHAIN	[12,000]	17/10 (22.8/13.4)	108.6/63.7	

SPECIFICATIONS

Specifications

[] : Option

ITEM		KF 5600 II	
TABLE	Table Size (L×W)	mm(in)	1,250×560 (49.2"×22")
	Maximum Load Capacity	kg(lb)	1,000 (2,205)
FEED	Travel (X/Y/Z)	mm(in)	1,100/560/520 [635] (43.3"/22"/20.5" [25"])
	Rapid Traverse Rate (X/Y/Z)	m/min	36/36/30 (1,417/1,417/1,181) [42/42/36 (1,654/1,654/1,417)]
	Distance from Table Top to SP. Nose	mm(in)	150 ~ 670 (5.9" ~ 26.4") [150 ~ 785 (5.9" ~ 30.9")] [450 ~ 1,085 (17.7" ~ 42.7")]
	Distance from Column to SP. center	mm(in)	635 (23.4")
	Slide Type	-	ROLLER TYPE LM GUIDE
ATC	Number of Tools	ea	30 [40]
	Tool Shank	-	BBT40 [12K, 15K, 20K : HSK-A63]
	Max. Tool Dia. (W.T / W.O)	mm(in)	30T : Ø80 [40T : Ø76]/Ø125 (30T : Ø3.1" [40T : Ø3"]/Ø4.9")
	Max. Tool Length	mm(in)	300 (11.8")
	Max. Tool Weight	kg(lb)	8
	Tool Selection Method	-	RANDOM [FIXED]
	Tool Change Time	T-T	sec
C-C		sec	3.2 [Z-axis 635 mm (23.4") : 3.5]
TANK CAPACITY	Coolant Tank	ℓ (gal)	365 (96.4)
	Lubricating Tank	ℓ (gal)	4 (1) [BUILT-IN : 4+2 (1+0.5)]
	Hydraulic Tank	ℓ (gal)	- (BOOSTER CYLINDER)
POWER SUPPLY	Air Consumption (0.5MPa)	ℓ /min(gal)	110 (29)
	Electric Power Supply	kVA	26 [BUILT-IN : 32]
	Thickness of Power Cable	Sq	Over 25 [BUILT-IN : Over 35]
	Voltage	V/Hz	220/60 (200/50)
MACHINE	Floor Space (L×W)	mm(in)	2,830×2,178 (111.4"×85.7")
	Height	mm(in)	3,022 (117") [3,437 (135.3")] [BUILT-IN : 2,711 (106.7")]
	Weight	kg(lb)	6,500 (14,330) [7,550 (16,645)]

Spindle

[] : Option

ITEM	Speed r/min	Power (Max./Cont.) kW (HP)	Torque (Max./Cont.) N·m	Driving Method
HYUNDAI WIA FANUC - SMART PLUS	8,000	18.5/11 (25/15)	118/52.5	DIRECT
	[8,000 : High-torque]	15/11 (20/15)	286/143	
	[10,000]	18.5/11 (25/15)	118/52.5	
	[12,000]	18.5/11 (25/15)	118/52.5	
	[15,000]	18.5/11 (25/15)	118/52.5	
FANUC 31i-B	[20,000]	22/18.5	98/80	BUILT-IN
HYUNDAI-ITROL	[12,000]	16.2/8.5 (21.7/11.4)	119.7/63	DIRECT
HEIDENHAIN	[12,000]	17/10 (22.8/13.4)	108.6/63.7	

SPECIFICATIONS

Specifications

[] : Option

ITEM		KF6700 II	
TABLE	Table Size (L×W)	mm(in)	1,500×670 (59"×26.4")
	Maximum Load Capacity	kg(lb)	1,300 (2,866)
FEED	Travel (X/Y/Z)	mm(in)	1,300/670/635 (51.2"/26.4"/25")
	Rapid Traverse Rate (X/Y/Z)	m/min	36/36/30 (1,417/1,417/1,181) [42/42/36 (1,654/1,654/1,417)]
	Distance from Table Top to SP. Nose	mm(in)	150 ~ 785 (5.9" ~ 30.9") [450 ~ 1,085 (17.7" ~ 42.7")]
	Distance from Column to SP. center	mm(in)	690 (27.2")
	Slide Type	-	ROLLER TYPE LM GUIDE
ATC	Number of Tools	ea	30 [40]
	Tool Shank	-	BBT40 [12K, 15K, 20K : HSK-A63]
	Max. Tool Dia. (W.T / W.O)	mm(in)	30T : Ø80 [40T : Ø76]/Ø125 (30T : Ø3.1" [40T : Ø3"]/Ø4.9")
	Max. Tool Length	mm(in)	300 (11.8")
	Max. Tool Weight	kg(lb)	8
	Tool Selection Method	-	RANDOM [FIXED]
	Tool Change Time	T-T	sec
C-C		sec	3.5
TANK CAPACITY	Coolant Tank	ℓ (gal)	365
	Lubricating Tank	ℓ (gal)	4 (1) [BUILT-IN : 4+2 (1+0.5)]
	Hydraulic Tank	ℓ (gal)	- (BOOSTER CYLINDER)
POWER SUPPLY	Air Consumption (0.5MPa)	ℓ/min(gal)	110 (29)
	Electric Power Supply	KVA	26 [BUILT-IN : 32]
	Thickness of Power Cable	Sq	Over 25 [BUILT-IN : Over 35]
	Voltage	V/Hz	220/60 (200/50)
MACHINE	Floor Space (L×W)	mm(in)	3,350×2,529 (131.9"×99.6")
	Height	mm(in)	3,198 (125.9")
	Weight	kg(lb)	8,200 (18,078)

Spindle

[] : Option

ITEM	Speed r/min	Power (Max./Cont.) kW (HP)	Torque (Max./Cont.) N·m	Driving Method
HYUNDAI WIA FAPIIC - SMART PLUS	8,000	18.5/15 (25/20)	118/71.6	DIRECT
	[8,000 : High-torque]	15/11 (20/15)	286/143	
	[10,000]	18.5/11 (25/15)	118/52.5	
	[12,000]	18.5/11 (25/15)	118/52.5	
	[15,000]	18.5/11 (25/15)	118/52.5	
FAPIIC 31i-B	[20,000]	22/18.5 (29.5/25)	98/80	BUILT-IN
HYUNDAI-iTROL	[12,000]	16.2/8.5 (21.7/11.4)	119.7/63	DIRECT
HEIDENHAIN	[12,000]	17/10 (22.8/13.4)	108.6/63.7	

CONTROLLER

HYUNDAI WIA FANUC – SMART PLUS

[] : Option ☆ Needed technical consultation

Controlled axis / Display / Accuracy Compensation	
Control axes	3 axes (X, Y, Z) 4 axes (X, Y, Z, B)
Simultaneously controlled axes	3 axes [Max. 4 axes]
Least setting Unit	X, Y, Z axes : 0.001 mm (0.0001 inch) B axes : 1 deg [0.001] deg
Least input increment	X, Y, Z axes : 0.001 mm (0.0001 inch) B axes : 1 deg [0.001] deg
Inch / Metric conversion	
High response vector control	
Interlock	All axes / Each axis
Machine lock	All axes
Backlash compensation	± 0 ~ 9999 pulses (Rapid traverse / Cutting feed)
Position switch	
LCD / MDI	15 inch LCD unit (with Touch Panel)
Feedback	Absolute motor feedback
Stored stroke check 1	Over travel
Stored stroke check 2, 3	
Stored pitch error compensation	
Operation	
Automatic operation (Memory)	
MDI operation	
DNC operation	Needed DNC software / CF card
Program restart	
Wrong operation prevention	
Program check function	Dry run, Program check, Z axis Machine lock Stored limit check before move
Single block	
Search function	Program Number / Sequence Number
Handle interruption	
Interpolation functions	
Nano interpolation	
Positioning	G00
Linear interpolation	G01
Circular interpolation	G02, G03
Exact stop mode	Single : G09, Continuous : G61
Dwell	G04, 0 ~ 9999.9999 sec
Skip	G31
Reference position return	1st reference, G28 / 2nd reference, G30 Ref. position check, G27
Single direction positioning	G60
Thread synchronous cutting	G33
Helical interpolation	Circular + Linear 2 axes (Max.)
Feed function / Acc. & Dec. control	
Manual feed	Rapid traverse Jog : 0~2,000mm/min (79 ipm) Manual handle : x1, x10, x100 pulses Reference position return
Cutting Feed command	Direct input F code
Feedrate override	0 ~ 200% (10% Unit)
Rapid traverse override	1%, 25%, 50%, 100%
Override cancel	
Feed per minute	G94
Feed per revolution	G95
Cylindrical interpolation	G07.1
Inverse time feed	G93
Look-ahead block	200 blocks (AI APC)
Program input	
Tape Code	EIA / ISO
Optional block skip	1 ea
Absolute / Incremental program	G90 / G91
Program stop / end	M00, M01 / M02, M30
Maximum command unit	± 999,999.999 mm (± 99,999.9999 inch)
Plane selection	X-Y, G17 / Z-X, G18 / Y-Z, G19
Workpiece coordinate system	G52, G53, 48 pairs (G54.1 P1 ~ 48)
Manual absolute	Fixed ON
Programmable data input	G10
Sub program call	10 folds nested
Custom macro	#100 ~ #199, #500 ~ #999
Programmable mirror image	G51.1, G50.1
G code preventing buffering	G4.1
Optional chamfering corner R	

Program input	
Polar coordinate command	G15, G16
Canned cycle	G73, G74, G76, G80 ~ G89
Scaling	G50, G51
Coordinate system rotation	G68, G69
Conversational Program	SmartGuide-i
Auxiliary function / Spindle speed function	
Level-up M Code	Multi / Bypass M code
Spindle speed function	S & S digit, Binary output
Spindle override	0% ~ 150% (10% Unit)
Spindle orientation	M19
Retraction for rigid tapping	
FSSB high speed rigid tapping	
Tool function / Tool compensation	
Tool function	Max. T8 digit
Tool life management	
Tool offset pairs	400 pairs
Tool nose / radius compensation	G40, G41, G42
Tool length offset	G43, G44, G49
Tool offset memory C	Tool geometry and wear (Cutter and tool length)
Tool length measurement	Z axis Input C
Editing function	
Part program storage size	5,120m (2MB)
No. of registerable programs	1,000 ea
Program protect	
Background editing	
Extended part program editing	Copy, move and change of NC program
Memory card program edit	
Data input / output & Interface	
I/O interface	CF card, USB memory Embedded Ethernet interface
Screen hard copy	
External message	
External key input	
External workpiece number search	
Automatic data backup	
Setting, display and diagnosis	
Self-diagnosis function	
History display & Operation	Alarm & Operator message & Operation
Run hour / Parts count display	
Maintenance information	
Actual cutting feedrate display	
Display of spindle speed / T code	
Graphic display	
Operating monitor screen	Spindle / Servo load etc.
Power consumption monitoring	Spindle & Servo
Spindle / Servo setting screen	
Multi language display	Support 24 languages
Display language switching	Selection of 5 optional Languages
LCD Screen Saver	Screen saver

Option	
Additional optional block skip	9 ea ☆
Fast ethernet	Needed option board
Data server	Needed option board
Protection of data at 8 levels	
Additional Axis	
Manual handle feed	2/3 units
Addition of custom macro	#100 ~ #199, #500 ~ #999, #98000 ~ #98499
Add. Workpiece	Max. 300 pairs (G54.1 P1 ~ P300)
AICC II	400 blocks ☆

Figures in inch are converted from metric values.

The FANUC controller specifications are subject to change based on the policy of company CNC supplying.

CONTROLLER

FANUC 31i-B

[] : Option ☆ Needed technical consultation

Controlled axis / Display / Accuracy Compensation	
Control axes	3 axes (X, Y, Z) 4 axes (X, Y, Z, B)
Simultaneously controlled axes	3 axes [Max. 4 axes]
Least setting Unit	X, Y, Z axes : 0.001 mm (0.0001 inch) B axes : 1 deg [0.001] deg
Least input increment	X, Y, Z axes : 0.001 mm (0.0001 inch) B axes : 1 deg [0.001] deg
Inch / Metric conversion	G20 / G21
High response vector control	
Interlock	All axes / Each axis
Machine lock	All axes
Backlash compensation	± 0 ~ 9999 pulses (Rapid traverse / Cutting feed)
Position switch	
LCD / MDI	10.4 inch color LCD
Feedback	Absolute motor feedback
Stored stroke check 1	Over travel
Stored pitch error compensation	
Operation	
Automatic operation (Memory)	
MDI operation	
DNC operation	Needed DNC software / CF card
Program restart	
Wrong operation prevention	
Program check function	Dry run, Program check Z axes Machine lock, Stroke check before move
Single block	
Search function	Program Number / Sequence Number
Interpolation functions	
Nano interpolation	
Positioning	G00
Linear interpolation	G01
Cylindrical interpolation	G02, G03
Exact stop mode	Single : G09, Continuous : G61
Dwell	G04, 0 ~ 9999.9999 sec
Skip	G31
Reference position return	1st reference : G28 2nd reference : G27 Ref. position check : G30
Thread synchronous cutting	G33
Helical interpolation	Circular + Linear interpolation 2 axes(max.)
Feed function / Acc. & Dec. control	
Manual feed	Rapid traverse Jog : 0~5,000mm/min (197 ipm) Manual handle : x1, x10, x100 pulses Reference position return
Cutting Feed command	Direct input F code
Feedrate override	0 ~ 200% (10% Unit)
Rapid traverse override	F0% (F1%), F25%, F50%, F100%
Override cancel	
Feed per minute	G94
Feed per revolution	G95
Look-ahead block	40 Block 200 Block (Mold)
Program input	
Tape Code	EIA / ISO
Optional block skip	1 ea
Absolute / Incremental program	G90 / G91
Program stop / end	M00, M01 / M02, M30
Maximum command unit	± 999,999.999 mm (± 99,999.9999 inch)
Plane selection	X-Y : G17 / Z-X : G18 / Y-Z : G19
Workpiece coordinate system	G52, G53, 6 pairs (G54 ~ G59)
Manual absolute	Fixed ON
Programmable data input	G10
Sub program call	10 folds nested
Custom macro	#100 ~ #149, #500 ~ #549
G code system	A
Programmable mirror image	G51.1, G50.1
G code preventing buffering	G4.1
Including Chamfering / Corner R	
Canned cycle	G73, G74, G76, G80 ~ G89
Coordinate rotation	G68, G69

Auxiliary function / Spindle speed function	
Auxiliary function	M 4 digit
Level-up M Code	Multi / Bypass M code
Spindle speed command	S 5 digit, Binary output
Spindle override	0% ~ 150% (10% Unit)
Spindle orientation	M19
FSSB high speed rigid tapping	
Tool function / Tool compensation	
Tool function	Max. T 8 digit
Tool life management	256 pairs ☆
Tool offset pairs	64 pairs
Tool nose radius compensation	G40, G41, G42
Tool nose length compensation	G43, G44, G49
Tool offset memory C	Tool length, diameter, abrasion(length, diameter)
Tool length measurement	Z axes Input C
Editing function	
Part program storage size	640m (256KB)
No. of registerable programs	500 ea
Program protect	
Background editing	
Extended part program editing	Copy, move and change of NC program
Memory card program edit	
Data input / output & Interface	
I/O interface	RS 232C serial port, CF card, USB memory Embedded Ethernet interface
Screen hard copy	
External message	
External key input	
External workpiece number search	
Automatic data backup	
Setting, display and diagnosis	
Self-diagnosis function	
History display	Alarm & Operator message & Operation
Run hour / Parts count display	
Maintenance information	
Actual cutting feedrate display	
Display of spindle speed / T code	
Graphic display	
Operating monitor screen	Spindle / Servo load etc.
Power consumption monitoring	Spindle & Servo
Spindle / Servo setting screen	
Multi language display	Support 20 languages
Display language switching	Selection of 5 optional Languages
LCD Screen Save	Screen saver
Processing select	Speed/rigidity setting
Option	
Additional optional block skip	9 ea ☆
Fast ethernet	Needed option board
Data server	Needed option board
Protection of data at 8 levels	
Sub Spindle control	
Polar coordinate command	G15, G16
Polar coordinate interpolation	G12.1, G13.1
Cylindrical interpolation	G07.1
One-way positioning	G60
Stored stroke check 2, 3	
Inverse-time feed	G93
Scaling	G50, G51
Manual guide i	Conversational auto program
Handle interrupt	
Manual handle feed	2/3 units
Additional custom macro variables	#100~#199, #500~#999
Retraction for rigid tapping	#100~#199, #500~#999, #98000~#98499
Tool management function	
Tool offset number	Max. 2000 pair ☆
Program storage capacity	512KB ~ 8MB ☆
Program registration number	Max. 4000 ea ☆
Additional work coordinate	Max. 48 pair (G54.1 P1 ~ P48)
AICC II	200 block 400 / 600 / 1000 block ☆

Figures in inch are converted from metric values.

The FANUC controller specifications are subject to change based on the policy of company CNC supplying.

GLOBAL NETWORK



HEADQUARTER

Changwon Technical Center/R&D Center/Factory

153, Jeongdong-ro, Seongsan-gu, Changwon-si, Gyeongsangnam-do, Korea
(Zip Code : 51533) TEL : +82 55 280 9114 FAX : +82 55 282 9680

Uiwang Technical Center/R&D Center

37, Cheoldobangmulgwan-ro, Uiwang-si, Gyeonggi-do, Korea
(Zip Code : 16082) TEL : +82 31 596 8209 Fax : +82 55 210 9804

OVERSEAS OFFICES

EUROPE

HYUNDAI WIA Machine Tools Europe / Europe R&D Center

Alexander-Fleming-Ring 57, 65428 Rüsselsheim Germany
TEL : +49-0-6142-9256-0

HYUNDAI WIA Russia

Russia, 197374, St. Petersburg, Torfyanaya doroga 7,
Business center <Gulliver-2>, Office No. 825

ASIA

Beijing HYUNDAI WIA

No.9, West of Shunxi South Road, Renhe Town, Shunyi District, Beijing, China
TEL : +86-10-6049-6373

Beijing Branch Office

1401, Zhonghangji Plaza B, No. 15 Ronghua South Road, BDA Dist, Daxing Dist,
Beijing, China, 100176
TEL : +86-10-8453-9850

Shandong HYUNDAI WIA

Company No.188 Shanghai Road, Rizhao City, Shandong Province, China
TEL : +86-633-229-9021

Chengdu Branch Office

No.508 Room, B Block, AFC Plaza, No.88 Jiaozhi Road, High-tech Zone, Chengdu,
China
TEL : +86-28-8666-4470

Jiangsu HYUNDAI WIA

Company No.6 Fenghuang Road, Fenghuang Town, Zhangjiagang City, Jiangsu
Province, China
TEL : +86-512-5842-2500

Qingdao Branch Office

Room 1207, Caifu Building, 182-6 Haier Middle Road, Qingdao, China
TEL : +86-532-8667-9334

HYUNDAI WIA Machine Tools China

1-3F, Bldg6, No.1535 Hongmei Road, Xuhui District, Shanghai, China
TEL : +86-21-6427-9885

India Branch Office

#4/169, 1st Floor, LOTTE BLDG, Rajiv Gandhi Salai, (OMR), Kandanchavadi, Chennai
- 600096, Tamilnadu, India
TEL : +91-76-0490-1618

HYUNDAI WIA India

48, Sur.No78-80, Kandamangalam Village, Sengadu Post, Sriperumbudur Taluk,
Kancheepuram, Tamil Nadu-602 105, India
TEL : +91-44-2715-9302

Vietnam Branch Office

Flat number 05, Service and Trade Center of Viet Huong Industrial Zone, Highway
13, Thuan Giao, Thuan An, Binh Duong, Vietnam
TEL : +84-3-5399-5099

AMERICA

HYUNDAI WIA Machine America corp.

450 Commerce Blvd, Carlstadt, NJ 07072, USA
TEL : +1-201-987-7298

HYUNDAI WIA America R&D Center

39205 Country Club Drive Suite C-9, Farmington Hills, MI 48331, USA
TEL : +1-248-324-1057

HYUNDAI WIA Mexico

Carretera a Pesquería-Los Ramones KMS 13 al 15 Interior 18 Localidad "La Arena"
Pesquería C.P.66679, Nuevo León México
TEL : +52-1-81-1646-5208

HYUNDAI
WIA

EXPERIENCE THE NEW TECHNOLOGY

With its top-quality HYUNDAI WIA machine tool creates a new and better world.



<http://machine.hyundai-wia.com>

HYUNDAI WIA Machine Tools
Global Links

2020-05 001.001 ENG