

KH50G/63G

HYUNDAI WIA Horizontal Machining Center



Technical Leader

Horizontal Machining Center KH50G/63G designed by Hyundai WIA with years of expertise and the latest technology, features 2 Step geared spindle for highly rigid and accurate machining to maximize productivity.



KH50G

[] : Option ● : HYUNDAI-ITROL

Pallet Size	mm(in)	2-500×500 (2-19.7"×19.7")
Max. Load Capacity	kg(lb)	2-800 (2-1,764)
Spindle Taper	-	NT #50
Spindle Speed	rpm	4,500 [4,500] [8,000] [8,000] [4,500] [8,000]
Spindle Output	kW(HP)	18.5 (24.8)[22 (29.5)][18.5 (24.8)][22 (29.5)] [18 (24.1)] [18 (24.1)]
No. of Tools	EA	40 [60, 90, 120]
Travel(X/Y/Z)	mm(in)	760/705/650 (29.9"/27.8"/25.6")

KH63G

[] : Option ● : HYUNDAI-ITROL

Pallet Size	mm(in)	2-630×630 (2-24.8"×24.8")
Max. Load Capacity	kg(lb)	2-1,000 (2-2,205)
Spindle Taper	-	NT #50
Spindle Speed	rpm	4,500 [4,500] [8,000] [8,000] [4,500] [8,000]
Spindle Output	kW(HP)	22 (29.5)[26 (34.9)][22 (29.5)][26 (34.9)] [22.2 (29.8)] [22.2 (29.8)]
No. of Tools	EA	40 [60, 90, 120]
Travel(X/Y/Z)	mm(in)	950/825/760 (37.4"/32.5"/29.9")

Robust Machining Center with
Revolutionary Productivity

KH50G/63G

- 2 Step Gear on Main Spindle for Heavy Duty Cutting
- Standard Oil Cooling System for High Precision
- Shuttle Type APC
- Box Guides on All Axis for Ultra Rigidity
- Air Semi-Rising Slideway on Z-axis
- 8-Face Contact Y-axis Guideway
- Specially Designed Columns that Minimizes Thermal Displacement
- Tool Magazine Capacity of up to 120 Tools (OPTION)



01

KH50G/63G

Basic Features

Heavy Duty Cutting Horizontal Machining Center



01

X/Z Axis All-in-One Structure

All-in-one bed structure leads to enhanced structural rigidity.

Box Guideway for All Axes

KH50G/63G is designed with box guideways which show great performance in offsetting vibration. Therefore, it is possible to efficiently machine difficult to cut materials into high precision products.

Air Semi-Rising Slide Way

By applying the air semi-rising slideways, the load on the Z-axis slideway is decreased. Therefore, positioning and repeatability accuracy can be maintained for a long time.



Spindle

KH50G/63G is designed with a 2-step gear drive, which provides high torque at low rpm and stability at high rpm and this enables a wide range of machining.

02

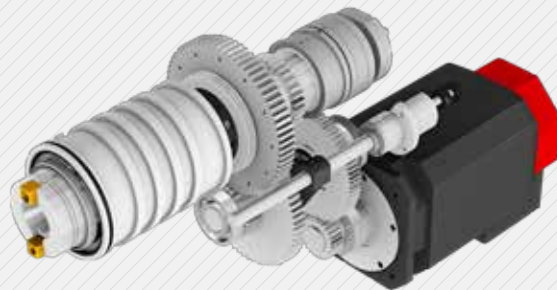

Shuttle Type APC

Productivity is improved through Shuttle Type APC that makes large sized work piece machining easier.

03

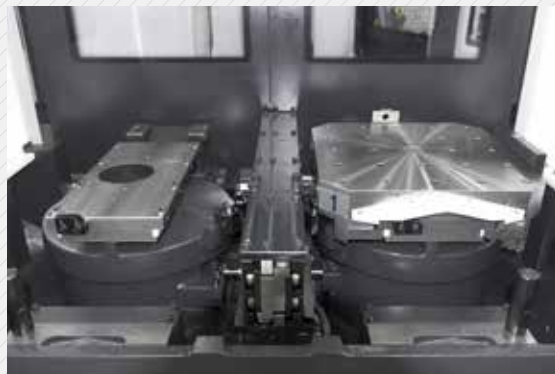

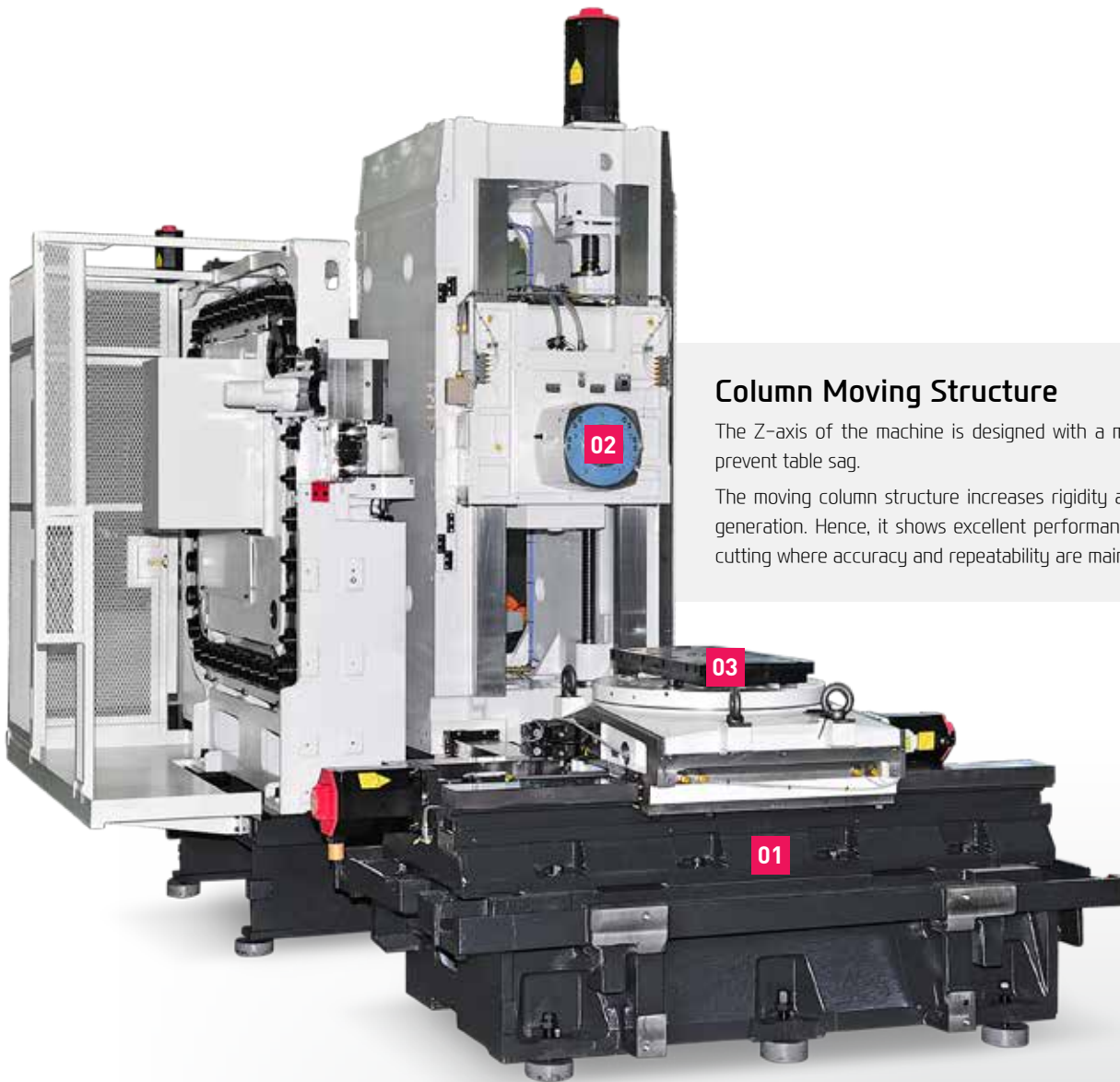

Column Moving Structure

The Z-axis of the machine is designed with a moving column to prevent table sag.

The moving column structure increases rigidity and reduces heat generation. Hence, it shows excellent performance in heavy duty cutting where accuracy and repeatability are maintained.

Powerful Cutting Capability & Large Working Area

- ◎ **Travel** (X/Y/Z axis) KH50G : 760/705/650 mm (29.9"/27.8"/25.6")
KH63G : 950/825/760 mm (37.4"/32.5"/29.9")
- ◎ **Rapid Traverse Rate** (X/Y/Z axis) : 20/20/20 m/min (787/787/787 ipm)

02

KH50G/63G

Powerful Cutting Spindle

High Productivity Achieved
with High Rigidity and High Precision

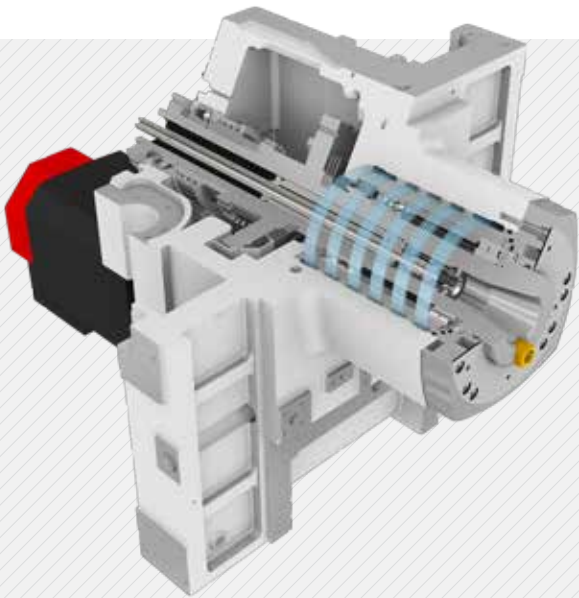

High Rigidity, High Precision Spindle

By using ultra precision class cylindrical roller-bearings, fast acceleration and deceleration of the main spindle is achieved.

The spindle head is designed to minimize thermal displacement of the main spindle, and with the use of a hydraulic tool lock system the machining stability has been increased.

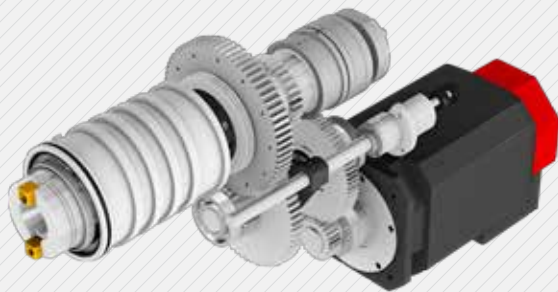

2-Step Geared Spindle

KH50G/63G is designed with a 2-step gear drive, which provides high torque at low rpm and stability at high rpm.

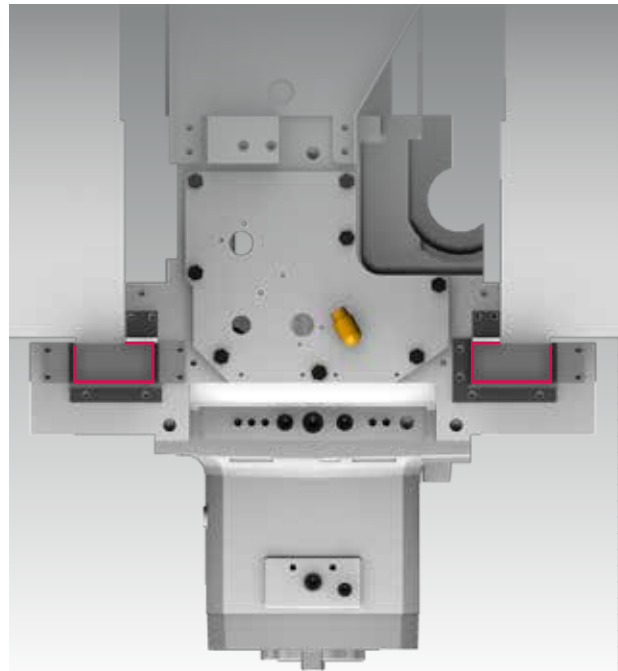

8-face Contact Y-axis Guideway

Spindle head contacts 8 faces of Y-axis guideway. This new method allows cutting forces generated by the spindle head to be absorbed by the Y-axis box guideways which improves heavy duty cutting ability, accuracy, and surface finish.

Tool Holders

BT and CAT(Opt) tool holders are applicable.

CAT 50
OPTION



BT50

Dual Contact Spindle **OPTION**

The Big Plus spindle system (BBT) provides dual contact between the spindle face and the flange face of the tool holder.

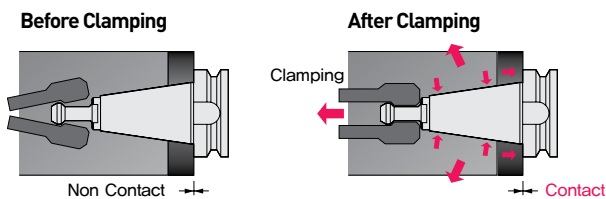

The increase in standard diameter improves rigidity and ATC repeatability, and Z-axis displacement is prevented which further extends tool life.

Through Spindle Coolant **OPTION**

Through Spindle Coolant is exceedingly useful when drilling deep holes. It helps increase the lifetime of the tool, while decreasing cycle time



20 bar / 30 bar / 70 bar
(290 psi / 435 psi / 1,015 psi)

Spindle Cooling

The spindle cooling system minimizes thermal displacement which can happen during lengthy machining operations, and offers continued accuracy based on the thermal stability.

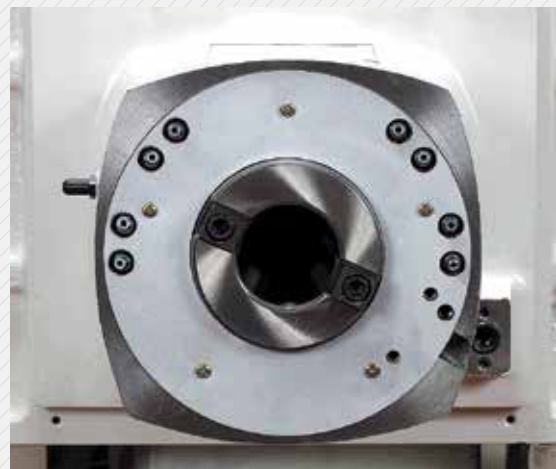
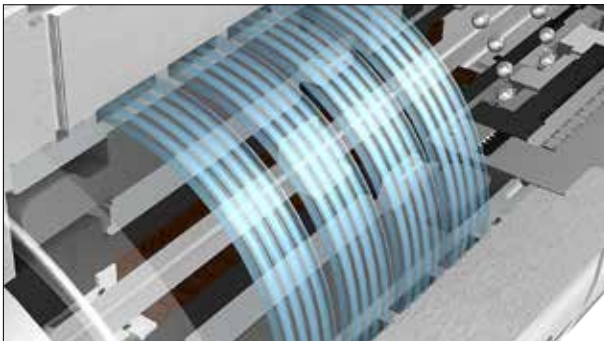

8 Nozzles Directing Coolant

8 nozzles on the spindle improve precision by providing coolant on the machining area where direction of injection can be adjusted.

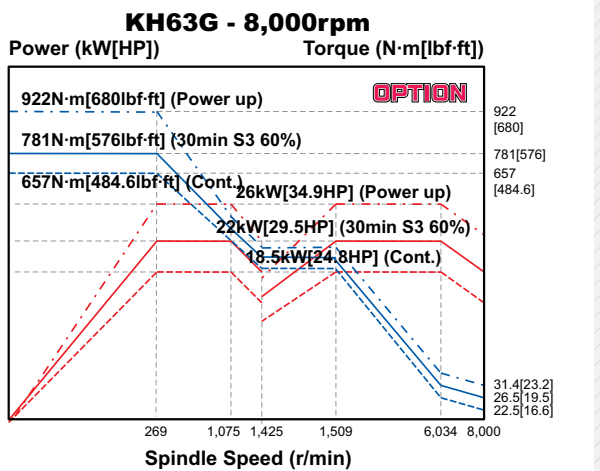
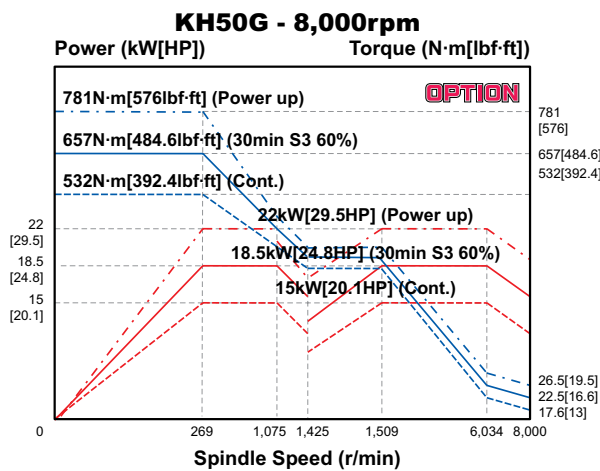
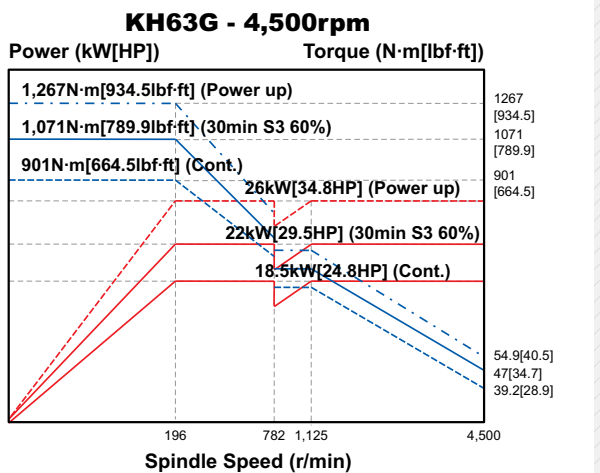
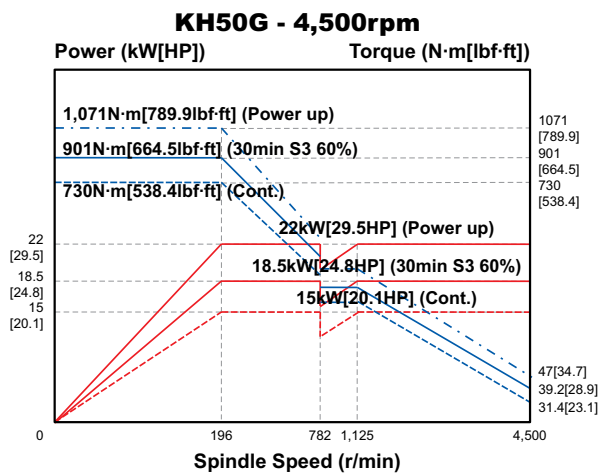

KH50G 4,500 rpm

18.5 kW (24.8HP)
Max. Output

901 N·m (664.5lbf-ft)
Max. Torque

KH50G 4,500 rpm (Opt.)

22 kW (29.5HP)
Max. Output

1,071 N·m (789.9lbf-ft)
Max. Torque

KH50G 8,000 rpm (Opt.)

18.5 kW (24.8HP)
Max. Output

657 N·m (484.6lbf-ft)
Max. Torque

KH50G 8,000 rpm (Opt.)

22 kW (29.5HP)
Max. Output

781 N·m (576lbf-ft)
Max. Torque

KH63G 4,500 rpm

22 kW (29.5HP)
Max. Output

1,071 N·m (789.9lbf-ft)
Max. Torque

KH63G 4,500 rpm (Opt.)

26 kW (34.9HP)
Max. Output

1,267 N·m (934.5lbf-ft)
Max. Torque

KH63G 8,000 rpm (Opt.)

22 kW (29.5HP)
Max. Output

781 N·m (576lbf-ft)
Max. Torque

KH63G 8,000 rpm (Opt.)

26 kW (34.9HP)
Max. Output

922 N·m (680lbf-ft)
Max. Torque

HYUNDAI-iTROL

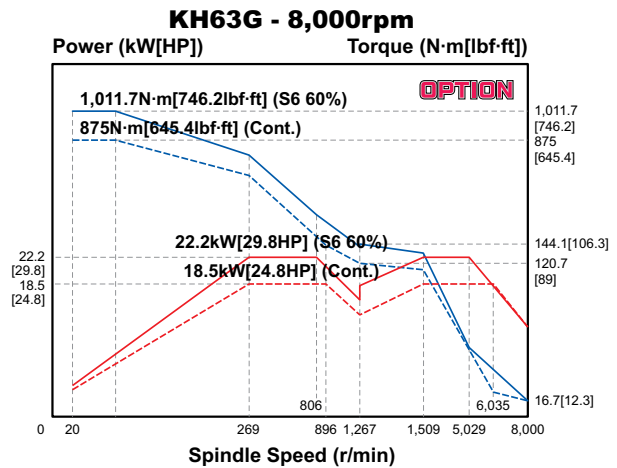
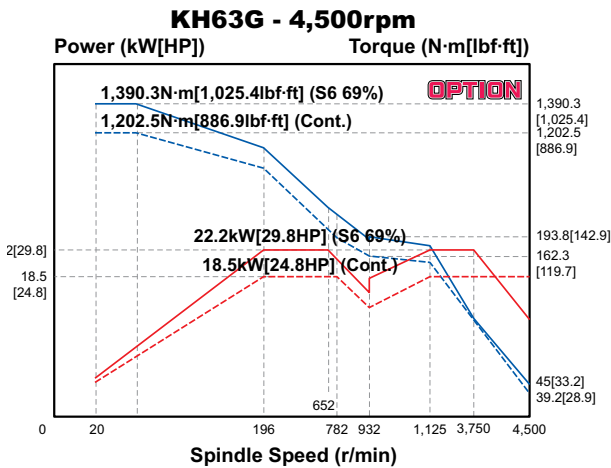
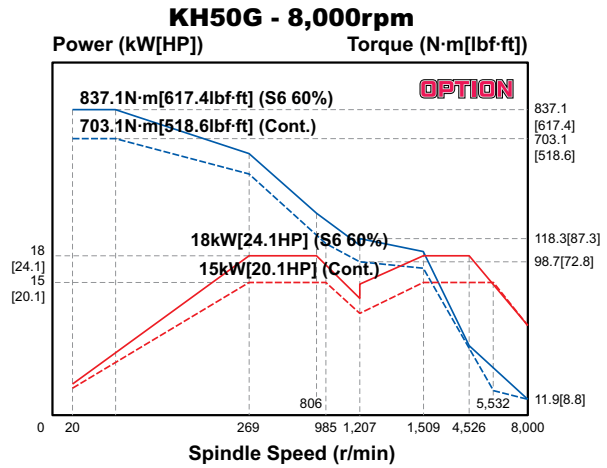
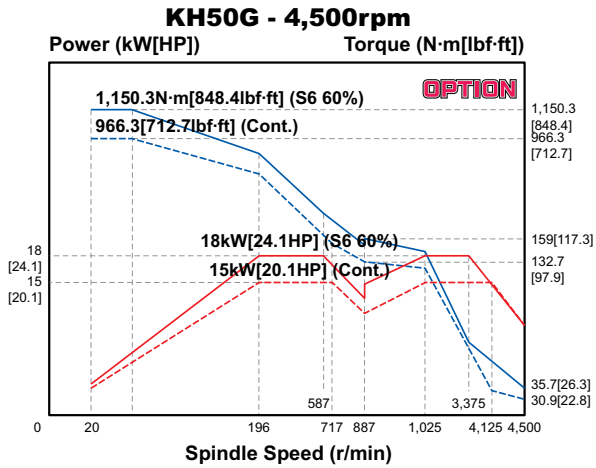

KH50G 4,500 rpm (Opt.)

18 kW (24.1HP) Max. Output **1,150.3** N·m (848.4lbf·ft) Max. Torque

KH50G 8,000 rpm (Opt.)

18 kW (24.1HP) Max. Output **837.1** N·m (617.4lbf·ft) Max. Torque

KH63G 4,500 rpm (Opt.)

22.2 kW (29.8HP) Max. Output **1,390.3** N·m (1,025.4lbf·ft) Max. Torque

KH63G 8,000 rpm (Opt.)

22.2 kW (29.8HP) Max. Output **1,011.7** N·m (746.2lbf·ft) Max. Torque

03

KH50G/63G

APC & Pallet

Long Lasting High Accuracy & Excellent Performance
Horizontal Machining Center

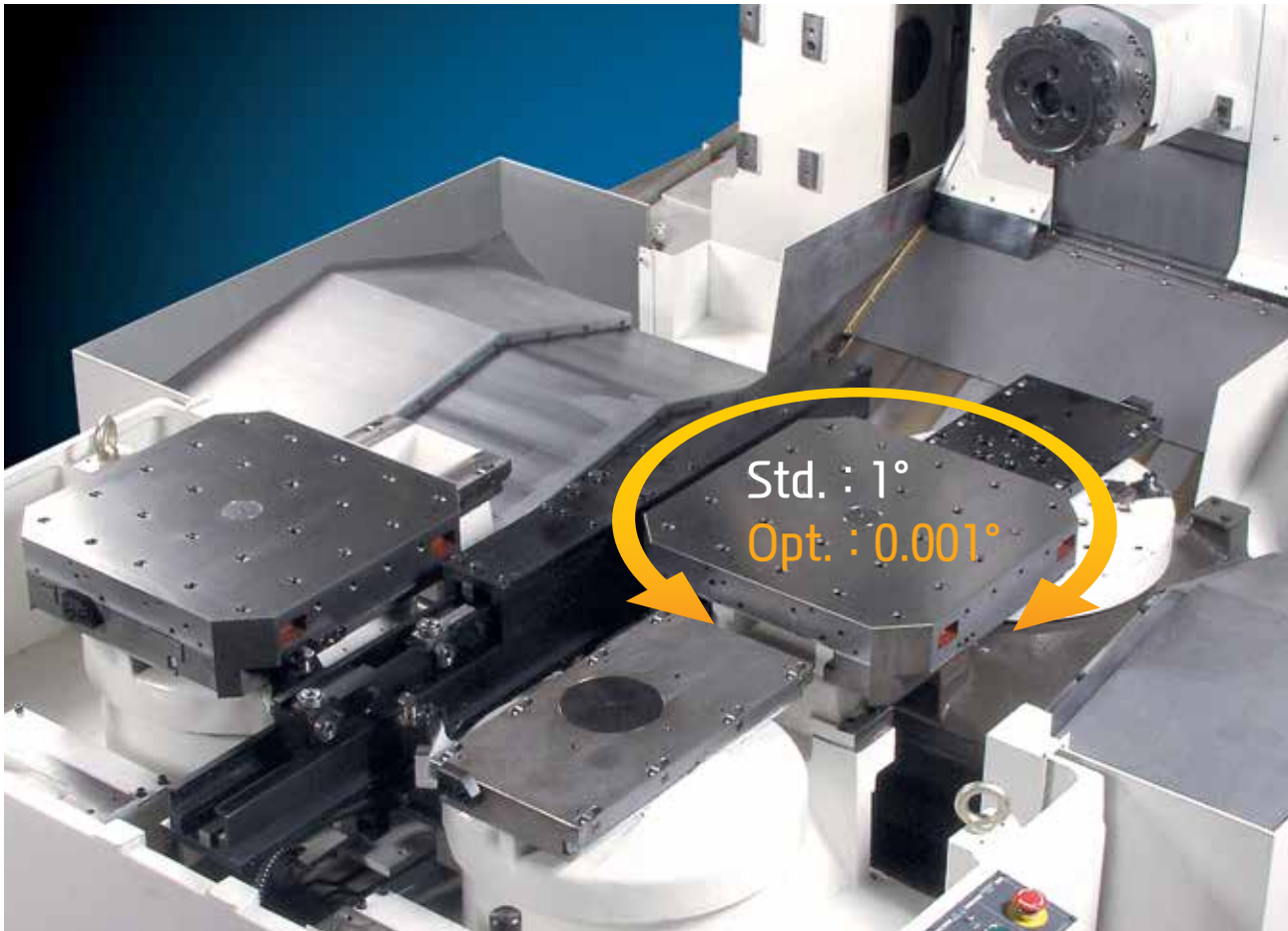

Shuttle Type APC

KH50G/63G is equipped with a shuttle type APC (Automatic Pallet Changer) as standard.
The pallet can be rotated in the loading station for quick and easy load/unload of machined parts.

● Tap Pallet

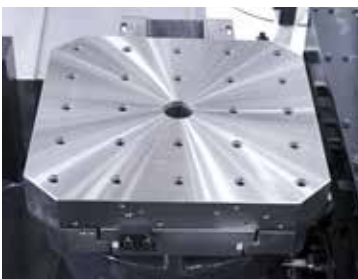

● T-Slot Pallet **OPTION**



● Pallet Size

KH50G : **2-500×500** mm
(**2-19.7"×19.7"**)

KH63G : **2-630×630** mm
(**2-24.8"×24.8"**)

APC Safety Sensor

Safety Sensors on APC covers detect the presence of operators near APC. When a contact is detected on the beam, APC Automatically stops. This helps establish a safe work environment.

Enhanced Convenience of APC

An additional control panel is provided for APC operating.

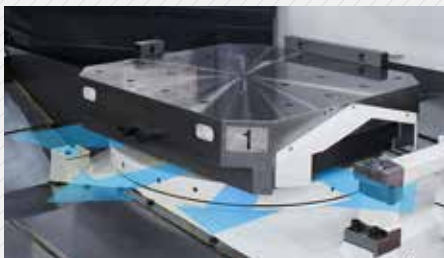

Air Clearing System

During the pallet change cycle, strong air blasts from the taper cones on the machine table helps remove chips to provide clean surface for locating the pallet.

This ensures high accuracy of pallet positioning and guarantees optimum rigidity.

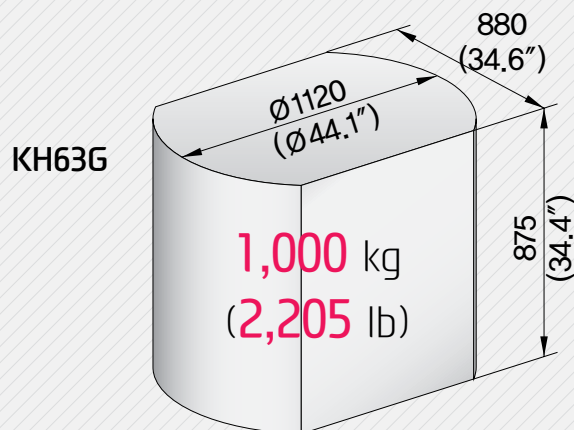
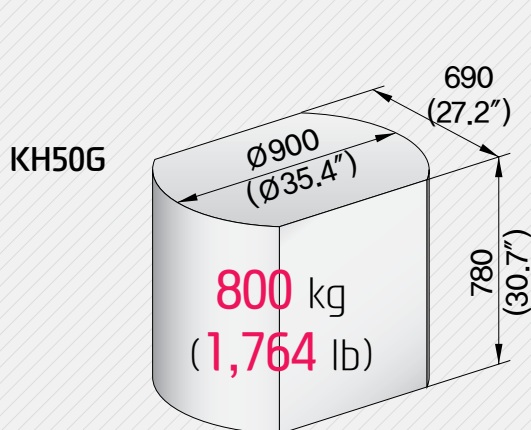

n4
KH50G/63G

Magazine & ATC

High Productivity Achieved
with High Rigidity and High Precision



Magazine

KH50G/63G offers various tool magazines which expand the range of machining. Also, fixed address tool selection method and 2 types of ATC cycles for heavy tools and standard tools increase convenience.



- Std. Tool Weight :
20 kg (44 lb)
- Max. Tool Weight :
35 kg (77 lb)

40 Tool

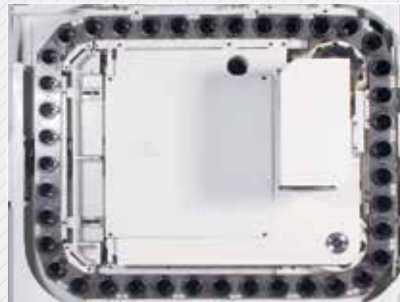

60 Tool **OPTION**

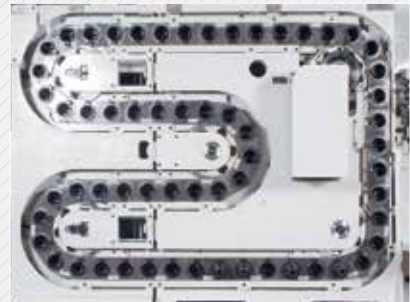

90 Tool **OPTION**



120 Tool **OPTION**



ATC Air Blow & Brush

Tool holders are automatically cleaned by an air blow and brush when they are placed in the standby position.

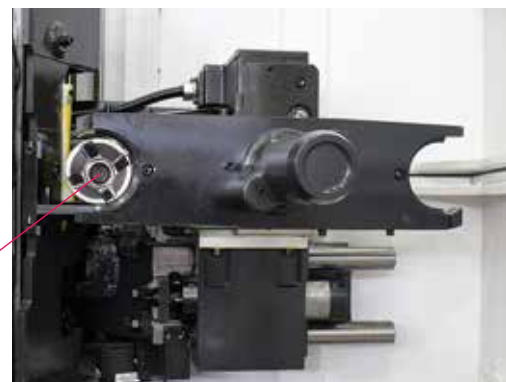
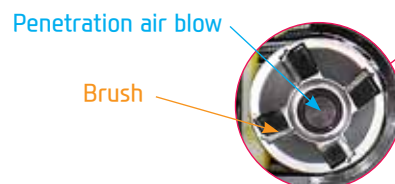

05

KH50G/63G

iRiS HYUNDAI WIA Smart Factory Solution

integrated Revolution of industrial Solution

iRiS is HYUNDAI WIA's Smart Factory Solution.

iRiS, HYUNDAI WIA's revolutionary smart factory solution, consists of **Smart Monitoring System** for integrated management of HYUNDAI WIA machines around the world, and the **Smart Machining System** with ease, quality control, productivity and safety of the operator in mind.

SMART MONITORING

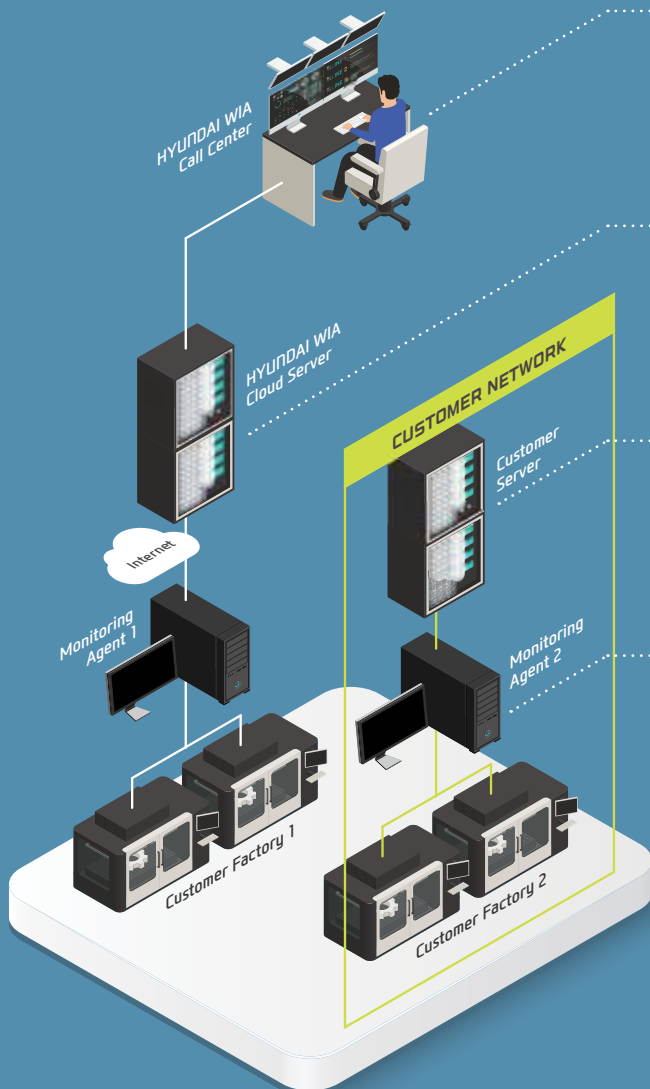

HW-MMS Remote (Remote service based)

Hyundai Wia Call Center's remote diagnosis service provides a HMI/video diagnostic function.



HW-MMS Cloud (Cloud server based)

A cloud server-based equipment monitoring system for collecting and analyzing facility operation data.



HW-MMS Edge (Customer Server Based)

A customer server-based equipment monitoring system for collecting and analyzing facility operation data.



HW-MMS Collector (Machine data collector)

A dedicated program for collecting CNC data for MES/ERP.

A brand new manufacturing machine by Hyundai Wia, HW-MMS is a unique software capable of monitoring the operation status of manufacturing machines in factories, a **smart solution** to improve manufacturing conditions of customers.

SMART MACHINING



HW-MCG
HYUNDAI WIA
Machine Guidance

Software that offers operation, maintenance, management monitoring and various user friendly features.



HW-TM
HYUNDAI WIA
Tool Monitoring

A tool monitoring software which analyzes the load of the spindle motor to determine and monitor possible damage of tools.



HW-MCS
HYUNDAI WIA Machining
Condition Selection

Software that automatically sets cutting and feeding parameters according to the machining types (speed, degree, quality)



HW-WARMUP
HYUNDAI WIA
WARMing Up

Warm-up software that measures main spindle halt and offers system warm-up time automatically.



HW-DPRO
HYUNDAI WIA
Dialogue PROGRAM

Software to create machining program easily and quickly through interactive operation



HW-TDC
HYUNDAI WIA Thermal
Displacement Compensation

Software that measures the changes in the external environment as well as heat emission during processing to help reduce thermal displacement.



HW-AFC
HYUNDAI WIA
Adaptive Feed Control

Software that controls the feed automatically to maintain a certain working load to extend tool life as well as productivity.



HW-ESS
HYUNDAI WIA
Energy Saving System

An environmental friendly software that reduces the unnecessarily wasted standby power waiting for an operation.



RENISHAW GUI
Work / Tool Offset
Measurement

User-friendly GUI software for material coordinate system, tool length / diameter/breakage measurement (included in RENISHAW H/W set)



HW-eDNC
HYUNDAI WIA ethernet
Direct Numerical Control

This software allows transmission of NC data between PC and a machine's CNC. The processing programs can be managed on the PC through the ethernet or serial communication.

n6

KH50G/63G

HYUNDAI-iTROL

The Powerful CNC Platform for Machine Tools



COMMUNICATION FUNCTION

RJ 45 Ethernet

USB 2.0

Compact Flash Card



Easy input/output of programs is possible with the use of USB memory card, CF memory card and LAN.



Energy Saving & ECO System



Energy Saving System

You can use energy saving function (ECO) and machining optimization function (SMART) with the MCP button.

HYUNDAI Intelligent Control

Convenient and Easy-to-Use Machine Tool...

Hyundai WIA take operator convenience to a higher level with the new controller, HYUNDAI-iTROL. Experience the new operating environment with HYUNDAI-iTROL.

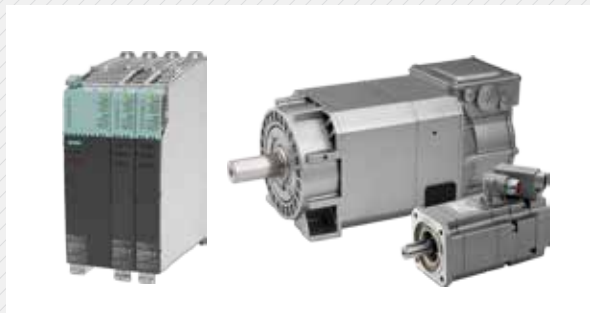

Combination of HYUNDAI-iTROL with Siemens servo drive and motor offers the optimum machine tool solution!

Dynamic servo control, highly efficient Siemens servo drive and Siemens servo motor with durability and quick response have been applied.

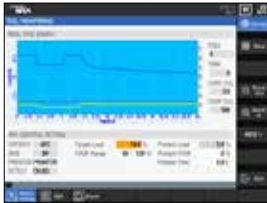

Tool Monitoring, AFC

- The same tool monitoring function as the Fanuc HW-TM + new AFC
- Automatic transfer speed control
 - Expected benefits : Tool monitoring possible even when machining molds and prototype products, etc. Shortens the cycle time and protects the machine through an active control function



Measuring System

- Simplified UI by removing unnecessary screens
- Compatible with the standard Renishaw/Marposh as well as third-party TLM (the measuring program needs to be converted into TLM.SPF)
- Continuous measuring function to measure 10 tools at a time
- Tool data comparison (before and after measuring) and enhanced animation function



Coordinate System Setting

- Quicker setting of coordinate system enabled by an improved UI (using the top-left coordinate system value)
- Parameter change process has been changed to "enter all and apply later" type to prevent the worker's erroneous entry
- Pre-defined coordinate value displayed in the bottom bed image for easier identification
- A 'Spindle rotation' button added for easier spindle rotation



Engraving Setting

- Ability to engrave model name/serial number in mass production
- Available in the program edit window
- Text, quantity of work, working date, working time can be engraved and ordered
- Easily and quickly apply the engraved functions of Siemens CYCLE



Monitoring of Operating Ratio

- Intuitive display uses distinctive colors to indicate the 4 stages of alarm, cycle, setup, and inactivity.
- Displays current activated status as "Activated".
- Options to export 10-day operation history as an PC file or to CF card (MS Excel compatible format)



Warming-up

- The mode selection path simplified with an improved UI
- Except Tool, Spindle RPM, Time, Program, the parameters not used frequently have been moved to 'Settings' screen.
- Messages for the current progress (%) and remaining time displayed at the top of the screen

Shop Turn

OPTION



- Dialogue-type programming, simple and convenient
- Effective specifications for small quantity batch production
- Step-by-step operation possible without knowledge of the DIN/ISO code

3D Simulation

OPTION

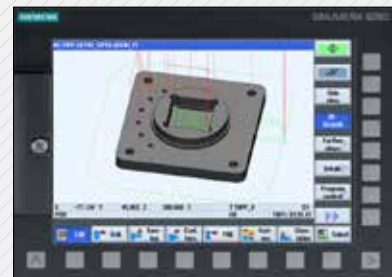

- 3D confirmation of the completed processing configuration of the NC program is possible.
- Offers standards for 2D simulation.
- Possible to confirm the simulation of the NC program during processing.

ISO Code Programming

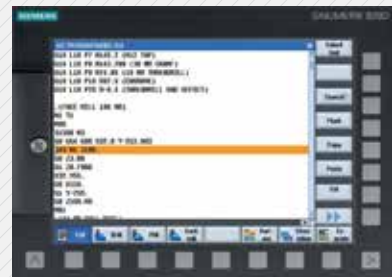

If the ISO Dialect (G291) is ordered, JIS-based G-code programs can be used. (Standard)

07

KH50G/63G

User Convenience



Various Devices for User Convenience

Measuring Device

Work Measuring

Workpiece coordinate values can be set automatically using the optional spindle probe.



Tool Measuring

Tool lengths and diameters can be set automatically using the optional tool setter. This can also be used to monitor tool attrition and detect broken tools.



Laser Type



Touch Type

Precision Device

Linear Scale & Rotary Scale

Linear scale and rotary scale help process highly accurate products through precise positioning.



Linear Scale



Rotary Scale

NC Rotary Table

The NCRT makes it possible to machine up to 5-axis. Various types of products can be machined

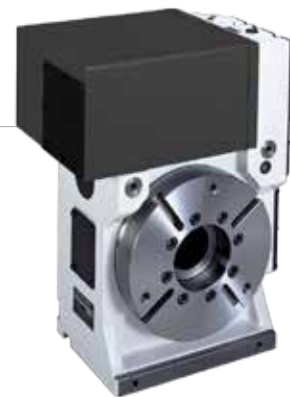

Environment Device

Mist Collector

Mist Collector reduces the amount of smoke and oil mist in the air. This helps build a safe and comfortable working environment and improve durability.



6PPL

6PPL contains 5 buffer stations and a setup station as standard. Compared to conventional machines that feature APC (2 Pallets), 6PPL runs automatically for longer time. Also, machining various products is possible under a scheduled operation.



Chip Conveyor



Timely and effective disposal of chips will enhance productivity as well as the working environment.

- **Hinge Belt Type** : Highly efficient when disposing a lot of chips. Capable of handling stringy chips. **(Long Chip)**
- **Scraper Type** : Convenient for shortly cut chips. **(Short Chip)**
- **Drum Filter Type** : Advantageous in precision, as the chips do not flow in to the coolant nozzle. **(AL Chip)**



Cabin Screw Chip Conveyor (Standard)

Dual screw type chip conveyors are located at each side of the bed making it convenient to remove chips.

SPECIFICATIONS

Standard & Optional

Spindle		KH50G	KH63G
4,500rpm (18.5/15kW [24.8/20.1HP])	FANUC	●	-
4,500rpm (22/18.5kW [29.5/24.8HP])	FANUC	○	●
4,500rpm (26/22kW [34.9/29.5HP])	FANUC	-	○
4,500rpm (18/15kW [24.1/20.1HP])	HYUNDAI-ITROL	○	-
4,500rpm (22.2/18.5kW [29.8/24.8HP])	HYUNDAI-ITROL	-	○
8,000rpm (18/15kW [24.1/20.1HP])	HYUNDAI-ITROL	○	-
8,000rpm (22.2/18.5kW [29.8/24.8HP])	HYUNDAI-ITROL	-	○
8,000rpm (18.5/15kW [24.8/20.1HP])	FANUC	○	-
8,000rpm (22/15kW [29.5/20.1HP])	FANUC	○	-
8,000rpm (22/18.5kW [29.5/24.8HP])	FANUC	-	○
8,000rpm (26/18.5kW [34.9/24.8HP])	FANUC	-	○
Spindle Cooling System		●	●
ATC			
ATC Extension	40	●	●
	60	○	○
	90	○	○
	120	○	○
Tool Shank Type	BT50	●	●
	BBT50	○	○
	CAT50/BCV50	○	○
Heavy Weight Tool	20kg (44lb)	●	●
	35kg (77lb)	○	○
U-Center	D'andrea	○	○
Pull Stud	45°	○	○
	60°	○	○
	90°	●	●
Servo Motor Magazine		○	○
Table & Column			
APC	Shuttle	●	●
Tap Type Pallet		●	●
T-Slot Pallet		○	○
Std. Table	1°	●	●
B Axis T/C Table	0.001°	○	○
Coolant System			
Std. Coolant (Nozzle)		●	●
Through spindle coolant*	20 bar (290 psi)	○	○
	30 bar (435 psi)	○	○
	70 bar (1,015 psi)	○	○
Shower Coolant		○	○
Gun Coolant		○	○
Side Oil Hole Coolant		☆	☆
Air Gun		○	○
Cutting Air Blow		○	○
Tool Measuring Air Blow (Only for TLM)		○	○
Air Blow for Automation		☆	☆
Thru MQL Device (Without MQL)		☆	☆
Coolant Chiller		☆	☆
Power Coolant System (For Automation)		☆	☆
Chip Disposal			
Coolant Tank	400ℓ (105.7 gal)	●	●
Cabin Screw Chip Conveyor		●	●
Chip Conveyor (Hinge/Scraper)	Left(Front) Left(Rear)	○	○
Special Chip Conveyor (Drum Filter)		☆	☆
Chip Wagon	Standard (180ℓ [47.5 gal])	○	○
	Swing (200ℓ [52.8 gal])	○	○
	Large Swing (290ℓ [76.6 gal])	○	○
	Large Size (330ℓ [87.2 gal])	○	○
	Customized	☆	☆
S/W			
Machine guidance (HW-MCG)		●	●
Tool Monitoring (HW-TM) : FANUC/ITROL		○/●	○/●

Through Spindle Coolant* : Please check the filter types with sales representative.
Specifications are subject to change without notice for improvement.

● : Standard ○ : Option ☆ : Prior Consultation - : Non Applicable

DNC Software (HW-eDNC)		○	○
Spindle Heat Distortion Compensation (HW-TDC)		○	○
S/W		KH50G	KH63G
Spindle Warm up Function (HW-WARMUP)		●	●
Energy Saving System (HW-ESS)		●	●
Machine Monitoring System (HW-MMS)		○	○
RENISHAW GUI		○	○
Machining Condition Selection (HW-MCS)		●	●
Adaptive Feed Control (HW-AFC)		●	●
Conversational Program (HW-DPRO)		○	○
Safety Device			
Total Splash Guard		●	●
APC Splash Guard		○	○
Electric Device			
Call Light	1 Color : ●	●	●
Call Light	2 Color : ●●	○	○
Call Light	3 Color : ●●●	○	○
Call Light & Buzzer	3 Color : ●●● B	○	○
Work Light		●	●
Electric Cabinet Light		○	○
Remote MPG		●	●
3 Axis MPG		○	○
Work Counter	Digital	○	○
Total Counter	Digital	○	○
Tool Counter	Digital	○	○
Multi Tool Counter	6 EA	○	○
	9 EA	○	○
Electric Circuit Breaker		○	○
AVR (Auto Voltage Regulator)		☆	☆
Transformer	35kVA	○	○
Auto Power Off		○	○
Back up Module for Black out		○	○
Back up Module for Black out - Extension (FANUC : PFB-R/C)		○	○
Measuring Device			
Air Zero	TACO	☆	☆
	SMC	☆	☆
Work Measuring Device		○	○
TLM (Marposs/Renishaw/Blum)	Touch	○	○
	Laser	○	○
Tool Broken Detective Device		○	○
Linear Scale	X/Y/Z Axis	○	○
Rotary Scale	B Axis	○	○
Pallet Close Confirmation Device		○	○
Coolant Level Sensor (Only for Chip Conveyor, Bladder Type)		☆	☆
Environment			
Air Conditioner		○	○
Dehumidifier		○	○
Oil Mist Collector		☆	☆
Oil Skimmer (Only for Chip Conveyor)		○	○
MQL (Minimal Quantity Lubrication)		☆	☆
Fixture & Automation			
Auto Door	Std.	-	-
	High Speed	-	-
Auto Shutter (Only for Automatic System)		-	-
Sub O/P		☆	☆
Control of Additional Axis	1Axis / Pallet	☆	☆
	2Axis / Pallet	-	-
External M Code 4ea		○	○
Automation Interface		☆	☆
I/O Extension (In & Out)	16Contact	○	○
	32Contact	○	○
PPL (6PPL)		○	○
Hyd. Device			
Std. Hyd. Unit	45bar (652.7 psi) / 60ℓ (16.9 gal)	●	●
	70 bar (1,015 psi) / 100ℓ (26.4 gal)	-	-
Center Type Hyd. Supply Unit (Upper)	2x4(8Port)	○	○
Manual Coupler	2x2(4Port)	☆	☆
Auto Coupler		☆	☆
Hyd. Unit for Fixture	45bar (653psi)	○	○
	70bar (1,015psi)	○	○
	100bar (1,450 psi)	○	○
	Customized	☆	☆
ETC			
Tool Box		●	●
Customized Color	Need for Munsel No.	☆	☆
CAD/CAM Software		☆	☆
Air Lift Slide Method	Z Axis	●	●

SPECIFICATIONS

External Dimensions

unit : mm(in)

KH50G

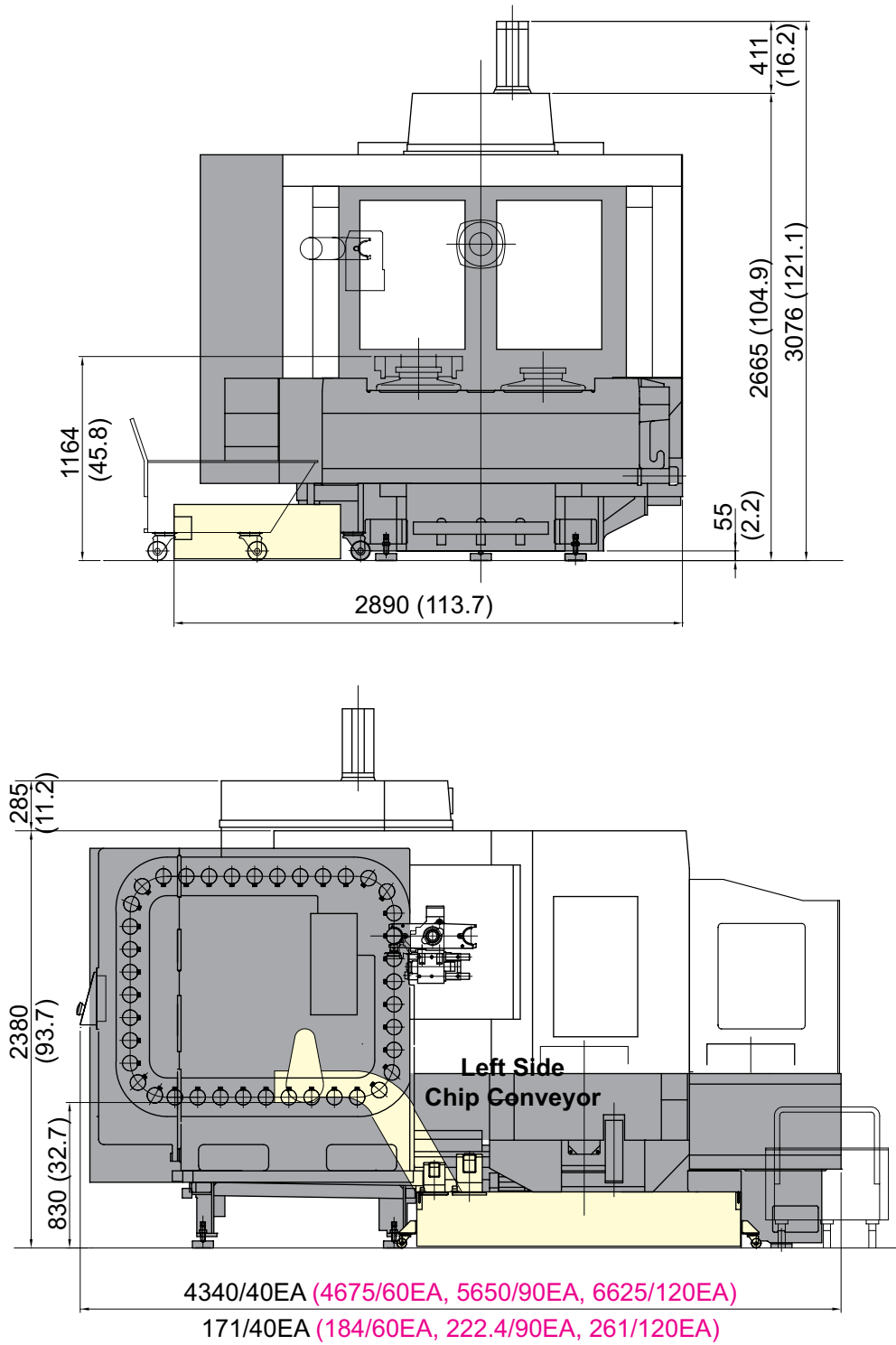

SPECIFICATIONS

External Dimensions

unit : mm(in)

KH63G

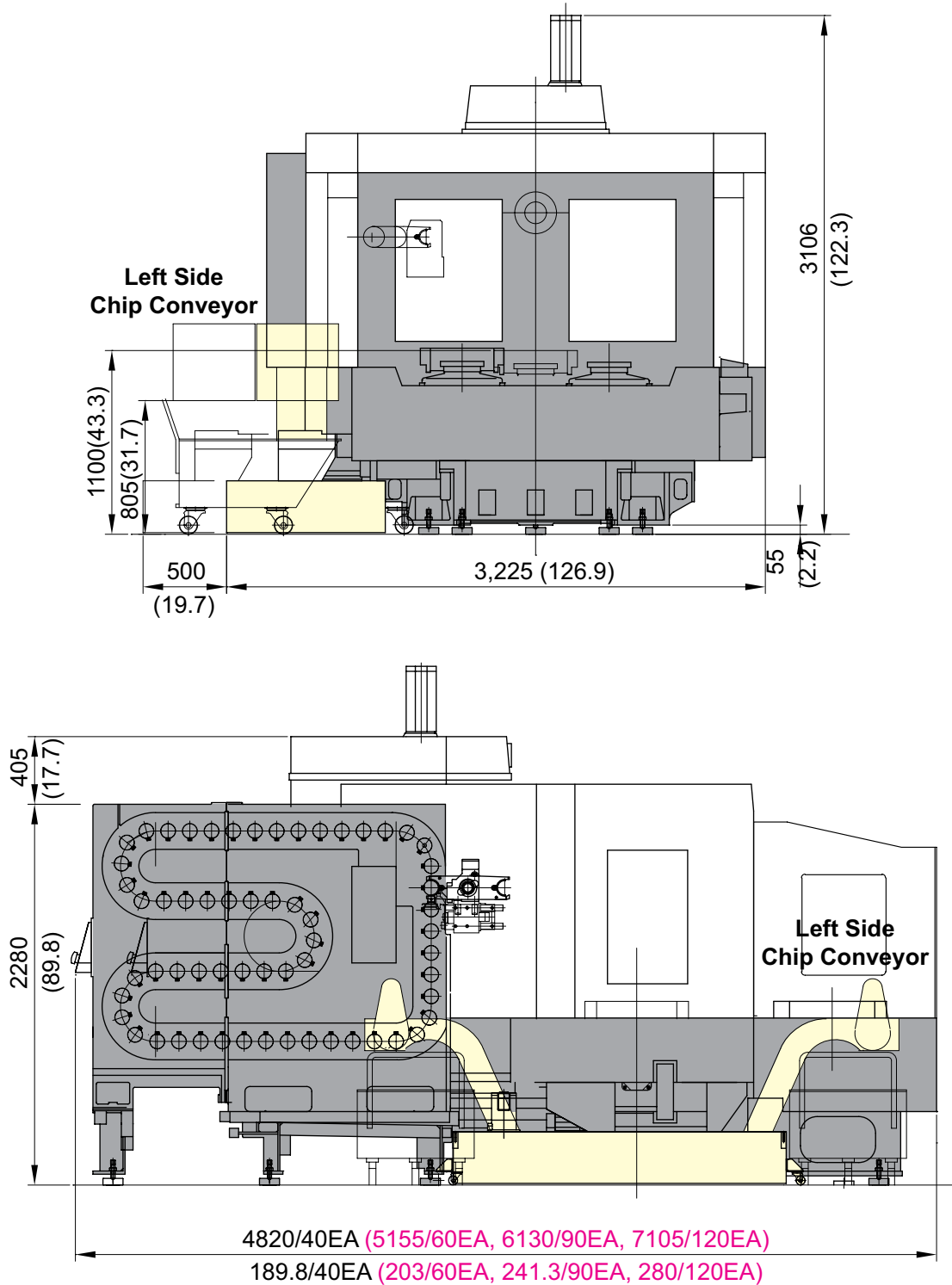

SPECIFICATIONS

Table Dimensions

unit : mm(in)

KH50G

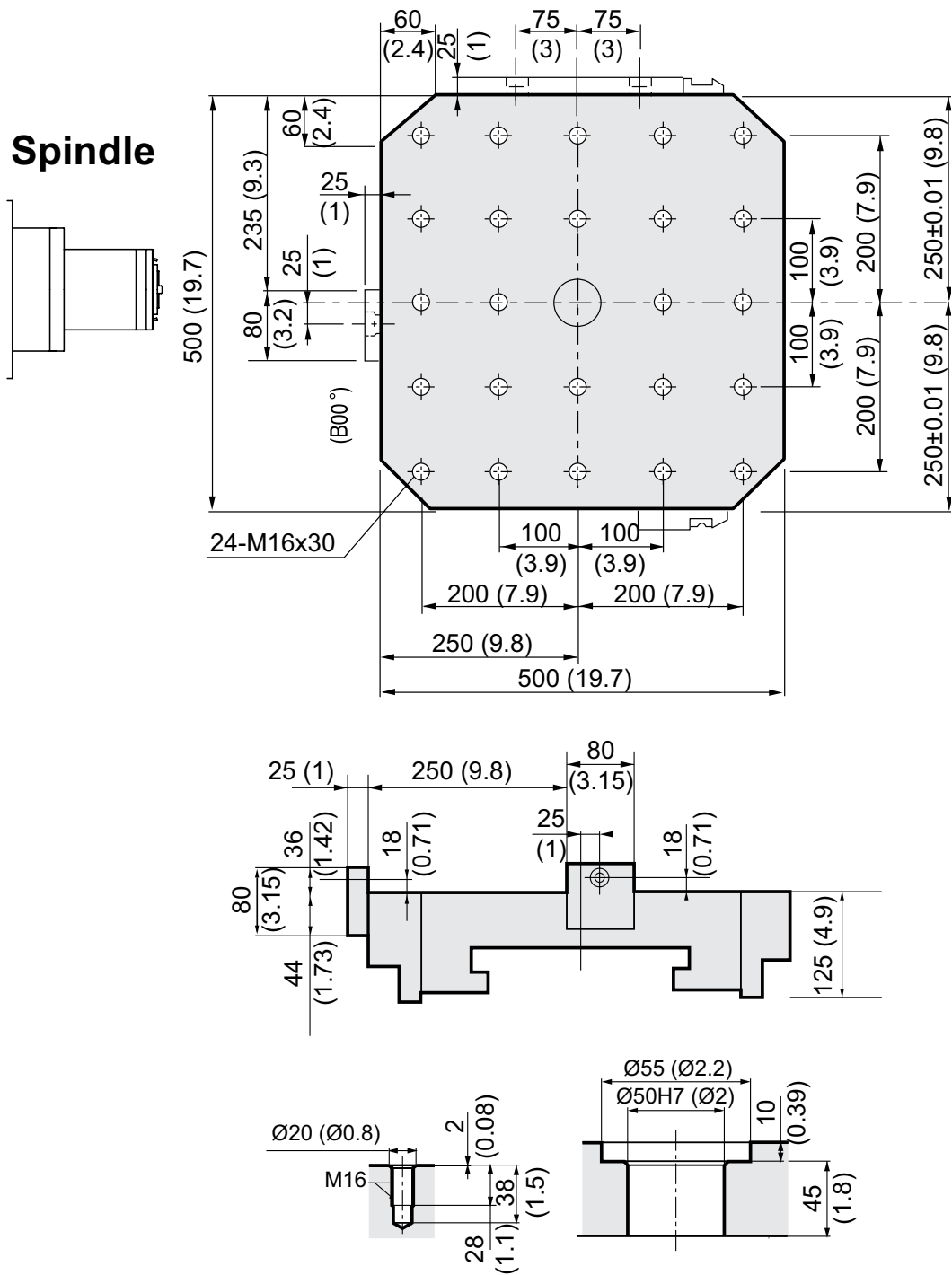

SPECIFICATIONS

Tool Shank

unit : mm(in)

BT50

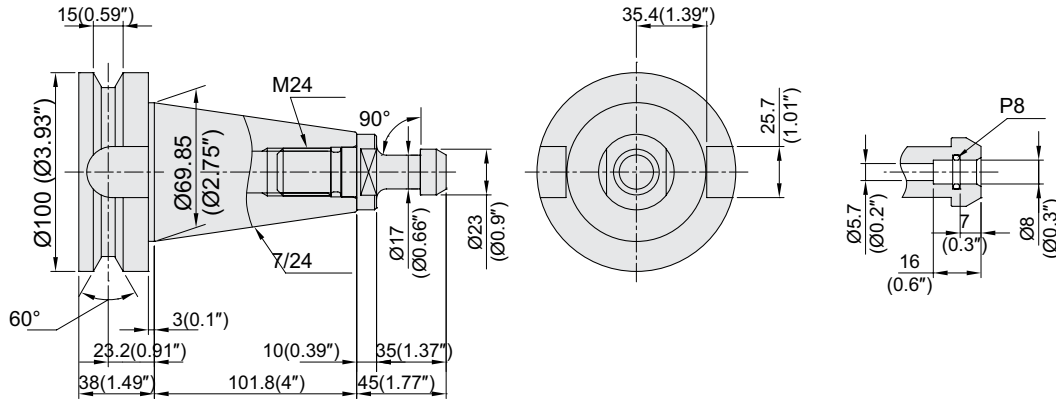

BBT50, BIG PLUS

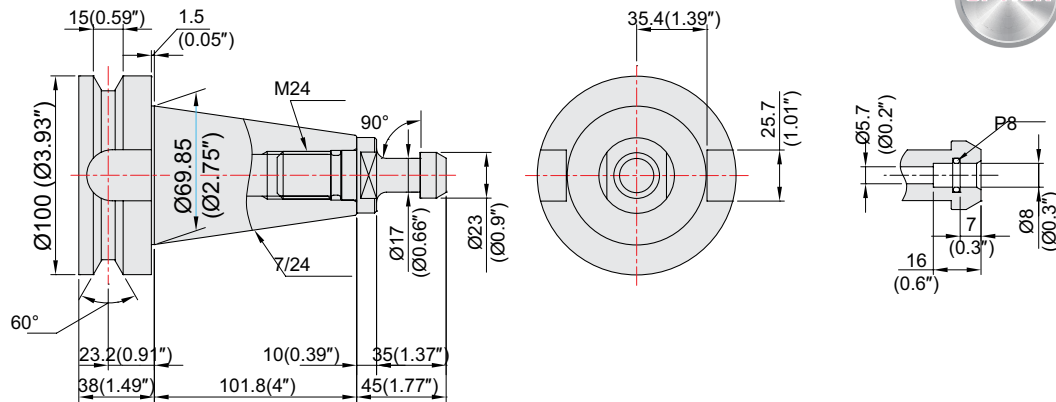

CAT-50

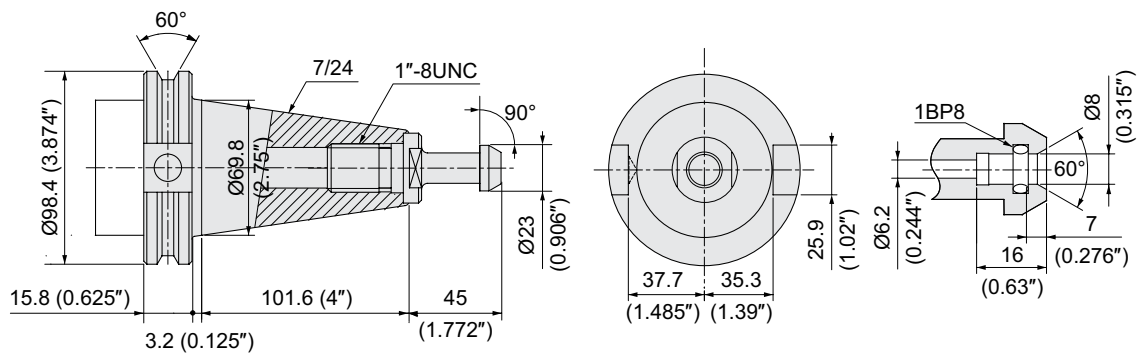

PULL STUD DEGREE : 90° (Std.) / 45°, 60° (Opt.)

SPECIFICATIONS

Specifications

[] : Option

ITEM		KH50G	
PALLET	Pallet Size	mm(in)	500×500 (19.7"×19.7")
	Maximum Load Capacity	kgf(lbf)	2-800 (2-1,764)
	Maximum Working Size	mm(in)	Ø900×H780 (Ø35.4"×H30.7")
	Min. Indexing Angle	deg	1° [0.001°]
SPINDLE	Spindle Taper	-	NT #50
	Spindle RPM	r/min	4,500 [4,500] [8,000] [8,000] [4,500] [8,000]
	Spindle Motor Output (Max./Cont.)	kW(HP)	18.5/15 (24.8/20.1) [22/15 (29.5/20.1)] [18.5/15 (24.8/20.1)] [22/15 (29.5/20.1)] [18/15 (24.1/20.1)] [18/15 (24.1/20.1)]
	Spindle Torque (Max./Cont.)	N·m(lbf.ft)	901/730 (664.5/538.4) [1,071/730 (789.9/538.4)] [657/532 (484.6/392.4)] [781/532 (576/392.4)] [1,150.3/966.3 (848.4/712.7)] [837.1/703.1(617.4/518.6)]
	Spindle Driving Method	-	2 STEP GEAR
FEED	Travel (X/Y/Z axis)	mm(in)	760/705/650 (29.9"/27.8"/25.6")
	Distance from Table Top to Spindle Center	mm(in)	0~705 (0"~27.8")
	Distance from Table Center to Spindle Nose	mm(in)	135~785 (5.3"~30.9")
	Rapid Traverse Rate (X/Y/Z)	m/min(ipm)	20/20/20 (787/787/787)
	Slide Type	-	BOX GUIDE
ATC	Number of Tools	EA	40 [60, 90, 120]
	Tool Shank	-	BT50 [BBT50] [CAT50] [BCV50]
	Max. Tool Dia. (W.T/W.O)	mm(in)	Ø110/Ø245 (Ø4.3"/Ø9.6")
	Max. Tool Length	mm(in)	400 (15.7")
	Max. Tool Weight	kg(lb)	20 (44) [35 (77)]
	Tool Selection Method	-	FIXED ADDRESS
	Tool Change Time	T-T	sec
C-C		sec	11
APC	No. of Pallet	EA	2 [6]
	Pallet Change Time	sec	26
	APC Type	-	SHUTTLE
TANK CAPACITY	Coolant Tank	ℓ (gal)	400 (105.7)
	Lubricating Tank	ℓ (gal)	3 (0.8)
	Hyd. Tank Unit	ℓ (gal)	60 (15.9)
POWER SUPPLY	Air Consumption (0.5MPa)	ℓ /min(gal/min)	300 (79.2)
	Electric Power Supply	KVA	33
	Thickness of Power Cable	Sq	Over 25
	Voltage	V/Hz	220/60 (200/50*)
MACHINE	Floor Space (L×W)	mm(in)	3,530×4,815 (139"×189.6")
	Height	mm(in)	3,076 (121.1")
	Weight	kg(lb)	12,000 (26,455)
PC	Controller	-	FANUC 31i-B [HYUNDAI-ITROL]

*) Using 50Hz voltage instead of 60Hz may lower the output of motors. (excluding servo motors and inverter motors)
Specifications are subject to change without notice for improvement.

SPECIFICATIONS

Specifications

[] : Option

ITEM		KH63G	
PALLET	Pallet Size	mm(in)	630×630 (24.8"×24.8")
	Maximum Load Capacity	kgf(lbf)	2-1,000 (2-2,205)
	Maximum Working Size	mm(in)	Ø1,120×H875 (Ø44.1"×H34.4")
	Min. Indexing Angle	deg	1° [0.001°]
SPINDLE	Spindle Taper	-	NT #50
	Spindle RPM	r/min	4,500 [4,500] [8,000] [8,000] [4,500] [8,000]
	Spindle Motor Output (Max./Cont.)	kW(HP)	22/18.5 (29.5/24.8) [26/18.5 (34.9/24.8)] [22/18.5 (29.5/24.8)] [26/18.5 (34.9/24.8)] [22.2/18.5 (29.8/24.8)] [22.2/18.5 (29.8/24.8)]
	Spindle Torque (Max./Cont.)	N·m(lbf.ft)	1,071/901 (789.9/664.5) [1,267/901 (934.5/664.5)] [781/657 (576/484.6)] [922/657 (680/484.6)] [1,390.3/1,202.5 (1,025.4/886.9)] [1,011.7/875 (746.2/645.4)]
	Spindle Driving Method	-	2 STEP GEAR
FEED	Travel (X/Y/Z axis)	mm(in)	950/825/760 (37.4"/32.5"/29.9")
	Distance from Table Top to Spindle Center	mm(in)	0~825 (0"~32.5")
	Distance from Table Center to Spindle Nose	mm(in)	175~935 (6.9"~36.8")
	Rapid Traverse Rate (X/Y/Z)	m/min(ipm)	20/20/20 (787/787/787)
	Slide Type	-	BOX GUIDE
ATC	Number of Tools	EA	40 [60, 90, 120]
	Tool Shank	-	BT50 [BBT50] [CAT50] [BCV50]
	Max. Tool Dia. (W.T/W.O)	mm(in)	Ø110/Ø245 (Ø4.3"/Ø9.6")
	Max. Tool Length	mm(in)	600 (23.6")
	Max. Tool Weight	kg(lb)	20 (44) [35 (77)]
	Tool Selection Method	-	FIXED ADDRESS
	Tool Change Time	T-T C-C	sec sec
APC	No. of Pallet	EA	2 [6]
	Pallet Change Time	sec	26
	APC Type	-	SHUTTLE
TANK CAPACITY	Coolant Tank	ℓ (gal)	400 (105.7)
	Lubricating Tank	ℓ (gal)	3 (0.8)
	Hyd. Tank Unit	ℓ (gal)	60 (15.9)
POWER SUPPLY	Air Consumption (0.5MPa)	ℓ /min(gal/min)	300 (79.2)
	Electric Power Supply	KVA	36
	Thickness of Power Cable	Sq	Over 25
	Voltage	V/Hz	220/60 (200/50*)
MACHINE	Floor Space (L×W)	mm(in)	3,530×5,320 (139"×209.4")
	Height	mm(in)	3,106 (122.3")
	Weight	kg(lb)	14,000 (30,865)
NC	Controller	-	FANUC 31i-B [HYUNDAI-ITROL]

*) Using 50Hz voltage instead of 60Hz may lower the output of motors. (excluding servo motors and inverter motors)
Specifications are subject to change without notice for improvement.

CONTROLLER

FANUC 31i-B

[] : Option ☆ Needed technical consultation

Controlled axis / Display / Accuracy compensation	
Control axes	3 axes (X, Y, Z) 4 axes (X, Y, Z, B)
Simultaneously controlled axes	3 axes [Max. 4 axes]
Least setting Unit	X, Y, Z axes : 0.001 mm (0.0001 inch) B axes : 0.001 deg
Least input increment	X, Y, Z axes : 0.001 mm (0.0001 inch) B axes : 0.001 deg
Inch / Metric conversion	G20 / G21
High response vector control	
Interlock	All axes / Each axis
Machine lock	All axes
Backlash compensation	± 0 ~ 9999 pulses (Rapid traverse / Cutting feed)
Position switch	
LCD / MDI	10.4 inch color LCD
Feedback	Absolute motor feedback
Stored stroke check 1	Over travel
Stored pitch error compensation	
Operation	
Automatic operation (Memory)	
MDI operation	
DNC operation	Needed DNC software / CF card
Program restart	
Wrong operation prevention	
Program check function	Dry run, Program check Z axes Machine lock, Stroke check before move
Single block	
Search function	Program Number / Sequence Number
Interpolation functions	
Nano interpolation	
Positioning	G00
Linear interpolation	G01
Cylindrical interpolation	G02, G03
Exact stop mode	Single : G09, Continuous : G61
Dwell	G04, 0 ~ 9999.999 sec
Skip	G31
Reference position return	1st reference : G28 2nd reference : G27 Ref. position check : G30
Thread synchronous cutting	G33
Helical interpolation	Circular + Linear interpolation 2 axes(max.)
Feed function / Acc. & Dec. control	
Manual feed	Rapid traverse Jog : 0~5,000mm/min (197 ipm) Manual handle : x1, x10, x100 pulses Reference position return
Cutting feed command	Direct input F code
Feedrate override	0 ~ 200% (10% Unit)
Rapid traverse override	F0% (F1%), F25%, F50%, F100%
Override cancel	
Feed per minute	G94
Feed per revolution	G95
Look-ahead block	40 Block 200 Block (Mold)
Program input	
Tape Code	EIA / ISO
Optional block skip	1 ea
Absolute / Incremental program	G90 / G91
Program stop / end	M00, M01 / M02, M30
Maximum command unit	± 999,999.999 mm (± 99,999.9999 inch)
Plane selection	X-Y : G17 / Z-X : G18 / Y-Z : G19
Workpiece coordinate system	G52, G53, 48 pairs (G54.1 P1 ~ 48)
Manual absolute	Fixed ON
Programmable data input	G10
Sub program call	10 folds nested
Custom macro	#100 ~ #149, #500 ~ #549
G code system	A
Programmable mirror image	G51.1, G50.1
G code preventing buffering	G4.1
Including Chamfering / Corner R	
Canned cycle	G73, G74, G76, G80 ~ G89
Coordinate rotation	G68, G69

Auxiliary function / Spindle speed function	
Auxiliary function	M 4 digit
Level-up M Code	Multi / Bypass M code
Spindle speed command	S 5 digit , Binary output
Spindle override	0% ~ 150% (10% Unit)
Spindle orientation	M19
FSSB high speed rigid tapping	
Tool function / Tool compensation	
Tool function	Max. T 8 digit
Tool life management	256 pairs ☆
Tool offset pairs	99 pairs
Tool nose radius compensation	G40, G41, G42
Tool nose length compensation	G43, G44, G49
Tool offset memory C	Tool length, diameter, abrasion(length, diameter)
Tool length measurement	Z axes Input C
Editing function	
Part program storage size	640m (256KB)
No. of registerable programs	500 EA
Program protect	
Background editing	
Extended part program editing	Copy, move and change of NC program
Memory card program edit	
Data input / output & Interface	
I/O interface	RS 232C serial port, CF card, USB memory Embedded Ethernet interface
Screen hard copy	
External message	
External key input	
External workpiece number search	
Automatic data backup	
Setting, display and diagnosis	
Self-diagnosis function	
History display	Alarm & Operator message & Operation
Run hour / Parts count display	
Maintenance information	
Actual cutting feedrate display	
Display of spindle speed / T code	
Graphic display	
Operating monitor screen	Spindle / Servo load etc.
Power consumption monitoring	Spindle & Servo
Spindle / Servo setting screen	
Multi language display	Support 20 languages
Display language switching	Selection of 5 optional Languages
LCD Screen Saver	Screen saver
Processing select	Speed/rigidity setting
Option	
Additional optional block skip	9 ea ☆
Fast ethernet	Needed option board
Data server	Needed option board
Protection of data at 8 levels	
Sub Spindle control	
Polar coordinate command	G15, G16
Polar coordinate interpolation	G12.1, G13.1
Cylindrical interpolation	G07.1
One-way positioning	G60
Stored stroke check 2, 3	
Inverse-time feed	G93
Scaling	G50, G51
Manual guide i	Conversational auto program
Handle interrupt	
Manual handle feed	2/3 units
Additional custom macro variables	#100~#199, #500~#999
Retraction for rigid tapping	#100~#199, #500~#999, #98000~#98499
Tool management function	
Tool offset number	Max. 2000 pair ☆
Program storage capacity	512KB ~ 8MB ☆
Program registration number	Max. 4000 ea ☆
Additional work coordinate	Max. 300 pair (G54.1 P1 ~ P300)
AICC II	200 block 400 / 600 / 1000 block ☆

Figures in inch are converted from metric values.

The FANUC controller specifications are subject to change based on the policy of company CNC supplying.

CONTROLLER

HYUNDAI-iTROL

Control & Composition	
Number of axis/Spindles	3 axis (X, Y, Z)
Number of axis/Spindles, max.	6 axis (Axis + Spindle)
Color display	TFT 10.4" Color (800 x 600)
Keyboard	QWERTY Full Keyboard
Part program	1MB, 3MB, 5MB
Addition of part program on CF card	
Transfer Function	
Feedrate override	0% ~ 200%
Transfer value input range	± 999999999
Unlimited rotation of rotation axis	
Acc./Dec. with jerk limitation	
Measuring systems 1 and 2, selectable	
Travel to fixed stop	
Auto servo drive tuning	
Spindle Function	
Spindle override	0% ~ 150%
Spindle speed, max. programmable value ange	1000000 ~ 0.0001
Automatic gear stage selection	
Spindle orientation	
Spindle speed limitation	
Rigid tapping	
Interpolation	
Linear interpolation axis, max.	4 axis
Circle via center point and end point	
Circle via interpolation point	
Helical interpolation	
Non-uniform rational B splines	
Compressor for 3-axis machining	
Advanced surface	
Program Function	
Subroutine levels, max.	11
Interrupt routines, max.	4
Number of levels for skip blocks	2
Polar Coordinates	
Dimensions inch/metric, changeover manually or via program	
Dynamic preprocessing memory FIFO	
Look ahead	50, 100, 150
Absolute/Incremental command	G90 / G91
Scaling/Rotation	
Read/Write system variables	
Block search	
Edit background	
Processing program number, max.	750
Using of CF Card, USB	
Basic coordinate number, max.	1
Work coordinate number, max.	100
Basic/Work coordinate programming change	
Scratching function	
Global and Local user data (GUD/LUD)	
Global program user data	
Interactive cycle program	
Tool Function	
Tool radius compensations	
Tool offset selection via T/D numbers	
Tools / Cutting edges in tool list	80/160, 128/256, 256/512
Monitoring Function	
Working area limit	
Software and Hardware limit	
Zero-speed/Clamping monitoring	
2D/3D protection zones	
Contour monitoring	
Compensation	
Backlash compensation	
Leadscrew error compensation	
Measuring system error compensation	
Feedforward control (Speed control)	
Safety Function	
Safe torque off (STO)	
Safe brake control (SBC)	
Safe stop 1 (SS1)	
Diagnostic Function	
Alarm/Message, Alarm log	
PLC status/LAD online display	
PLC remote connection (Ethernet)	
Automation Support Function	
Actual velocity display	
Tool life management	As time / As amount
Work counter/Cycle time	Embedded
2D simulation	
Manual Operation	
Manual handle/Jog transfer	
Manual measurement of workpiece / tool offset	
Automatic tool/Workpiece measurement	
Automatic/Program reference approach	
Automatic Operation	
Program run as using CF card/USB	
Program control/modification	
Block search	
Reposition	
Preset (Set actual value)	
Data Transmission	
Ethernet network	
USB memory stick & CF card	
Convenience Function	
Processing setting	Coordinate setting, Auto tool length measurement
Processing support	Tool Monitoring, Spindle overload monitoring
Maintenance	Turret Guidance, I/O monitoring, Manual
Maintenance / Management	Soft MCP, Spindle warming-up M/G code list
SMART machining	
Energy saving function (ECO)	
Machine Monitoring System (MMS Lite)	
Language	
Standard support language	Chinese Simplified, English, Korean
Option	
Maximum skip block number	10
DRF offset	
MDI program save/load	
Teach-In mode	
3D simulation	Except for working area/Collision check
Real time simulation	
Shop Mill	Conversational Program
Spline interpolation	
Program remote control in network	
Language	Chinese Traditional, French, German, Italian, Portuguese, Spanish

Figures in inch are converted from metric values.
Specifications are subject to change without notice for improvement.

GLOBAL NETWORK

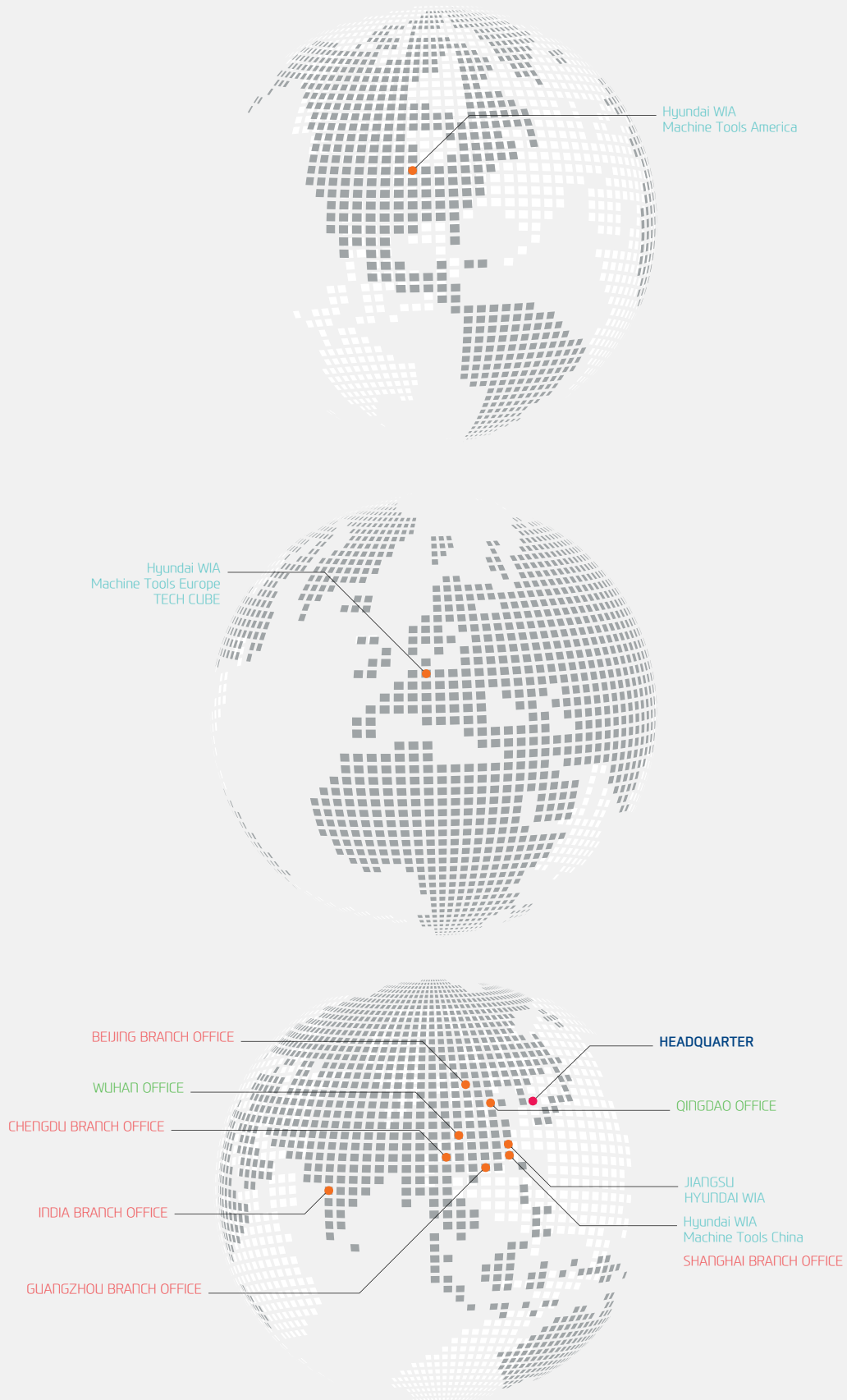

GLOBAL NETWORK



HEADQUARTER

Changwon Technical Center / R&D Center / Factory

153, Jeongdong-ro, Seongsan-gu, Changwon-si,
Gyeongsangnam-do, Korea (Zip Code : 51533)
TEL : +82 55 280 9114 FAX : +82 55 282 9680

Uiwang Technical Center / R&D Center

37, Cheoldobangmulgwan-ro, Uiwang-si, Gyeonggi-do,
Korea (Zip Code : 16082)
TEL : +82 31 596 8213 Fax : +82 55 210 9804

OVERSEAS OFFICES

HYUNDAI WIA Machine Tools America

450 Commerce Blvd. Carlstadt, NJ 07072
TEL : +1 630 625 5600

Jiangsu HYUNDAI WIA

Company No.6 Fenghuang Road,
Fenghuang Town, Zhangjjagang City,
Jiangsu province, China
TEL : +86 512 5672 6808
FAX : +86 512 5671 6960

Chengdu Branch Office

NO.508 Room, B Block, AFC Plaza, NO.88
Jiaozi Road, High-tech Zone, Chengdu,
China
TEL : +86 028 8665 2985
FAX : +86 028 8665 2985

HYUNDAI WIA Machine Tools Europe TECH CUBE

Alexander-Fleming-Ring 57, 65428
Rüsselsheim Germany
TEL: +49 6142 9256 0
FAX: +49 6142 9256 100

Hyundai WIA Machine Tools China Shanghai Branch Office

2-3F, Bldg6, No.1535 Hongmei Road,
Xuhui District, Shanghai, China
TEL : +86 021 6427 9885
FAX : +86 021 6427 9890

Qingdao Office

Room 1207, Cai Fu Building, 182-6 Haier
Middle Road, Qingdao, China
TEL : +86 0532 8667 9334
FAX : +86 0532 8667 9338

India Branch Office

#4/169, Rajiv Gandhi Salai, (OMR),
Kandanchavadi, Chennai-600 096,
Tamilnadu, India
TEL: +91-44-3290-1719

Beijing Branch Office

Floor 14, Zhonghangji Plaza B, No.15
Ronghua South Road, BDA Dist., Daxing
Dist., Beijing, China 100176
TEL : +86 010 8453 9850
FAX : +86 010 8453 9853

Wuhan Office

Room 302, B Tower, Nova Center,
Dongfeng Three Road, Zhuankou,
Wuhan, Hubei, China
TEL : +86 027 5952 3256
FAX : +86 027 5952 3256

Guangzhou Branch Office

Room 311, Unit 1-3, POLY TAL TU WUP,
Hanxi Avenue, Panyu District,
Guangzhou, China
TEL : +86 020 8550 6595
FAX : +86 020 8550 6597



KH63G Movie



<http://machine.hyundai-wia.com>

Head Office & Factory

153, Jeongdong-ro, Seongsan-gu, Changwon-si, Gyeongsangnam-do **Tel** +82 55 280 9500

Overseas Sales Team

16F, 37, Cheoldobangmulgwan-ro, Uiwang-si, Gyeonggi-do **Tel** +82 31 596 8213

HYUNDAI WIA Machine Tools America

450 Commerce Blvd. Carlstadt, NJ 07072 **Tel** +1 (630) 625 5600

HYUNDAI WIA Machine Tools Europe TECH CUBE

Alexander-Fleming-Ring 57, 65428 Rüsselsheim Germany **Tel** +49 6142 9256 0 **Fax** +49 6142 9256 100

India Branch Office

#4/169, Rajiv Gandhi Salai, (OMR), Kandanchavadi, Chennai-600 096, Tamilnadu, India **Tel** +91 44 3290 1719