

KBN

135 Series

KBN135 | KBN135C

HYUNDAI WIA Heavy Duty Boring Machine

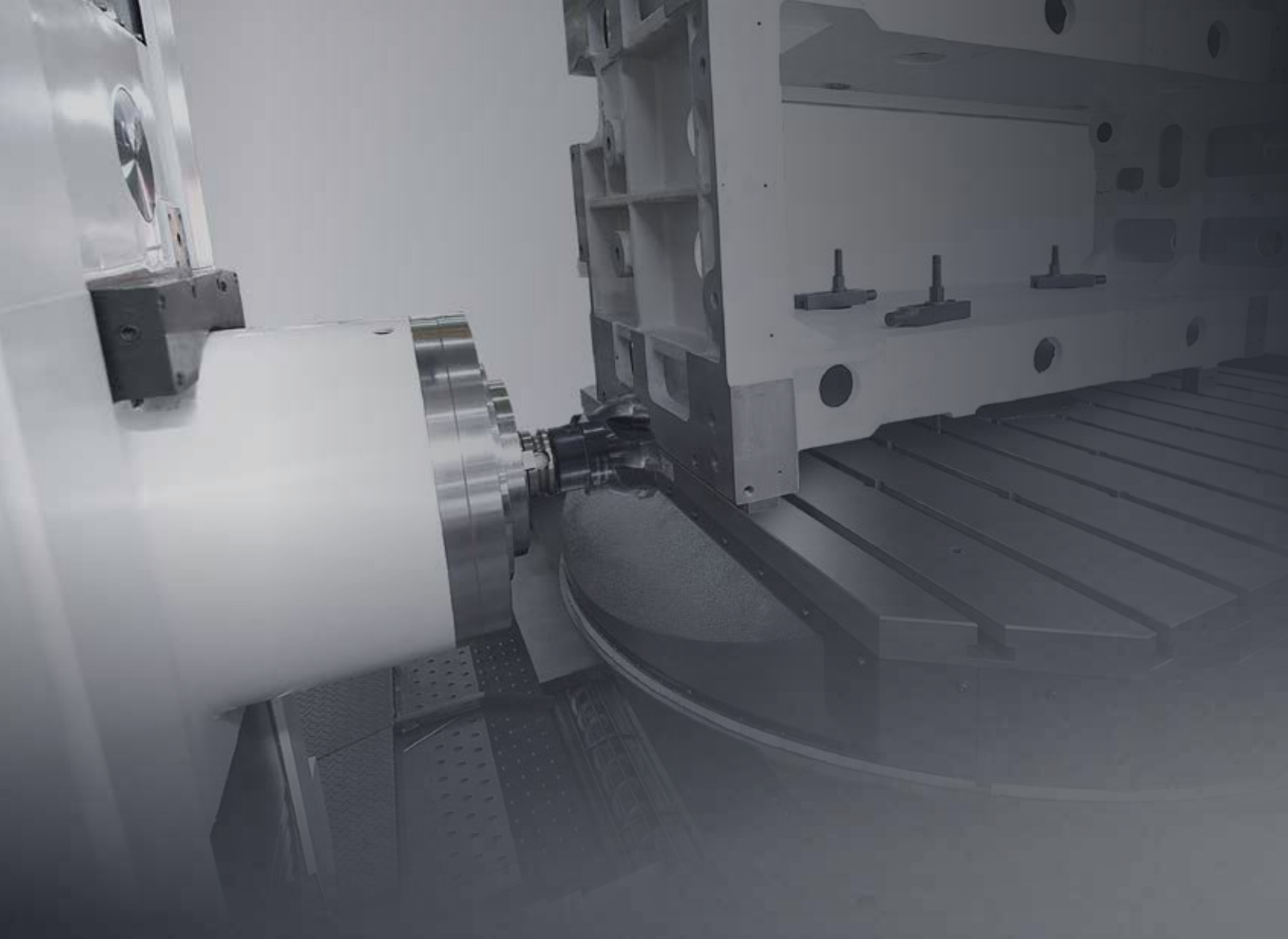

Technical Leader

The Heavy Duty Boring Machine KBN135/KBN135C, designed by Hyundai WIA with years of expertise and the latest technology, provides high performance and maximum productivity.

		KBN135	KBN135C
Pallet Size (L×W)	mm(in)	2,000×1,800	2,000×1,800
Max. Load Capacity	kg(lb)	10,000	15,000 [20,000]
Min. Indexing Angle	deg	0.001° / 90° (LOCATING PIN)	
Spindle Quill Dia.	mm(in)	Ø135	
Spindle Taper	-	NT #50	
Spindle Speed	r/min	2,000 [2,000] [2,000]	2,500 [2,500] [2,500] [2,500]
Spindle Power	kW (HP)	22 (30) [26 (35)] [37 (50)]	22 (30) [26 (35)] [37 (50)] [37 (50)]
Spindle Driving Method	-	3 Step Gear	
No. of Tools	EA	40 [60, 90, 120]	40 [60]
Travel (X/Y/Z/W)	mm(in)	3,000/2,000/1,600/700 (118.1"/78.7"/63"/27.6") [4,000/2,500/1,600/700 (157.5"/98.4"/63"/27.6")]	3,000/2,000/1,600/700 (118.1"/78.7"/63"/27.6") [4,000/2,500/2,000/700 (157.5"/98.4"/78.7"/27.6")]
Rapid Traverse Rate	m/min(ipm)	8/8/8/8 (315/315/315/315)	10/10/10/8 (394/394/394/315) [7/10/10/8 (276/394/394/315)]

[] : Option ● HYUNDAI-ITROL

KBN

135 Series

The Next Generation Boring Machine

- One-piece bed construction for ultra precision (KBN135)
- Movable column structure for high-load, heavy load and heavy duty cutting (KBN 135C)
- X/Y-axis expansion up to 1,000mm (39.4") and 500mm (19.7") respectively
- 3 step gear driven spindle for heavy duty cutting
- Optimal boring processing with W-axis travel of 700mm (27.6")
- Linear scale and rotary scale for ultra precision
- Position Encoder on B-axis for highly precise positioning



KBN135C

KBN135

01 BASIC FEATURES

The Most Advanced Mechanism, Revolutionized Productivity & High Performance

ATC & Magazine

- No. of Tools : 40EA [Opt. : 60EA]
- Tool Shank : BT50

NC Rotary Table

- Table Size : 2,000×1,800 mm
- Max. Load Capacity
 - KBN135 : 10,000 kg (22,046 lb)
 - KBN135C : 15,000 [20,000] kg
(33,069 lb [44,092 lb])
 - KBN135C Expand : 20,000 kg (44,092 lb)
- B-axis Built-in Position Encoder
- B-axis Spur Gear (KBN135C Series)

High Precision Spindle

- 3 Step Gear Type Spindle
- Cylindrical Roller Bearings
- 2,000 r/min [Opt. 2,500 r/min]
- W-axis 700 mm (27.6")

Convenient Maintenance

Oil and Air devices are located in front of the machine for easy repair and maintenance.

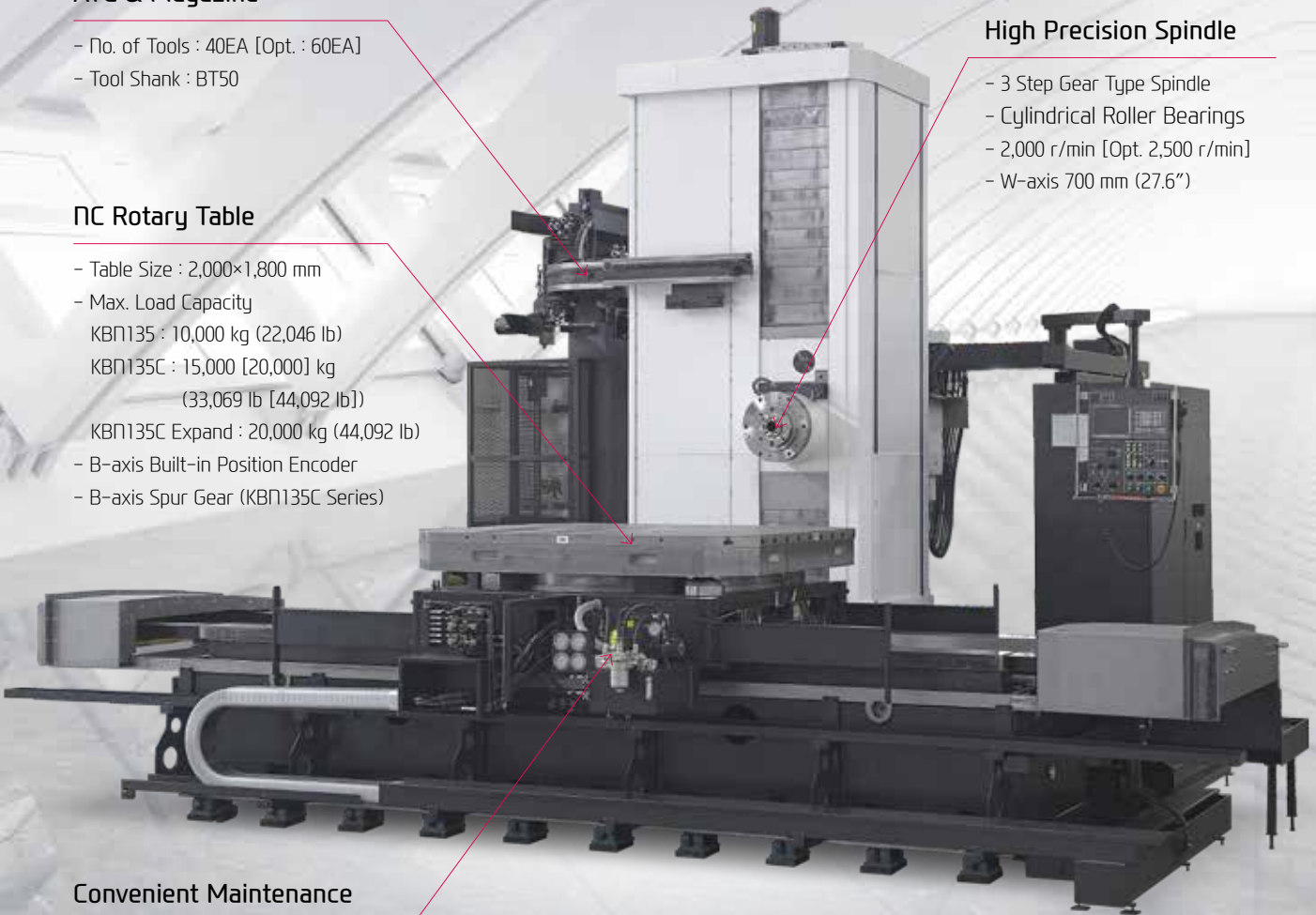

INCREASED RIGIDITY, OPTIMUM MACHINING CAPABILITY

HIGH RIGIDITY STRUCTURE

Column Moving Type - KBN135C

The column moving Z-axis enables precise machining of large work and prevents sagging of table when loading or machining.

Also, table column separate structure provides high rigidity.



Air Semi-Rising Slide Way

By applying the Air Semi-Rising Sliding Ways, the load on the X/Z-axis slideway is decreased. Therefore, positioning and repeatability accuracy can be maintained for a long time.



Fully Protected Slidecover

Slidecover of each axis is fully protected from chips and debris.



Table Moving Type - KBN135

The one-piece bed structure of X/Z-axis helps maintain high accuracy and makes it easier to adjust the machine for better precision.

HIGH PRECISION

Linear & Rotary Scales on All Axes

Linear scales on X/Y/Z-axis and rotary scale on B-axis provide High accuracy positioning and enabling precise machining.



02 HIGH PRECISION SPINDLE

Long Lasting, High Accuracy & Excellent Performance

Spindle Specifications

ITEM	Speed r/min	Power (Max./Cont.)	Torque (Max./Cont.)
KBN135	2,000 prm	22/18.5 kW (30/25 HP)	3,112/2,617 N·m
	Opt. 2,000 prm	26/22 kW (35/30 HP)	3,677/3,112 N·m
	Opt. 2,000 prm	37/30 kW (50/40 HP)	6,824/5,538 N·m
KBN135C	2,500 prm	22/18.5 kW (30/25 HP)	3,112/2,617 N·m
	Opt. 2,500 prm	26/22 kW (35/30 HP)	3,677/3,112 N·m
	Opt. 2,500 prm	37/30 kW (50/40 HP)	6,824/5,538 N·m
	Opt. 2,500 prm (ITROL)	37/31 kW (50/41.6 HP)	6,862/5,717 N·m

HEAVY DUTY CUTTING, 3-STEP GEAR TYPE SPINDLE

SPINDLE

Gear Type Spindle

By using ultra precision cylindrical roller bearings, fast acc/ deceleration of the spindle is achieved. The spindle head is designed to minimize the thermal displacement of the spindle, and with the use of a hydraulic tool locking system the machining stability is increased.

KBN135 series is designed with a 3 step gear driven spindle, providing high torque at low speed and stable machining at high speed.

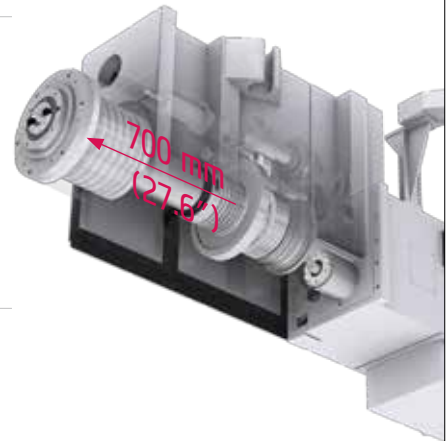

W-Axis Spindle

The W-axis travel of **700mm(27.6")** contributes to the KBN135 series reputation as among the very best boring machines.

Through Spindle Coolant **OPTION**

Through spindle coolant is particularly useful for deep hole drilling and helps increase tool life and decrease cycle time.



SPECIAL HEAD

OPTION

Angle Head (Manual)

Angle head comes with rotary body, which enables machining items that are set perpendicular to the spindle. It is connected to arbors that transfer the torque generated from the main spindle motors.

Angle Head Specifications

- Length : 500 mm (19.6"), 800 mm (31.5") - Angle : 90°, 180°, 270° or or any other customer needs



Facing Head (Manual)

A facing head is attached to the cross section of the spindle for various types of operations: outer facing, inner facing, cylindrical and conical boring and threading etc. It shows excellent performance in machining parts such as flange faces of large valves.



03 MAGAZINE & TABLE

High Productivity Achieved with High Rigidity, Accuracy Machining

ATC & Magazine Specifications

[] : Option

Model	No. of Tools	Max. Tool Dia. (W.T/W.O)	Max. Tool Length	Max. Tool Weight
KBN135	40 [60, 90, 120] EA	Ø1250/Ø25 mm (4.9"/9.8")	600 mm (23.6")	20 [30] kg (44.1 [66.1] lb)
KBN135C	40 [60] EA			

NC Rotary Table Specifications

Model	Table Size (L×W)	Max. Load Capacity	Min. Indexing Angle	B-axis Driven
KBN135	2,000×1,800 mm (78.7"×70.9")	10,000 kg (22,046 lb)	0.001° / 90° (Locating Pin)	Spur Gear
KBN135C		15,000 [20,000] kg (33,069 [44,092] lb)		

❖ KBN135C : within 300mm (11.8") of the biased weight
KBN135 : within 400mm (15.7") of the biased weight

HIGH RIGIDITY, TOOL CHANGE SYSTEM

ATC & MAGAZINE

Magazine

KBN135 holds 40 tools as standard and maximum of 120 tools as an option. Fixed address tool selection method and a special controlling panel increase convenience.

(KBN135C : 40 Tool Standard / 60 Tool Option)



☉ Machine Dimensions According to Magazine Selection (KBN135)

40 Tool	60 Tool	90 Tool	120 Tool
6,900 mm (271.7")	7,300 mm (287.4")	8,275 mm (325.8")	9,250 mm (364.2")

TABLE

NC Rotary Table

High ratio worm gear leads to high precision machining and **built-in position encoder** in B-axis enables precise rotation in 90° and 0.001° which is suitable for machining various shapes. Also it has the largest machining area and best load capacity in its class which enables easier work setting.

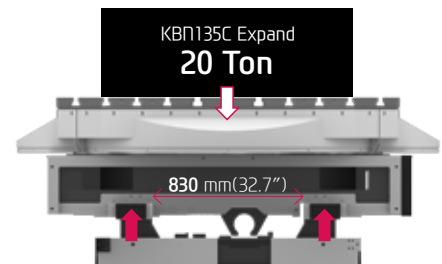

B-AXIS SPUR GEAR

The B-axis is driven by a spur gear to improve productivity, and increase the table positioning speed.

(KBN135C : 2 rpm, KBN135C Expand Option : 1 rpm)

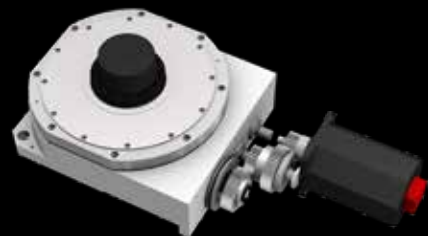

04 USER CONVENIENCE

Various Devices for User Friendly

CHIP DISPOSAL SOLUTION & COOLANT UNIT



Spindle Nozzle & Cutting Air Blow



Gun Coolant



Air Gun



Spindle Cooling Unit

The application of the inverter type, $\pm 0.1^\circ$, enables rapid and effective control of the spindle thermal displacement.



Cabin Screw Chip Conveyor (Standard)

Dual screw type chip conveyors are located at each side of the bed which makes it convenient to remove chips.



Chip Conveyor

Timely and effective disposal of chips will enhance productivity as well as the working environment.

Hinge	Chip Type : Roughing Chip, Long Chip, Chip complex	Material : SS41, 45C, Cast Steel	Left Side Direction
	Highly efficient when disposing a lot of chips. Capable of handling stringy chips..		
Scraper	Chip Type : Finely broken chip blown out	Material : cast Iron, Nonferrous	
	Convenient for shortly cut chips.		
❖ Screw	Chip Type : The lower portion of micro-chips	Material : Steel, Casting	
	Compresses and ejects chips to reduce chip Trouble.		
❖ Drum Filter	Chip Type : Powder, Micro Chip	Material : AL	
	Advantageous in precision, as the chips do not flow in to the coolant nozzle.		

❖ When ordering a screw or drum filter chip conveyor, prior consult with hyundai wia's sales person.

PRECISION & ECO SYSTEM



Linear Scale <Std.>

Linear scales increase positioning accuracy and reduce distortion caused by thermal growth, thus ensuring a more accurate finished part



Rotary Scale <Std.>

Rotary scale on B-axis provide High accuracy positioning and enabling precise machining.



Touch Sensor <Opt.>

Workpiece coordinate values can be set automatically using the optional spindle probe.



TLM (Laser & Touch) <Opt.>

Tool lengths and diameters can be set automatically using the optional tool setter. This can also be used to monitor attrition and detect broken tools.



Oil Skimmer <Std.>

Linear scale helps process highly accurate products through precise positioning.



Economy Lubrication <Std.>

By applying lubricant only when the machines axis are moving lubrication consumption is reduced by compared to standard systems.

Control Panel

Swing type control panel minimizes unnecessary movement of workers and allows optimal control and handling.

Also, movable MPG which is standard adds even more accessibility to workers.



KBN135

KBN135C



05 MACHINING CAPABILITY

The Best Performance, Powerful Cutting CNC Boring Machine

MACHINING AREA

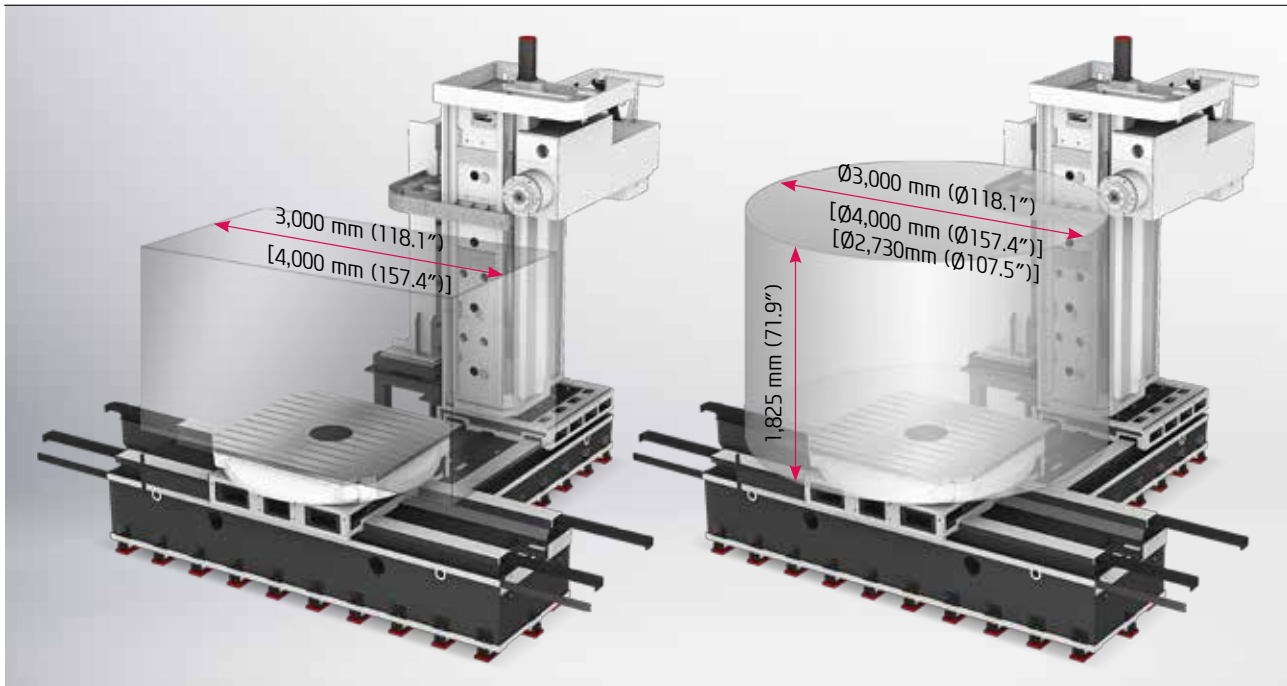

Expansion of Machining Area **OPTION**

KBN135

Unit : mm(in)

ITEM	X-axis	Y-axis	Z-axis	W-axis
Standard	3,000 (118.1")	2,000 (78.7")	1,600 (63")	700 (27.5")
Expansion	4,000 (157.4")	2,500 (98.4")	↑	↑

KBN135C

Unit : mm(in)

ITEM	X-axis	Y-axis	Z-axis	W-axis
Standard	3,000 (118.1")	2,000 (78.7")	1,600 (63")	700 (27.5")
Expansion	4,000 (157.4")	2,500 (98.4")	2,000 (78.7")	↑

Optional Specific Processing Area

Unit : mm(in)

Division	Max. Swing	X-axis Loading Length	Remark
Non Table Around Cover	Ø4,760 (Ø187.4")	4,760 (187.4")	Standard
Standard Table Around Cover	Ø2,940 (Ø115.4")	3,550 (139.8")	Option
Coolant splash cover	Ø2,730 (Ø107.5")	3,550 (139.8")	Option
Expansion Table Around Cover	Ø2,940 (Ø115.4")	4,000 (157.5")	Option

KBN135 / KBN135C

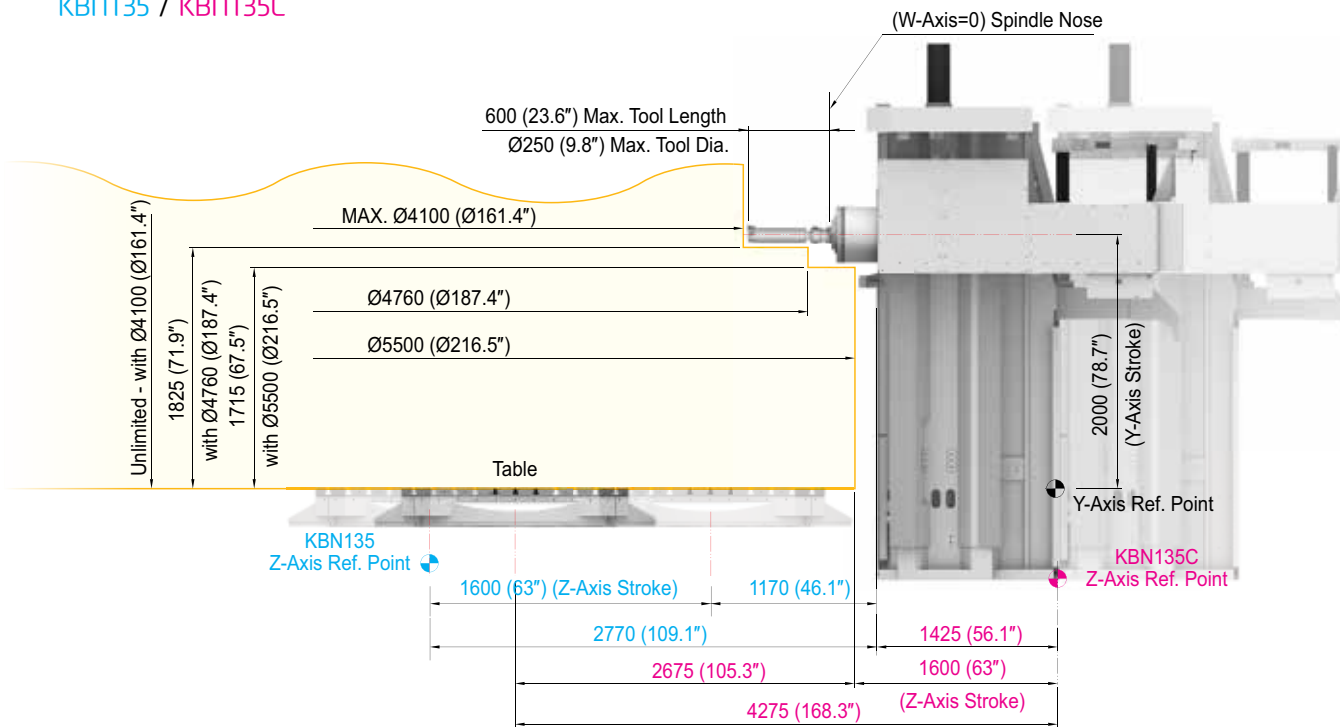

FACE MILLING CAPABILITY

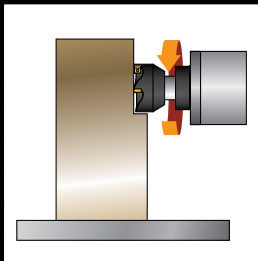

Quill : 0 mm

Speed	450 rpm
Cutting depth	6 mm
Feed	320 mm/min
No. of blades	10 ea
Tool Dia.	160 mm

SS400 (Rolled Structural Steel)

► Excellent Machined Quality

Quill : 300 mm (11.8")

Speed	450 rpm
Cutting depth	5 mm
Feed	320 mm/min
No. of blades	8 ea
Tool Dia.	160 mm

SS400 (Rolled Structural Steel)

► Excellent Machined Quality

❖ The above results might be different by types of processing circumstances.

SPECIFICATIONS

Standard & Optional

Spindle		KBN135	KBN135C
2,000rpm (22kW [30HP])	FANUC	●	-
2,000rpm (26kW [35HP])	FANUC	○	-
2,000rpm (37W [50HP])	FANUC	○	-
2,500rpm (22kW [30HP])	FANUC	-	●
2,500rpm (26kW [35HP])	FANUC	-	●
2,500rpm (37kW [50HP])	FANUC	-	○
2,500rpm (37kW [50HP])	ITROL	-	○
Spindle Cooling System		●	●
W Axis Support Sleeve		○	○
ATC			
ATC Extension	40	●	●
	60	○	○
	90	○	☆
	120	○	☆
Tool Shank Type	BT50	●	●
	CAT50	○	○
Heavy Weight Tool	25kg (55lb)	○	○
U-Center	D'andrea	☆	☆
	45°	●	●
Pull Stud	60°	☆	☆
	90°	☆	☆
Facing Head		○	○
Facing Tool Holder (Facing heads when applying)		○	○
Telescopic Tool Holder (Facing heads when applying)		○	○
Angle Head	500mm(19.7")	○	○
	800mm(31.5")	○	○
Auto Indexing Head	730mm(28.7")	☆	☆
Table & Column			
T-Slot Table		●	●
B Axis Table	0.001°	●	●
X Axis Extension	4,000mm(157.4")	○	○
Y Axis Extension	2,500mm(98.4")	○	○
Z Axis Extension	2,000mm(78.7")	-	○
Index Pin (4x90°)		●	●
Table Auto Clamp Device		●	●
Coolant System			
Coolant Device		○	○
Through Spindle Coolant*	20 bar	○	○
	30 bar	-	-
Gun Coolant (Only for Coolant Device)		○	○
Air Gun		○	○
Cutting Air Blow		○	○
Tool Measuring Air Blow (Only for TLM)		○	○
Coolant Chiller (Only for Coolant Device)		☆	☆
Chip Disposal			
Coolant Tank	400 l (105.7 gal)	-	○
	500 l (132 gal)	○	-
Cabin Screw Chip Conveyor		●	●
Cabin Hinge Chip Conveyor	Left	-	○
Chip Conveyor	Left(Front)	○	-
(Hinge/Scraper)	Left(Rear)	○ (60 Tool : -)	○
-Only for Coolant Device	Left(Left)	○	○
Chip Wagon	Standard (180 l [47.5 gal])	○	○
	Swing (200 l [52.8 gal])	○	○
	Large Swing (290 l [76.6 gal])	○	○
	Large Size (330 l [87.2 gal])	○	○
	Customized	☆	☆
ETC			
Tool Box		●	●
CAD&CAM Software	Need for Munsel No.	☆	☆
Customized Color		☆	☆
W Axis Clamp Device		●	●
Y Axis Clamp Device		●	●

● : Standard ○ : Option ☆ : Prior Consultation - : Non applicable

S/W		KBN135	KBN135C
Machine guidance (HW-MCG)		●	●
Tool Monitoring (HW-TM) : FANUC/ITROL		○	○ / ●
DNC Software (HW-eDNC)		○	○
Spindle Heat Distortion Compensation (HW-TDC)		○	○
Spindle Warm up Function (HW-WARMUP)		●	●
Energy Saving System (HW-ESS)		●	●
Machine Monitoring System (HW-MMS)		○	○
RENISHAW GUI		○	○
Machining Condition Selection (HW-MCS)		●	●
Adaptive Feed Control (HW-AFC)		●	●
Conversational Program (HW-DPRO)		○	○
Safety Device			
Front Full Cover		●	●
Table Around Cover (Only for Thru. Coolant)		○	○
Extension Table Around Cover		☆	☆
Safety Fence		○	○
Electric Device			
Call Light	1 Color : ●	●	●
Call Light & Buzzer	3 Color : ● ■ ■ B	○	○
Work Light		●	●
Electric Cabinet Light		○	○
Remote MPG		●	●
3 Axis MPG		○	○
Work Counter	Digital	○	○
Total Counter	Digital	○	○
Tool Counter	Digital	○	○
Multi Tool Counter	6 EA	○	○
	9 EA	○	○
Electric Circuit Breaker		○	○
AVR (Auto Voltage Regulator)		☆	☆
Transformer	50kVA	○	○
	60kVA	○	○
Auto Power Off		○	○
Back up Module for Black out		○	○
Measuring Device			
Air Zero		○	○
TLM	Touch	○	○
(Marposh/Renishaw/Blum)	Laser	○	○
Tool Broken Detective Device		☆	☆
Linear Scale	X/Y/Z Axis	●	●
Rotary Scale	B Axis	●	●
Coolant Level Sensor		☆	☆
Environment			
Air Conditioner		○	○
Dehumidifier		○	○
Oil Mist Collector		☆	☆
Oil Skimmer (Only for Chip Conveyor)		○	●
ML (Minimal Quantity Lubrication)		☆	☆
Fixture & Automation			
Sub O/P		☆	-
Control of Additional Axis	1Axis	☆	☆
	2Axis	-	-
External M Code 4ea		○	○
I/O Extension (In & Out)	16 Contact	○	○
	32 Contact	○	○
Hyd. Device			
Std. Hyd. Unit	45bar, 200 l (52.8 gal)	●	●
Center Hyd. Supply Device		-	-
Hyd. Unit for Fixture	45bar	☆	☆
	70bar	☆	☆
	100bar	☆	☆
	Customized	☆	☆

Through Spindle Coolant* : Please check the filter types with sales representative.
Specifications are subject to change without notice for improvement.

SPECIFICATIONS

Spindle Output/Torque Diagram

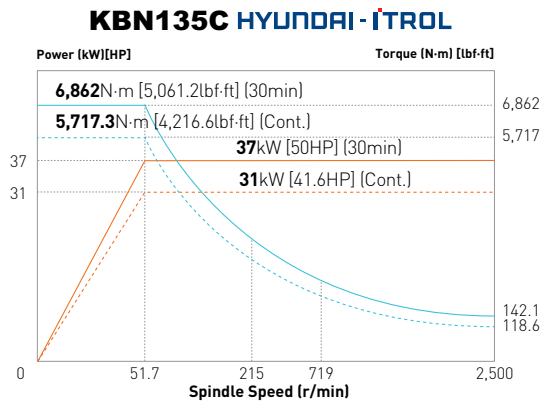
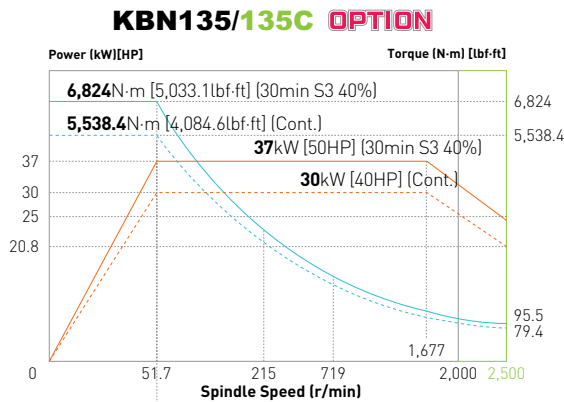
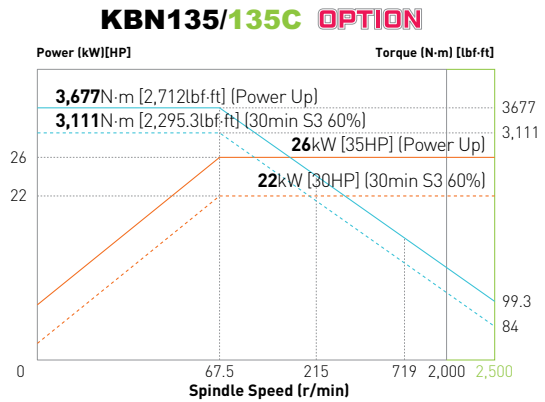
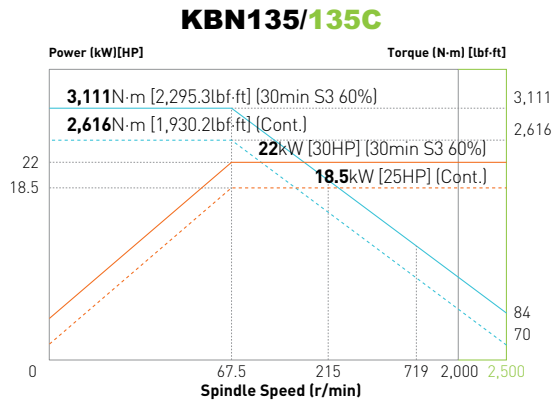

Special Head Specifications

Angle Head	
Length	500 mm (19.7")
Spindle Speed	800 rpm
Speed Ratio	1:1
Lubrication	Grease
Tool Change	Manual
Tool Shank	BT50
Tool Clamping	Bolting (M24)
Max. Tool Weight	20 kg (44.1 lb)
Machine Weight	230 kg (507 lb)

Facing Head	
Radial Transverse	160 mm (6.3")
Max. Rotation	170 rpm
Body Diameter	Ø600 mm (Ø23.6")
ax. Cutting Diameter	Ø920 mm (Ø36.2")
Feed Ratio (Quill:Slide)	1:2
Clamping Bolt	4-M20
T-Slot Distance	190 mm (7.5")
Machine Weight	320 kg (705.5 lb)

SPECIFICATIONS

External Dimensions

unit : mm(in)

KBN135 (Expand Option)

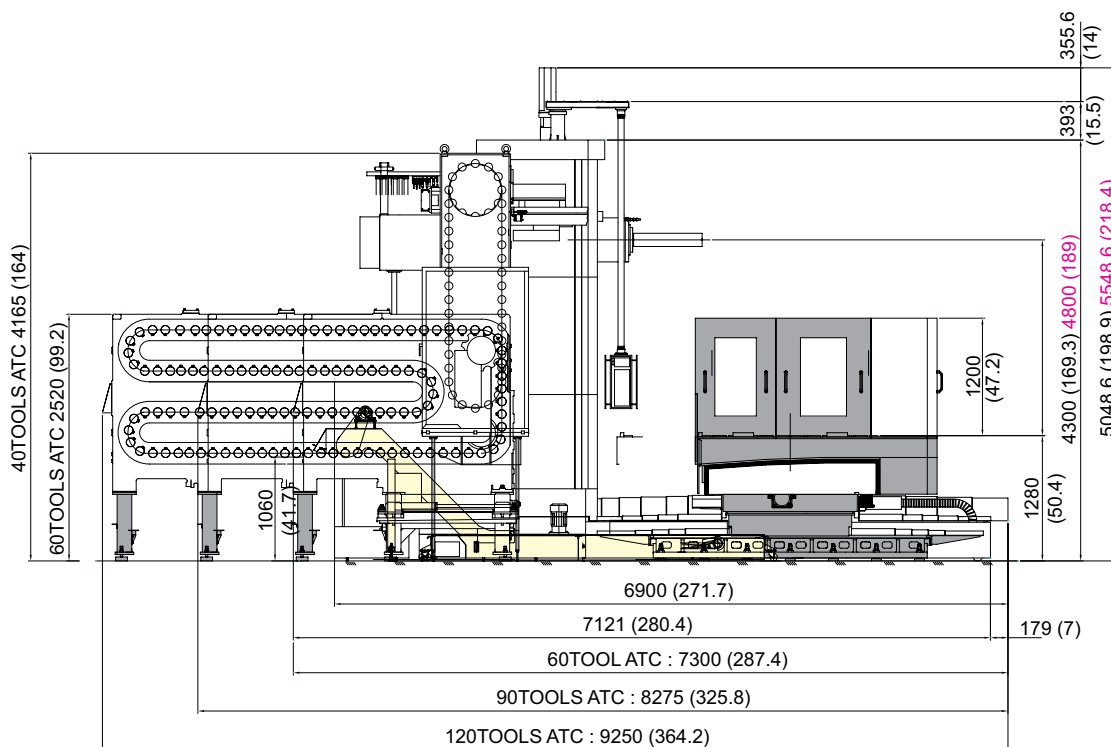
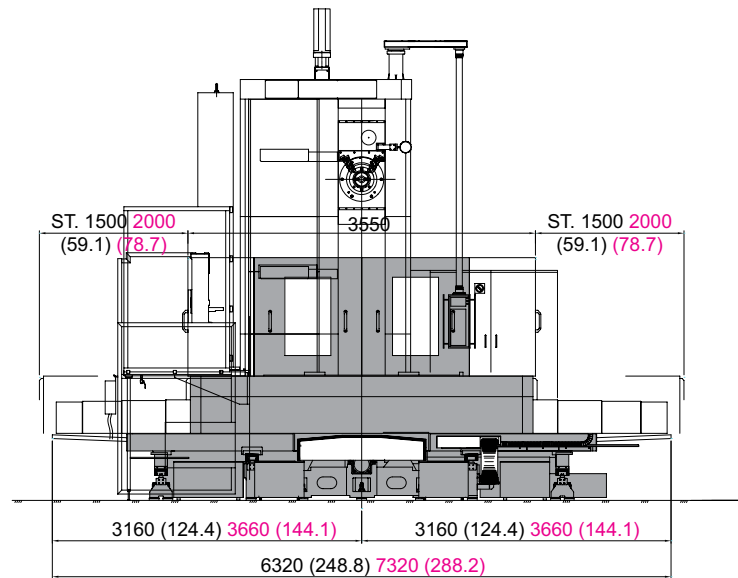

SPECIFICATIONS

External Dimensions

unit : mm(in)

KBN135C (Expand Option)

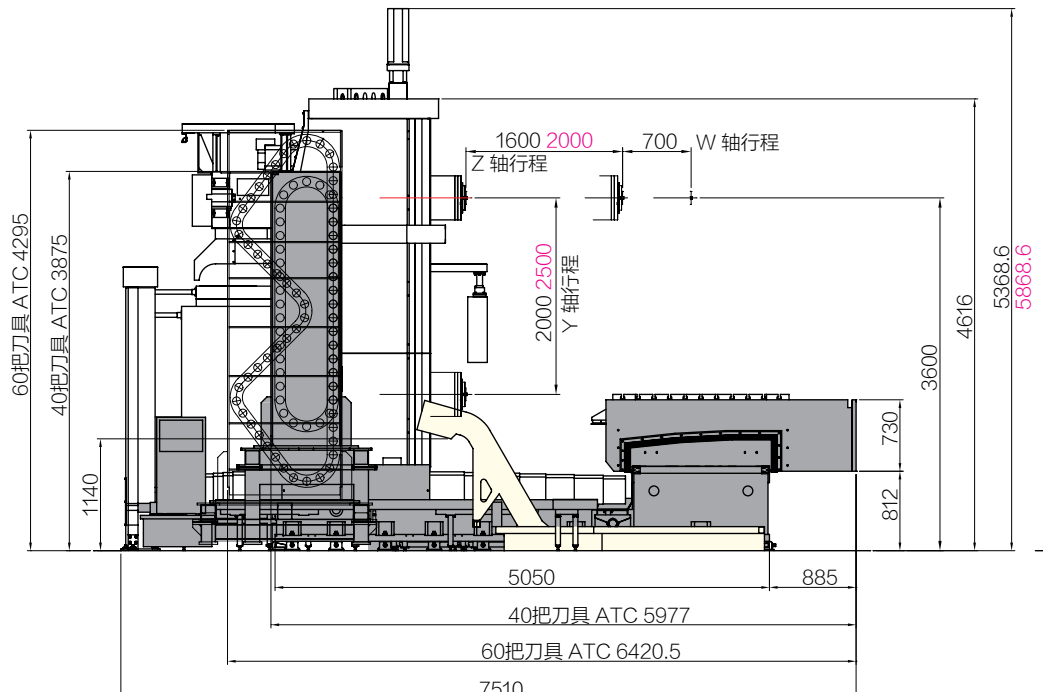
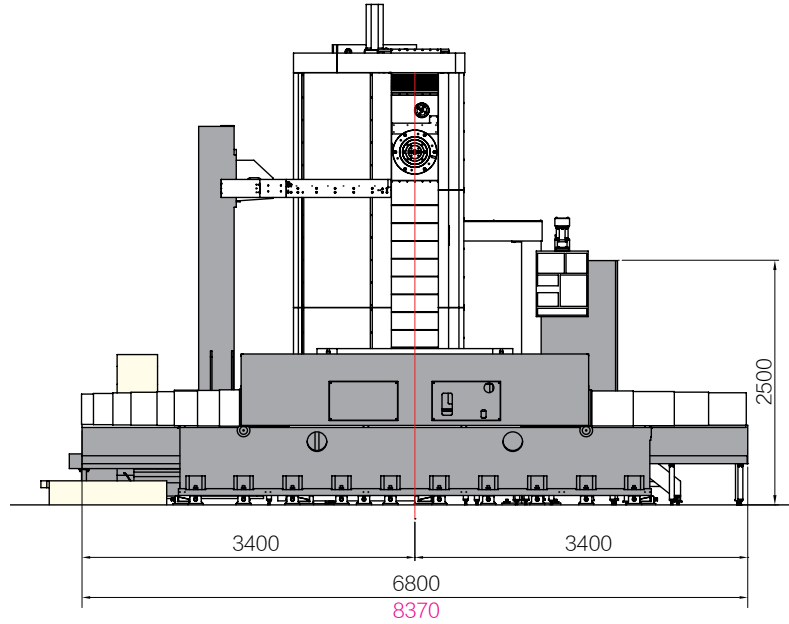

Height when upper hydraulic supply device is attached: 3,845mm (151.4")

SPECIFICATIONS

Splash Guard

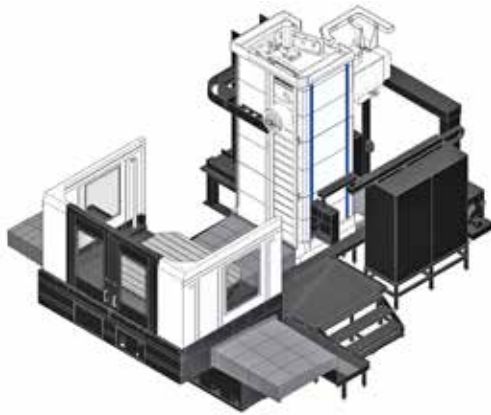

A-Type Table Around Cover

KBN135	○	KBN135C	○
--------	---	---------	---

※ Cannot open or close on KBN135

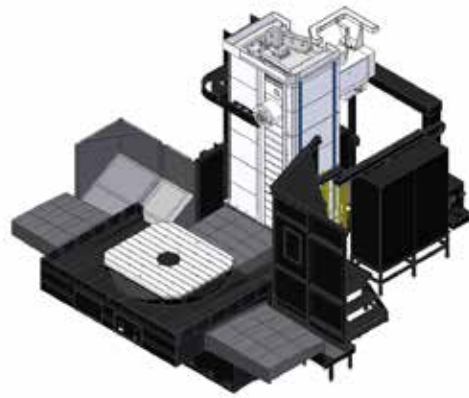

B-Type Coolant Protect Cover

KBN135	-	KBN135C	○
--------	---	---------	---

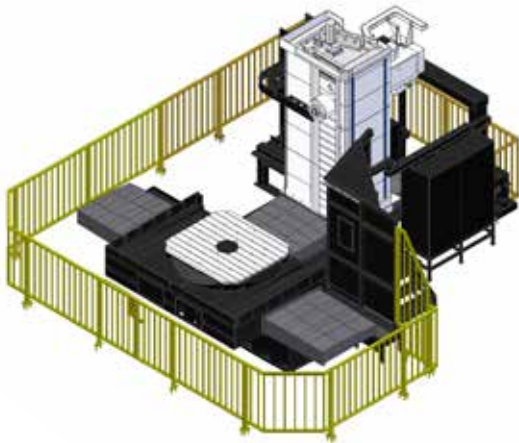

C-Type Safety Fence

KBN135	○	KBN135C	○
--------	---	---------	---

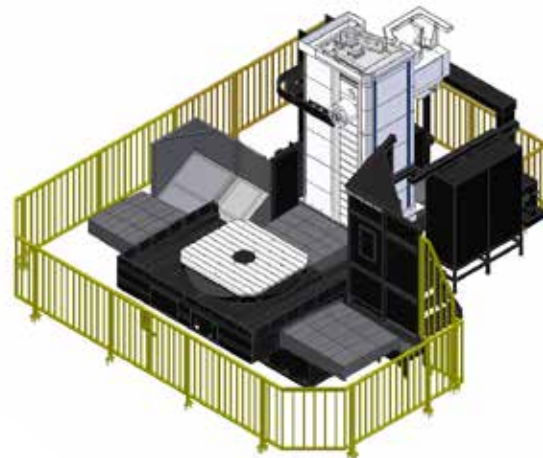

D-Type B+C Type

KBN135	-	KBN135C	○
--------	---	---------	---

SPECIFICATIONS

Table Dimensions

unit : mm(in)

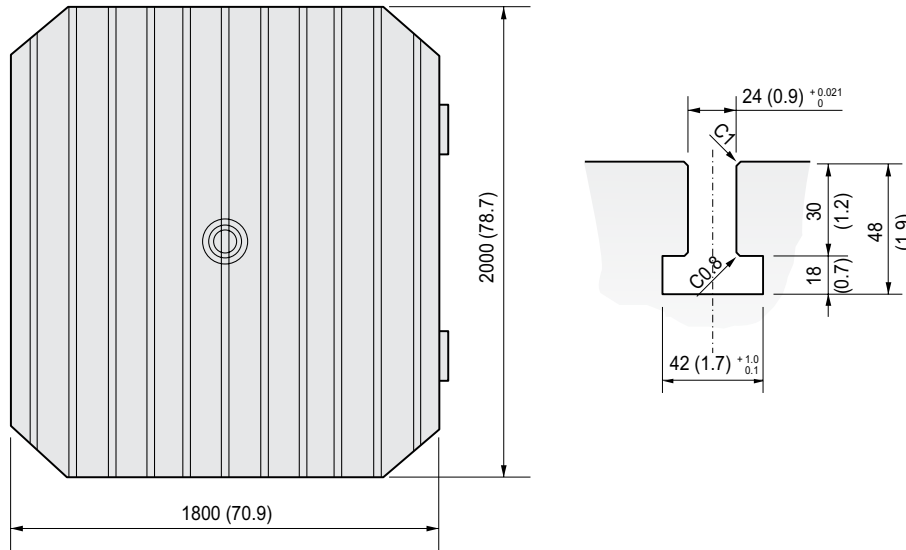

Tool Shank

unit : mm

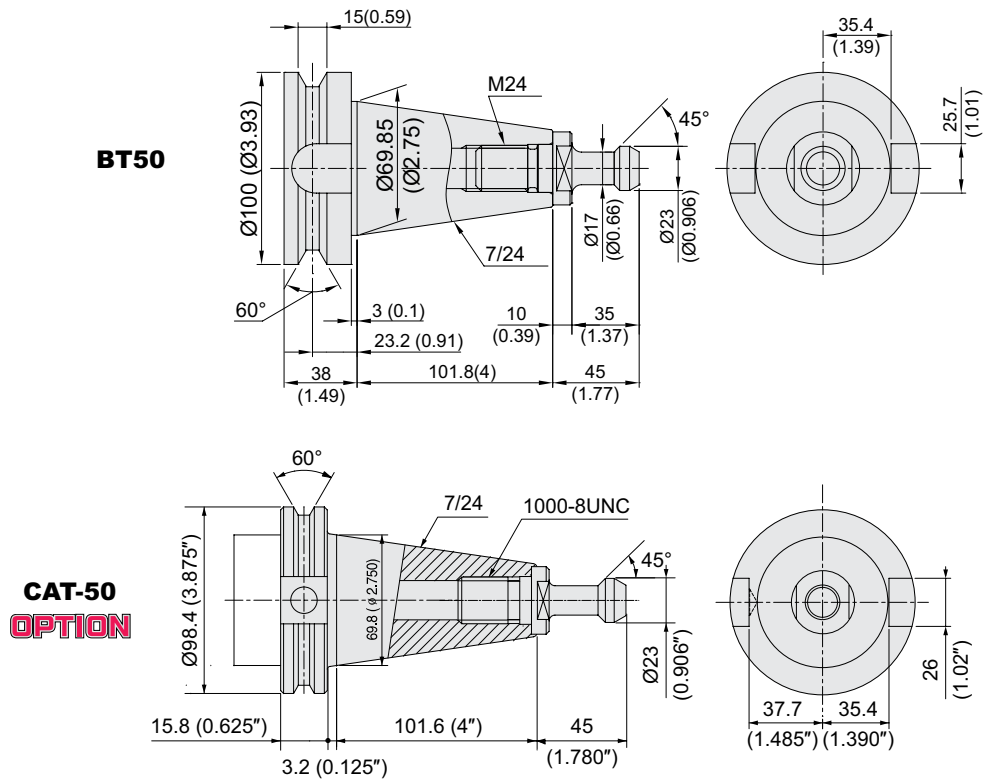

SPECIFICATIONS

Specifications

[] : Option

ITEM			KBN135	KBN135 (Expand Option)	KBN135C	KBN135C (Expand Option)	
TABLE	Table Size	mm(in)	2,000×1,800 (78.7"×70.9")				
	Maximum Load Capacity	kgf(lb)	10,000 (22,046)		❖ 15,000 (33,069) [20,000 (44,092)]	❖ 20,000 (44,092)	
	Min. Indexing Angle	deg	0.001° / 90° (LOCATING PIN)				
SPINDLE	Spindle Quill Diameter	mm	Ø135 (5.3")				
	Spindle Taper	-	NT #50				
	Spindle Speed (rpm)	r/min	2,000 [2,000] [2,000]		2,500 [2,500] [2,500] [2,500]		
	Spindle Power (Max./Cont.)	kw(HP)	22/18.5 (30/25) [26/22 (35/30)] [37/30 (50/40)]		22/18.5 (30/25) [26/22 (35/30)] [37/30 (50/40)] [37/31 (50/41.6)]		
	Spindle Torque(Max./Cont.)	N·m	3,111/2,617 [3,677/3,111] [6,824/5,538] [KBN135C : 6,862/5,717]				
	Spindle Driving Method	-	3 STEP GEAR				
	FEED	Travel	X-axis	mm(in)	3,000 (118.1")	4,000 (157.5")	3,000 (118.1")
Y-axis			mm(in)	2,000 (78.7")	2,500 (98.4")	2,000 (78.7")	2,500 (98.4")
Z-axis			mm(in)	1,600 (63")			2,000 (78.7")
W-axis			mm(in)	700 (27.6")			
Distance from Column to SP. center		mm(in)	0 ~ 2,000(78.7")	0 ~ 2,500(98.4")	0 ~ 2,000(78.7")	0 ~ 2,500(98.4")	
Distance from Table Surface to SP		mm(in)	800 ~ 2,400(31.5"~94.5")				800 ~ 2,800 (31.5"~110.2")
Rapid Traverse Rate (X/Y/Z/W)		m/min(ipm)	8/8/8/8 (315/315/315/315)		10/10/10/8 (394/394/394/315)	7/10/10/8 (276/394/394/315)	
Slide Type		-	BOX GUIDE				
ATC	Number of Tools	EA	40 [60, 90, 120]		40 [60]		
	Tool Shank	-	BT50				
	Max. Tool Dia. (W.T/W.O)	mm(in)	Ø125/Ø250 (4.9"/9.8")				
	Max. Tool Length	mm(in)	600 (23.6")				
	Max. Tool Weight	kg(lb)	20 [30] (44.1 [66.1])				
	Tool Selection Method	-	FIXED ADDRESS				
	Tool Change Time	T-T	sec	30		22.4	30
C-C		sec	70		33.2	70	
TANK CAPACITY	Coolant Tank	ℓ (gal)	500 (132.1)		400 (105.7)		
	Lubricating Tank	ℓ (gal)	8.5 (2.2)				
	Hydraulic Tank	ℓ (gal)	200 (52.8)				
POWER SUPPLY	Air Consumption (0.5MPa)	ℓ /min(gal/min)	250 (66)				
	Electric Power Supply	KVA	42				
	Thickness of Power Cable	Sq	Over 50				
	Voltage	V/Hz	220/60 (200/50*)				
MACHINE	Floor Space (L×W)	mm(in)	6,320×6,900 (248.8"×271.7")	7,320×6,900 (288.2"×271.7")	6,880×7,510 (270.9"×295.7")	8,370×7,910 (329.5"×311.4")	
	Height	mm(in)	5,049 (198.9")	5,549 (218.4")	5,369 (211.4")	5,869 (231")	
	Weight	kg(lb)	37,200 (82,012)	44,000 (97,003)	46,500 (102,515)	52,000 (114,640)	
NC	Controller	-	FANUC 31i-B		FANUC 31i-B [HYUNDAI-iTROL]		

❖ within 300mm(11.8") of the biased weight

*) Using 50Hz voltage instead of 60Hz may lower the output of motors. (excluding servo motors and inverter motors)

Specifications are subject to change without notice for improvement.

CONTROLLER

FANUC 31i-B

☆ Needed technical consultation

Controlled axis / Display / Accuracy compensation	
Control axes	5 axes (X, Y, Z, W, B)
Simultaneously controlled axes	4 axes
Least setting Unit	X, Y, Z axes : 0.001 mm (0.0001 inch)
	B axes : 0.001 deg
Least input increment	X, Y, Z axes : 0.001 mm (0.0001 inch)
	B axes : 0.001 deg
Inch / Metric conversion	G20 / G21
High response vector control	
Interlock	All axes / Each axis
Machine lock	All axes
Backlash compensation	± 0 ~ 9999 pulses (Rapid traverse / Cutting feed)
Position switch	
LCD / MDI	10.4 inch color LCD
Feedback	Absolute motor feedback
Stored stroke check 1	Over travel
Stored pitch error compensation	
Operation	
Automatic operation (Memory)	
MDI operation	
DNC operation	Needed DNC software / CF card
Program restart	
Wrong operation prevention	
Program check function	Dry run, Program check Z axes Machine lock, Stroke check before move
Single block	
Search function	Program Number / Sequence Number
Interpolation functions	
Pano interpolation	
Positioning	G00
Linear interpolation	G01
Cylindrical interpolation	G02, G03
Exact stop mode	Single : G09, Continuous : G61
Dwell	G04, 0 ~ 9999.9999 sec
Skip	G31
Reference position return	1st reference : G28
	2nd reference : G27
	Ref. position check : G30
Thread synchronous cutting	G33
Helical interpolation	Circular + Linear interpolation 2 axes(max.)
Feed function / Acc. & Dec. control	
Manual feed	Rapid traverse
	Jog : 0~5,000mm/min (197 ipm)
	Manual handle : x1, x10, x100 pulses
	Reference position return
Cutting feed command	Direct input F code
Feedrate override	0 ~ 200% (10% Unit)
Rapid traverse override	F0% (F1%), F25%, F50%, F100%
Override cancel	
Feed per minute	G94
Feed per revolution	G95
Look-ahead block	40 Block
	200 Block (Mold)
Program input	
Tape Code	EIA / ISO
Optional block skip	1 ea
Absolute / Incremental program	G90 / G91
Program stop / end	M00, M01 / M02, M30
Maximum command unit	± 999,999.999 mm (± 99,999.9999 inch)
Plane selection	X-Y : G17 / Z-X : G18 / Y-Z : G19
Workpiece coordinate system	G52, G53, 48 pairs (G54.1 P1 ~ 48)
Manual absolute	Fixed ON
Programmable data input	G10
Sub program call	10 folds nested
Custom macro	#100 ~ #149, #500 ~ #549
G code system	A
Programmable mirror image	G51.1, G50.1
G code preventing buffering	G4.1
Including Chamfering / Corner R	
Canned cycle	G73, G74, G76, G80 ~ G89
Coordinate rotation	G68, G69

Auxiliary function / Spindle speed function	
Auxiliary function	M 4 digit
Level-up M Code	Multi / Bypass M code
Spindle speed command	S 5 digit , Binary output
Spindle override	0% ~ 150% (10% Unit)
Spindle orientation	M19
FSSB high speed rigid tapping	
Tool function / Tool compensation	
Tool function	Max. T 8 digit
Tool life management	256 pairs ☆
Tool offset pairs	99 pairs
Tool nose radius compensation	G40, G41, G42
Tool nose length compensation	G43, G44, G49
Tool offset memory C	Tool length, diameter, abrasion(length, diameter)
Tool length measurement	Z axes Input C
Editing function	
Part program storage size	640m (256KB)
No. of registerable programs	1000 EA
Program protect	
Background editing	
Extended part program editing	Copy, move and change of NC program
Memory card program edit	
Data input / output & Interface	
I/O interface	RS 232C serial port, CF card, USB memory Embedded Ethernet interface
Screen hard copy	
External message	
External key input	
External workpiece number search	
Automatic data backup	
Setting, display and diagnosis	
Self-diagnosis function	
History display	Alarm & Operator message & Operation
Run hour / Parts count display	
Maintenance information	
Actual cutting feedrate display	
Display of spindle speed / T code	
Graphic display	
Operating monitor screen	Spindle / Servo load etc.
Power consumption monitoring	Spindle & Servo
Spindle / Servo setting screen	
Multi language display	Support 20 languages
Display language switching	Selection of 5 optional Languages
LCD Screen Saver	Screen saver
Processing select	Speed/rigidity setting
Option	
Additional optional block skip	9 ea ☆
Fast ethernet	Needed option board
Data server	Needed option board
Protection of data at 8 levels	
Sub Spindle control	
Polar coordinate command	G15, G16
Polar coordinate interpolation	G12.1, G13.1
Cylindrical interpolation	G07.1
One-way positioning	G60
Stored stroke check 2, 3	
Inverse-time feed	G93
Scaling	G50, G51
Manual guide i	Conversational auto program
Handle interrupt	
Manual handle feed	2/3 units
Additional custom macro variables	#100~#199, #500~#999
	#100~#199, #500~#999, #98000~#98499
Retraction for rigid tapping	
Tool management function	
Tool offset number	Max. 2000 pair ☆
Program storage capacity	512KB ~ 8MB ☆
Program registration number	Max. 4000 ea ☆
Additional work coordinate	Max. 300 pair (G54.1 P1 ~ P300)
AICC II	200 block
	400 / 600 / 1000 block ☆

Figures in inch are converted from metric values.

The FANUC controller specifications are subject to change based on the policy of company CNC supplying.

CONTROLLER

HYUNDAI-iTROL (KBN135C)

Control & Composition	
Number of axis/Spindles	3 axis (X, Y, Z)
Number of axis/Spindles, max.	6 axis (Axis + Spindle)
Color display	TFT 10.4" Color (800 x 600)
Keyboard	QWERTY Full Keyboard
Part program	1MB, 3MB, 5MB
Addition of part program on CF card	
Transfer Function	
Feedrate override	0% ~ 200%
Transfer value input range	± 999999999
Unlimited rotation of rotation axis	
Acc./Dec. with jerk limitation	
Measuring systems 1 and 2, selectable	
Travel to fixed stop	
Auto servo drive tuning	
Spindle Function	
Spindle override	0% ~ 150%
Spindle speed, max. programmable value ange	1000000 ~ 0.0001
Automatic gear stage selection	
Spindle orientation	
Spindle speed limitation	
Rigid tapping	
Interpolation	
Linear interpolation axis, max.	4 axis
Circle via center point and end point	
Circle via interpolation point	
Helical interpolation	
Non-uniform rational B splines	
Compressor for 3-axis machining	
Advanced surface	
Program Function	
Subroutine levels, max.	11
Interrupt routines, max.	4
Number of levels for skip blocks	2
Polar Coordinates	
Dimensions inch/metric, changeover manually or via program	
Dynamic preprocessing memory FIFO	
Look ahead	50, 100, 150
Absolute/Incremental command	G90 / G91
Scaling/Rotation	
Read/Write system variables	
Block search	
Edit background	
Processing program number, max.	750
Using of CF Card, USB	
Basic coordinate number, max.	1
Work coordinate number, max.	100
Basic/Work coordinate programming change	
Scratching function	
Global and Local user data (GUD/LUD)	
Global program user data	
Interactive cycle program	
Tool Function	
Tool radius compensations	
Tool offset selection via T/D numbers	
Tools / Cutting edges in tool list	80/160, 128/256, 256/512
Monitoring Function	
Working area limit	
Software and Hardware limit	
Zero-speed/Clamping monitoring	
2D/3D protection zones	
Contour monitoring	

Compensation	
Backlash compensation	
Leadscrew error compensation	
Measuring system error compensation	
Feedforward control (Speed control)	
Safety Function	
Safe torque off (STO)	
Safe brake control (SBC)	
Safe stop 1 (SS1)	
Diagnostic Function	
Alarm/Message , Alarm log	
PLC status/LAD online display	
PLC remote connection (Ethernet)	
Automation Support Function	
Actual velocity display	
Tool life management	As time / As amount
Work counter/Cycle time	Embedded
2D simulation	
Manual Operation	
Manual handle/Log transfer	
Manual measurement of workpiece / tool offset	
Automatic tool/Workpiece measurement	
Automatic/Program reference approach	
Automatic Operation	
Program run as using CF card/USB	
Program control/modification	
Block search	
Reposition	
Preset (Set actual value)	
Data Transmission	
Ethernet network	
USB memory stick & CF card	
Convenience Function	
Processing setting	Coordinate setting, Auto tool length measurement
Processing support	Tool Monitoring, Spindle overload monitoring
Maintenance	Turret Guidance, I/O monitoring, Manual
Maintenance / Management	Soft MCP, Spindle warming-up M/G code list
SMART machining	
Energy saving function (ECO)	
Machine Monitoring System (MMS Lite)	
Language	
Standard support language	Chinese Simplified, English, Korean

Option	
Maximum skip block number	10
DRF offset	
MDI program save/load	
Teach-In mode	
3D simulation	Except for working area/Collision check
Real time simulation	
Shop Mill	Conversational Program
Spline interpolation	
Program remote control in network	
Language	Chinese Traditional, French, German, Italian, Portuguese, Spanish

HW-MMS

HYUNDAI WIA Machine Monitoring System



A brand new manufacturing machine by Hyundai Wia, HW-MMS is a unique software capable of monitoring the operation status of manufacturing machines in factories, a smart solution to improve manufacturing conditions of customers.

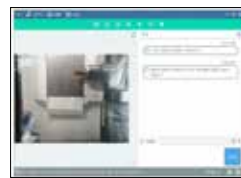
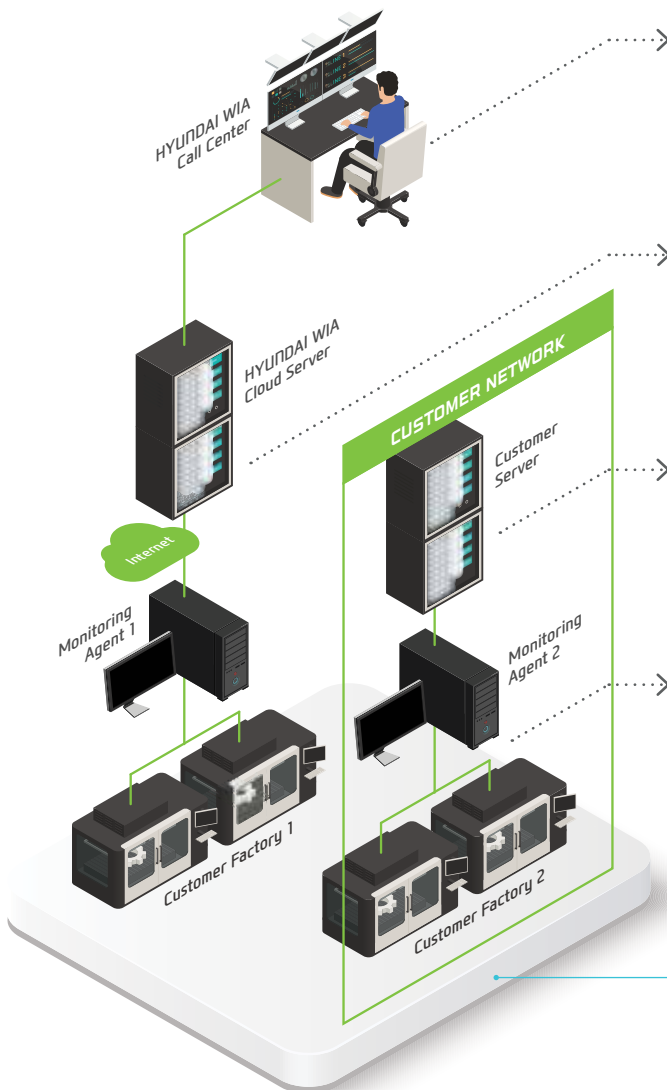

HW-MMS Remote

Hyundai Wia Call Center's remote diagnosis service provides a HMI/video diagnostic function.



HW-MMS Cloud

A cloud server-based equipment monitoring system for collecting and analyzing facility operation data.



HW-MMS Edge

A client server-based tool monitoring system for collection/analysis of facility operation data. (Compatible with client MES / ERP interface)



HW-MMS PT

This is a facility big data-based smart factory solution that collects and analyzes changes in spindle/feed data and NC processing files

HYUNDAI WIA
Smart Factory Solution



KBN135
Movie



KBN135C
Movie



You Tube HYUNDAI WIA MT

www.youtube.com/HYUNDAIWIAMT

EXPERIENCE THE NEW TECHNOLOGY

With its top-quality HYUNDAI WIA machine tool creates a new and better world.



<http://machine.hyundai-wia.com>

HYUNDAI WIA Machine Tools
Global Links

HEADQUARTER

Changwon Technical Center/R&D Center/Factory 153, Jeongdong-ro, Seongsan-gu, Changwon-si, Gyeongsangnam-do, Korea TEL : +82 55 280 9114 FAX : +82 55 282 9114

Overseas Sales Team /R&D Center 37, Cheoldobangmulgwan-ro, Uiwang-si, Gyeonggi-do, Korea TEL : +82 31 8090 2539

OVERSEAS OFFICES

HYUNDAI WIA Machine America corp. 450 Commerce Blvd, Carlstadt, NJ 07072, USA TEL : +1-201-987-7298

HYUNDAI WIA Europe GmbH Alexander-Fleming-Ring 57, 65428 Rüsselsheim Germany TEL : +49-0-6142-9256-0

HYUNDAI WIA Machine Tools China 2-3F, Bldg6, No.1535 Hongmei Road, Xuhui District, Shanghai, China TEL : +86-21-6427-9885

India Branch Office #4/169, 1st Floor, LOTTE BLDG, Rajiv Gandhi Salai, (OMR), Kandanchavadi, Chennai - 600096, Tamilnadu, India TEL : +91-76-0490-3348

Vietnam Branch Office Flat number 05, Service and Trade Center of Viet Huong Industrial Zone, Highway 13, Thuan Giao, Thuan An, Binh Duong, Vietnam TEL : +84-3-5399-5099